



Owner's Manual
ZAFIRA
Operation, Safety and Maintenance



Data specific to your vehicle

Please enter your vehicle's data here to keep it easily accessible. This information is available under the section "Technical data" as well as on the identification plate and in the Service Booklet.

Fuel

Designation

Engine oil

Grade

Viscosity

Tyre pressure

Summer tyres

Winter tyres

Tyre size

with up to 3 people

with full load

Front Rear

Front Rear

Front Rear

Front Rear

Weights

Permissible Gross Vehicle Weight

- EC kerbweight

= Loading

Your Zafira

is an intelligent combination of forward-looking technology, impressive safety, environmental friendliness and economy.

It now lies with you to drive your vehicle safely and ensure that it performs perfectly. This Owner's Manual provides you with all the necessary information to that end.

Make sure your passengers are aware of the possible risk of accident and injury which may result from improper use of the vehicle.

You must always comply with the specific laws of the country that you are travelling through. These laws may differ from the information in this Owner's Manual.

When this Manual refers to a workshop visit, we recommend your Vauxhall Authorised Repairer.

All Vauxhall Authorised Repairers provide first-class service at reasonable prices.

You will receive quick, reliable and individual service.

Experienced mechanics, trained by Vauxhall, work according to specific Vauxhall instructions.

The Owner's Manual should always be kept in the vehicle: Ready to hand in the glove compartment.

Make use of the Owner's Manual:

- The "In Brief" section will give you an initial overview.
- The table of contents at the beginning of the owner's manual and within the individual chapters will show you where everything is.
- Its index will help you find what you want.
- It will familiarize you with the sophisticated technology.
- It will increase your pleasure in your vehicle.
- It will help you to handle your vehicle expertly.

The Owner's Manual is designed to be clearly laid-out and easily understood.

This symbol signifies:

► continue reading on next page.

❖ The asterisk signifies equipment not fitted to all vehicles (model variants, engine options, models specific to one country, optional equipment, Genuine Vauxhall Parts and Accessories).

Warning

Text marked  **Warning** provides information on risk of accident or injury. Disregard of the instructions may lead to injuries or endanger life. Inform your passengers accordingly.

Yellow arrows in the illustrations serve as points of reference or indicate some action to be performed.

Black arrows in the illustrations indicate a reaction or a second action to be performed.

Directional data, e.g. left or right, or front or back, in the descriptions always relate to the direction of travel.

We wish you many hours of pleasurable driving

Your Vauxhall Team

Contents

Commitment to customer satisfaction:

Our aim: to keep you happy with your vehicle. All Vauxhall Authorised Repairers offer first-class service at competitive prices. Experienced, factory-trained technicians work according to factory instructions. Your Authorised Repairer can supply you with GENUINE VAUXHALL-APPROVED PARTS, which have undergone stringent quality and precision checks, and of course useful and attractive VAUXHALL-APPROVED ACCESSORIES.

Our name is your guarantee!

For details of the

Vauxhall Authorised Repairer Network, please ring this number; 0845 090 2044

In Brief	2
Locks, Doors, Windows	30
Seats, Interior	49
Instruments, Controls	82
Lighting	105
Infotainment System	112
Climate Control	114
Driving and Operation	131
Self-help, Vehicle Care	170
Service, Maintenance	198
Technical Data	210
Index	230

In Brief



16968 T

**To unlock and open the vehicle:
Press button , pull door handle**

- ▶ Door locks – page 30,
- Keys – page 30,
- Electronic immobiliser – page 30,
- Radio frequency remote control – page 32,
- Central locking system – page 37,
- Anti-theft locking system * – page 38,
- Vauxhall alarm system * – page 42.



S 1151B

**Unlock vehicle and open with
the Open&Start system *:
Electronic key in vehicle
reception range,
Pull handle**

- ▶ Open&Start system * – page 33.

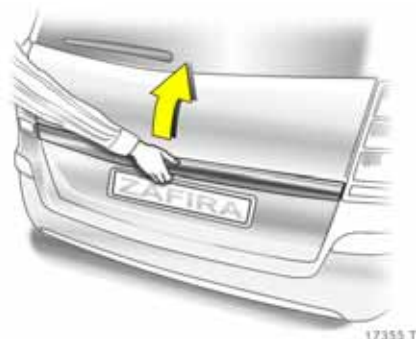

Unlock luggage compartment and open:
Press button \geq on the remote control, or for the Open&Start system \ast place electronic key in the vehicle reception range, operate button beneath handle

► Open&Start system \ast – page 33,
 Radio frequency remote control – page 32,
 Central locking system – page 37,
 Vauxhall alarm system \ast – page 42.



To adjust front seat:
Pull handle, slide seat, release handle

► Seats – page 49,
 Seat position – page 50.

⚠ Warning

Important: Do not sit nearer than 10 inches (25 cm) from the steering wheel, to permit safe airbag deployment.



Adjust front seat backrests:
Turn handwheel

Move seat backrest to suit seating position.

Do not lean on seat when adjusting.

► Seats – page 49,
 Seat position – page 50,
 Folding down the front passenger's seat – page 57.



S 11512

**Adjusting front seat height *:
Operate lever on outboard side
of seats**

Lever pumping motion
up: Seat higher
down: Seat lower

► Seats – page 49,
Seat position – page 50.



S 11513

**To adjust front seat
inclination *:
Pull inner lever on front of seat,
adjust inclination, release lever,
engage seat in position**

Adjust inclination by shifting body weight.

► Seats – page 49,
Seat position – page 50.

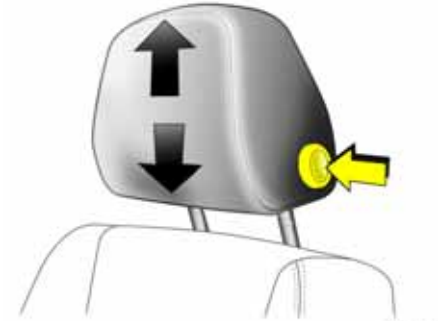

16976 T

**Adjusting height of head
restraints of front seat and
outboard seats in second row:
Press knob to release, adjust
height, engage**

► Head restraints – page 51,
Adjust rear centre head restraint and third
seat row head restraints – page 51,
Head restraint position – page 51,
Removing the head restraint – page 52.



**Putting on seat belt:
Pull out the seat belt smoothly,
pass it over your shoulder and
click into the belt buckle**

The seat belt must not be twisted at any point. The lap belt must lie snugly against the body. The front seat backrests must not be tilted back too far (recommended maximum tilting angle approx. 25°).

To release belt, press red button on belt buckle.

- ▶ Three-point seat belt – page 63,
- Airbag system – page 69,
- Seat position – page 50.



**Adjusting interior mirror:
Swivel mirror housing**

Swivel lever on underside of mirror housing to reduce dazzle at night.

- ▶ Mirrors – page 46, automatically dipping interior mirror – page 46.



**Electrical exterior mirrors*,
adjust:
Four-way switch in driver's door**





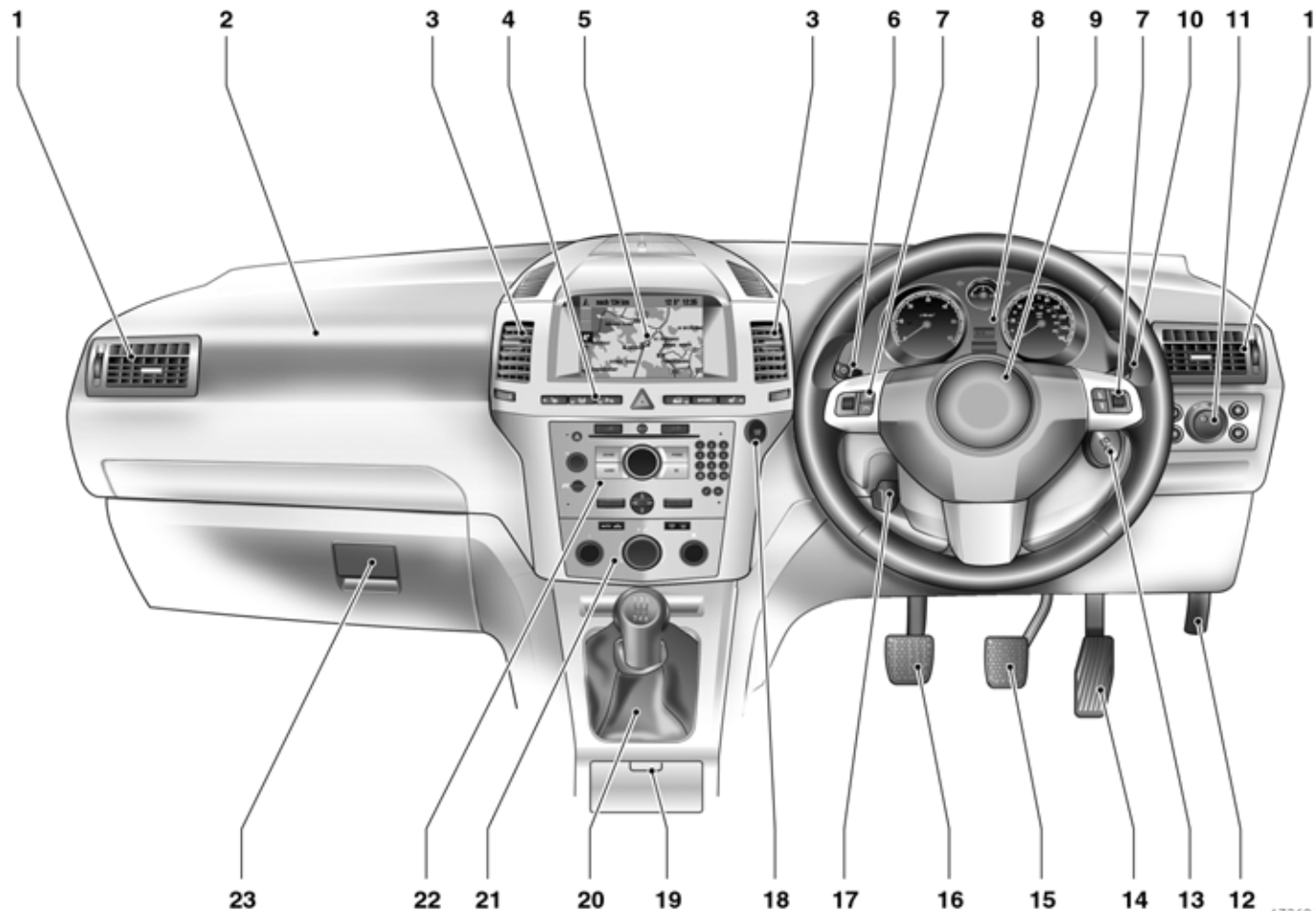























Push right or left mirror switch: four-way switch adjusts relevant mirror.

- ▶ Mirrors – page 45,
- Aspherical exterior mirror – page 45,
- Fold exterior mirror – page 45,
- Heated exterior mirrors – pages 13, 116.



	Page		Page		Page
1	115	7	112	14	141, 143
2	69	8	82	15	141, 157
3	115	9	11	16	141
4	116	10	69	17	9
	154		11, 12, 102	18	17, 33
	155		105	19	79
	152		109	20	14
	11		107		14
	39		106		14, 15
	150		107	21	114
	116		170	22	112
5	101	12	9	23	80, 117
	93, 98		17		
	125				
6	10, 105				
	108				
	109				
	151				

Control indicators

-  **OpenStart system ***,
fault,
see pages 35, 83.
-  **Engine oil pressure**,
see page 83.
-  **Brake system, clutch system ***,
see pages 84, 158, 205.
-  **Airbag systems,
belt tensioners**,
see pages 64, 73, 84.
-  **Electronic Stability Programme
(ESP^{Plus}) ***,
see pages 84, 148.
-  **Seat belt ***,
see pages 63, 84.
-  **Door open**,
see page 84.
-  **Alternator**,
see page 84.
-  **Coolant temperature**,
see pages 84, 204.
-  **Engine electronics,
transmission electronics *,
immobiliser,
diesel fuel filter ***,
fault,
see pages 30, 85, 135, 140, 147.
-  **Easytronic *, start engine**,
see pages 85, 131.
- IDS+** **Interactive Dynamic Driving
System *, Continuous Damping
Control (CDC) *, SPORT
mode ***,
see pages 85, 150.
-  **Engine oil level ***,
see pages 85, 202.
-  **Exterior lights**,
see pages 85, 105.
-  **Parking distance sensors ***,
see pages 85, 152.
-  **Turn signal lights**,
see pages 10, 85, 106.
-  **Fuel level**,
see pages 86, 88, 144.
-  **Front fog lights ***,
see pages 86, 106.
-  **Main beam**,
see pages 10, 86, 105.
-  **Fog tail light**,
see pages 86, 107.
-  **Winter programme of
automatic transmission * or
Easytronic ***,
see pages 86, 133, 139.
-  **SPORT mode of automatic
transmission * or Easytronic ***,
see pages 86, 133, 138.
-  **Seat occupancy recognition ***,
see pages 74, 86.
-  **Exhaust emission ***,
see pages 86, 147.
-  **Anti-lock Brake System (ABS)**,
see pages 86, 159.
-  **Preheating system *,
Diesel particle filter ***,
see page 86.
-  **Deflation Detection System *,
Tyre Pressure Monitoring
System ***,
see pages 87, 154, 155.
-  **Adaptive Forward Lighting
(AFL) ***,
fault,
see pages 87, 108.
-  **Cruise control ***,
see pages 87, 151.

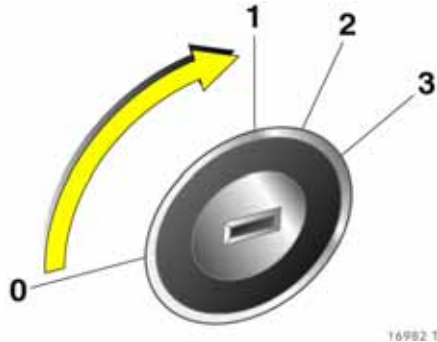

Steering column lock and ignition:

Turn key to position 1.

To release lock, rotate steering wheel a little

Positions:

- 0 = Ignition off,
- 1 = Steering released, ignition off
- 2 = Ignition on,
Diesel engines: preheating
- 3 = Starting

► Start – page 16,
Electronic immobiliser – page 30,
Parking the vehicle – page 18.

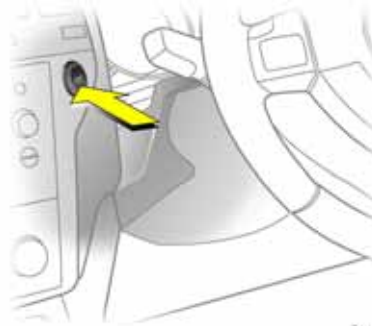

Steering column lock and ignition on vehicles with

Open&Start system *:

Ensure electronic key is in the vehicle interior reception area and press the Start/Stop button
Release steering column lock by moving steering wheel slightly

Release steering column lock by moving steering wheel slightly

To start the vehicle, also operate brake or clutch pedal.

To lock the steering wheel, switch ignition off by pressing the Start/Stop button, open driver's door and engage steering wheel. Do not allow vehicle to move whilst doing this.

► Start – page 17,
Electronic immobiliser – page 30,
Parking the vehicle – page 18.

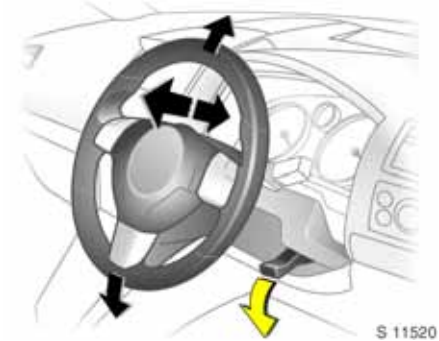

Steering wheel adjustment:

Swivel lever down, adjust height and distance, swivel lever up, engage

Do not adjust steering wheel unless vehicle is stationary and steering column lock has been released.

► Air bag system – page 69.



16986 T

Turn light switch:

- 0** = Off
- P** = Parking lights
- D** = Dipped beam or main beam
- AUTO** = Automatic dipped beam activation *

Press button:

- Fog light icon** = Front fog lights *
- Tail light icon** = Fog tail light

► Lighting – page 105,
Headlight control indicator – page 18.

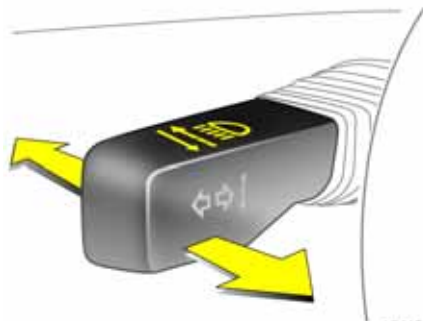

16445 T

Headlight flash, main beam and dipped beam:

- Headlight flash** = Pull stalk towards steering wheel
- Main beam** = Stalk forwards
- Dipped beam** = Stalk forwards again or to the steering wheel

► Dipped beam, headlight flash – page 105.

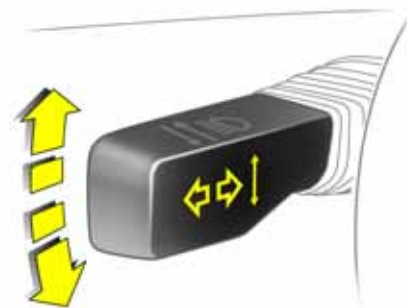

16989 T

Switch on turn signals:

- To the right** = Stalk up
- To the left** = Stalk down

► Turn signals – page 106.



Hazard warning lights:

On = Press ▲

Off = Press ▲ again

► Hazard warning lights – page 107.



Activate horn:

► Press in centre of steering wheel

► Airbag system – page 69,
Remote control on the steering wheel * –
page 112.

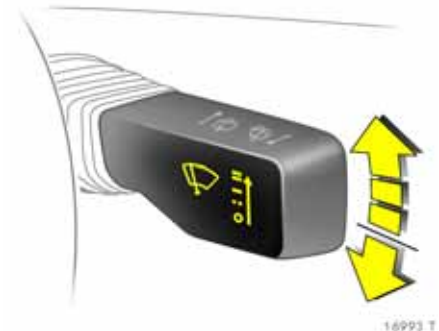

Windscreen wiper:

Move stalk up gently

○ = Off

-- = timed interval wipe

— = Slow

≡ = Fast

Press stalk down from position ○:
Single swipe.

► Windscreen wiper – page 102,
Adjustable wipe interval * – page 103,
Further information – pages 197, 206.



16995 T

Automatic wiping with rain sensor*:

Move stalk up gently

-- = **Automatic wiping with rain sensor**

○ = **Off**

▶ Windscreen wiper – page 102,
Further information – pages 197, 206.



16996 T

Operating windscreen and headlight wash systems*:

Pull stalk towards steering wheel

▶ Windscreen wash system and headlight wash system – page 103,
Further information – pages 197, 207.

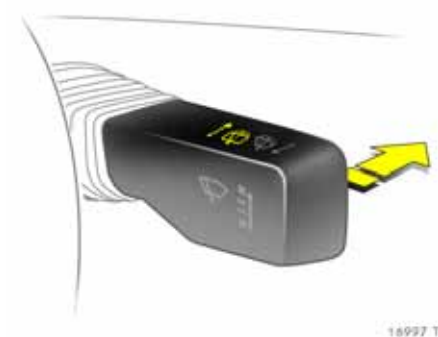

16997 T

Activate rear window wiper and wash system:

Wiper on = Stalk forwards
Wiper off = Stalk forwards again

Washing = Push the stalk forwards and then hold

▶ Rear window wiper and wash system – page 104,
Further information – pages 197, 206.



**Heated rear window,
heated exterior mirrors:**

On = Press 

Off = Press  **again**

► Climate control – page 114,
heated rear window – page 116.



Clearing fogged or icy windows:

Air distribution on 

**Rotary knob for temperature
and air volume to the right;**

Air conditioning system 

Button  **must also be pushed;**

**Automatic air conditioning
system** 

Press buttons  **and** 

**Move rotary knob for
temperature to the right,
air quantity to A;**

**Electronic Climate Control
(ECC)** 

Press button 

► Electronic Climate Control (ECC)  –
page 114.



**Set automatic mode of
Electronic Climate Control
(ECC) **

Press AUTO  **button,
select temperature with rotary
knob,
open air vents**

► Electronic Climate Control (ECC)  –
see page 125.



S 11521

Manual transmission:

Reverse: with the vehicle stationary, wait 3 seconds after declutching and then pull up the button on the selector lever and engage the gear.

If the gear does not engage, set the lever in neutral, release the clutch pedal and depress again; then repeat gear selection.

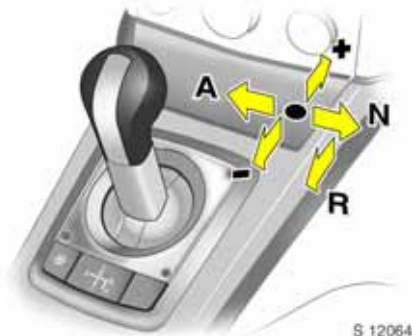

S 12064

Easytronic *:

- N** = Idling
- = Driving position
- +** = Higher gear
- = Lower gear
- A/M** = Switch between Automatic and Manual mode
- R** = Reverse gear (with selector lever lock)

The selector lever must always be moved in the appropriate direction as far as it will go. Upon release, it automatically returns to the centre position. Pay heed to the gear/mode indicator in the transmission display.

The footbrake must be depressed when starting.

► Easytronic * – page 131.



S 11522

Automatic transmission *:

- P** = Park position
- R** = Reverse gear
- N** = Neutral (idling)
- D** = Automatic gear selection
- 3** = 1st to 3rd gear
- 2** = 1st and 2nd gear
- 1** = 1st gear

P or **N** must be engaged when starting.

To leave **P** or **N**, switch on ignition, depress footbrake and press button on selector lever.

Press button on selector lever to engage
P or **R**.

- P** only when the vehicle is stationary,
apply handbrake first
- R** only when the vehicle is stationary
- ▶ Automatic transmission * – page 136.



S 11523

Automatic transmission with ActiveSelect *:

- P** = Park position
- R** = Reverse gear
- N** = Neutral
(idling)
- D** = Automatic gear
selection

Selector lever in D to the left: Manual mode

- +** = Higher gear
- = Lower gear

P or **N** must be engaged when starting.

To leave **P** or **N**, switch on ignition, depress footbrake and press button on selector lever.

Press button on selector lever to engage
P or **R**.

- P** only when the vehicle is stationary,
apply handbrake first
- R** only when the vehicle is stationary
- ▶ Automatic transmission * – page 136.

Before starting-off, check:

- Tyre pressure and tyre condition – see pages 159, 220.
- Engine oil level and fluid levels in engine compartment – see pages 202 to 207.
- All windows, mirrors, exterior lighting and number plates are free from dirt, snow and ice and are operational.
- No objects are placed in front of the rear window, on the instrument panel or in the area in which the airbags inflate.
- Seats, seat belts and mirrors are correctly adjusted.
- Brake operation.

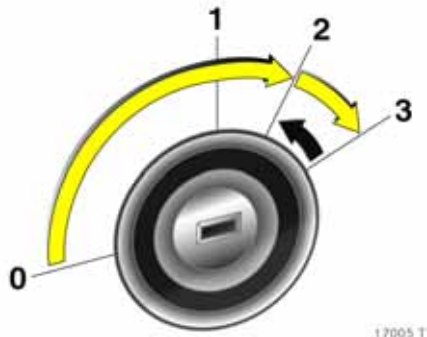
**Start engine:**

**Operate clutch and brake,
automatic transmission *
to P or N,**

**Easytronic *: operate brake,
do not accelerate,**

**Petrol engine: turn key to 3;
Diesel engine: turn key to 2,
when control indicator  goes
off¹⁾, turn key to 3;**

**Release key when engine is
running**

Before restarting or switching off
the engine, turn key back to 0.

To switch on the ignition, only turn the key
to 2.

- ▶ Electronic immobiliser – page 30,
Diesel fuel system – page 203.

¹⁾ Preheating system only switches on at low
outside temperatures.

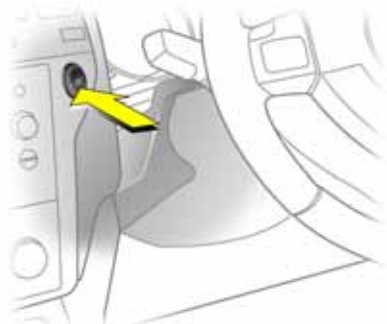

S 1151B

**Start engine,
Open&Start system *:
Electronic key must be within
reception range of the interior,
Operate clutch or brake,
Automatic transmission * in P or
N, Easytronic *: Operate brake,
do not accelerate,
Petrol engine: Press button;
Diesel engine: Briefly press
button, when control
indicator  goes off¹⁾, press
button again for 1 second;
release button when engine is
running**

Press button again to repeat the starting procedure or switch off the engine.

¹⁾ Preheating system only switches on at low outside temperatures.

To switch on the ignition, do not press the brake or clutch pedal and only press the button briefly.

Do not start unless vehicle is stationary.

- ▶ Open&Start system * – page 33,
- Electronic immobiliser – page 30,
- Diesel fuel system – page 203.

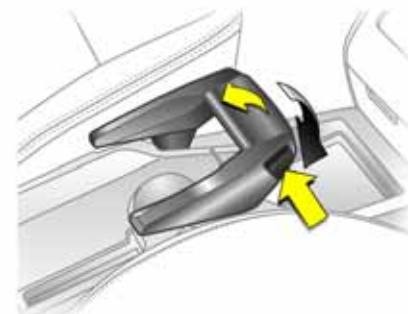



S 11524

**Release handbrake:
Raise handle slightly, press
release button, lower handle all
the way**

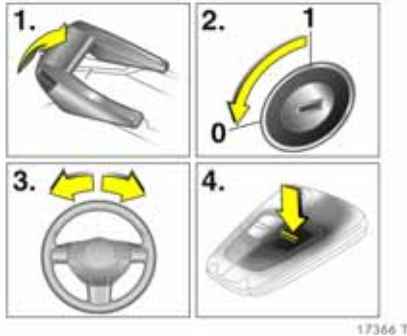



- ▶ Handbrake – page 158.



**Parking the vehicle:
apply handbrake firmly,
switch ignition off,
lock steering wheel,
lock vehicle**



To lock, press button  on the remote control or in the case of the Open&Start system , touch the sensor in one of the front door handles.

With Open&Start system , the driver's door must be opened to lock the steering wheel.

To activate the Vauxhall alarm system , press button  or with Open&Start system , touch sensor in one of the front door handles. To activate the anti-theft locking system , press button  twice.

► For more information – page 30,
Open&Start system – page 33,
Radio remote control – page 32,
Central locking – page 37,
Vauxhall alarm system  – page 42,
Vehicle decommissioning – page 209.

Advice when parking:

- Do not park the vehicle on an easily ignitable surface. The high temperature of the exhaust system could ignite the surface.
- Always apply the handbrake firmly. Apply the handbrake as firmly as possible on uphill or downhill slopes. To reduce operating forces, depress foot brake at the same time.
- Close window.
- Before switching off ignition: with manual transmission, engage first or reverse gear; with automatic transmission , selector lever in **P**; with Easytronic , engage first or reverse gear (note gear indicator – see pages 131, 136).

- In vehicles with automatic transmission * the key can only be removed with the selector lever in position **P**. With the Open&Start system * "P" flashes in the transmission display for several seconds if **P** has not been selected or the handbrake has not been applied.
- On vehicles with Easytronic * control indicator (Ⓢ) flashes for a few seconds after the ignition is switched off if the handbrake has not been applied – see page 84.
- With the Open&Start system * the engine can only be switched off when the vehicle is stationary.
- Turn steering wheel until lock is felt to engage (anti-theft protection), removing ignition key beforehand. With Open&Start system * switch off ignition and open driver's door.
- The engine cooling fans may run after the engine has been switched off – see page 201.
- ▶ Further information – see pages 207, 209.

That was the most important information in brief for your first drive in your vehicle.

The other pages of this chapter contain a summary of the noteworthy functions of your vehicle.

The remaining chapters of the Owner's Manual contain important information on operation, safety and maintenance as well as a complete index.



Seats in second row

⚠ Warning

When the row of seats or the backrests are being adjusted, keep hands away from the hinge area - risk of injury.

Moving seats

Push release handle on right or left hand side of seat bench forwards and move seat row forwards or backwards. Release handle and allow seat row to lock into position.



Adjust backrests of outboard seats

Push down release lever on outboard side of backrest, backrest angle can be adjusted in two places towards the rear. Release handle and latch backrest into position.

The backrest engages in several positions. The seat must not be occupied whilst the vehicle is moving if the seat is in the vertical position or tilted forwards.

The outboard seat backrests can be tilted forwards until they are flat in order to make it easier to enter and exit the vehicle. Push release lever down and tilt backrest forward.

To move the backrest upright or change the position, push release lever down and adjust backrest. Release handle and engage backrest.

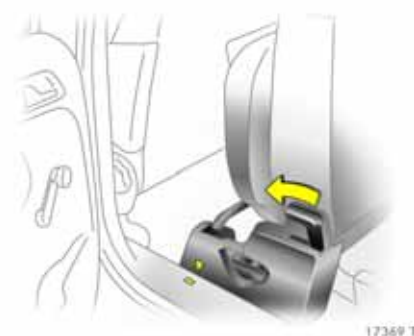

Seats in third row

⚠ Warning

When the seats are being moved upright or folded in, keep hands away from hinge area - risk of injury.

Move seats upright out of vehicle floor

Remove floor covering*.

Removing luggage compartment cover* - see page 57.

Before moving the seats upright, slide seat bench of second row of seats forwards by pushing forward the lever at the right or left-hand side of the seat bench. The tip of the arrow at the seat bench must be in front of the square mark. Slide front seats forwards a little if necessary.



The seat belts must be routed through the belt holder as shown in the illustration. The latch plates must be inserted in the holder.

⚠ Warning

In the version with FlexOrganizer * – see page 60, the belts must be suspended in the right and left seat belt eyes on the floor of the vehicle without twisting – see illustration above and page 67, Fig. 17420 T.

All components must be removed from the rails * in the luggage compartment.



From luggage compartment, use one hand to lift seat by the handle, swivel back and move upright until it audibly engages. Use other hand to support top of backrest, see Fig. 17372 T.



Lift up cover in floor between the seats and swivel belt buckles upwards – see page 22, Fig. 17374 T.

Remove latch plate and seat belt from seat belt holder.

⚠ Warning

The belt must not be routed through the belt holder when the seat belt is being worn.

Move seat bench in second row of seats to required position and engage by pushing lever on right or left-hand side of seat bench forwards – see page 20, Fig. 17367 T.

Fit luggage compartment cover * by fitting behind the third row of seats – see page 57.



Fold seats into floor of vehicle

Removing luggage compartment cover * – see page 57.

Before folding in the seat, slide seat bench in second row of seats forwards by pushing forward lever on right or left-hand side of seat bench – see page 20, Fig. 17369 T. The tip of the arrow on the seat bench must be in front of the square mark. Slide front seats forwards a little if necessary.

Push down head restraints of seats in third row – releasing spring catches by pressing.

Guide seat belts through belt holder as shown in illustration and insert latch plates into holder.



From luggage compartment, press button at top of seat backrest and swivel backrest forward. Raise seat by handle at rear and swivel backrest further forwards until seat is lowered into vehicle floor.

Hold seat by handle during the entire swivelling procedure.

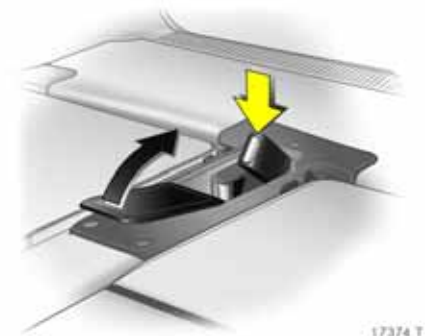

Push belt buckles into recess in floor and close cover.

Move seat bench in second row of seats to required position and engage by pushing lever on right or left-hand side of seat bench forwards – see page 20, Fig. 17367 T.

Fit luggage compartment cover * behind second row of seats – see page 57.

Insert floor cover *.

The components of the rails * and the FlexOrganizer * – see page 60, must only be used with the seats in the third row of seats folded in and the seat belts unhooked – see page 67, Fig. 17420 T. Attach released belt hooks to magnets of bracket – see page 67, Fig. 17399 T.

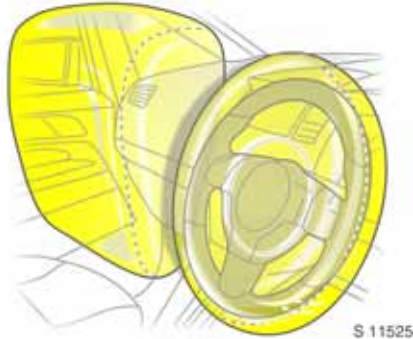

S 11525

Airbag system

The airbag system consists of a number of individual systems.

Front airbag system

The front airbag system is triggered in the event of a serious accident involving a frontal impact and forms safety cushions for the driver and front passenger.

The forward movement of the driver and front passenger is checked and the risk of injuries to the upper body and head thereby substantially reduced.

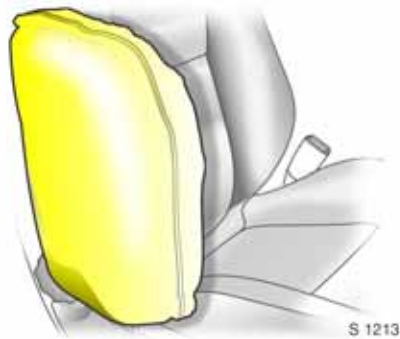

S 12135

Side airbag system *

The side airbag is triggered in the event of a side-on collision to form a safety cushion for the driver or front passenger in the respective door area. This substantially reduces the risk of injury to the upper body and pelvis.

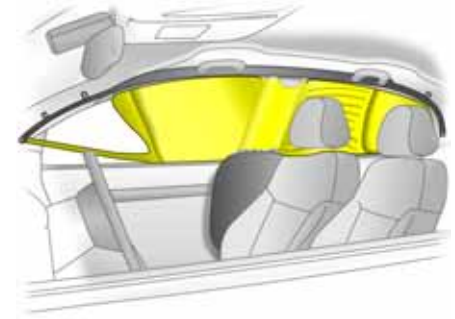

S 12136

Curtain airbag system *

The curtain airbag system triggers in case of a side-on collision and provides a safety barrier in the head area on the respective side of the vehicle. This reduces the risk of injury to the head considerably in case of a side-on collision.

► Airbag system – page 69.



17011 T

Active head restraints* on front seats

In the event of a rear-end impact, the active head restraints tilt forwards slightly. The head is more effectively supported by the head restraint and the risk of injuries caused by whiplash in the neck area is reduced.

Active head restraints are identified by the lettering **ACTIVE** on the head restraint guide sleeves.

► Head restraints – page 51.

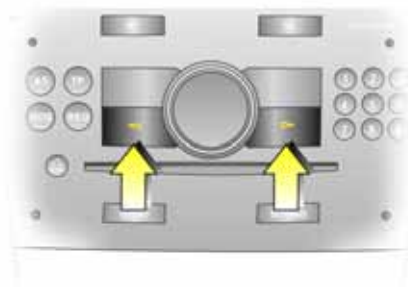

S 13209

Operating menus in the information display*

Menu options are selected via menus and using the arrow buttons or the multi-function knob of the Infotainment system* or the buttons* on the steering wheel. The respective menu options are shown on the display.

Selection using the arrow buttons*: Press the arrow buttons to the left or right.



17013 T

Selection using multi-function knob*: rotate and press multi-function knob.

To exit a menu, turn the multi-function knob left or right to **Return** or **Main** and select.



Selection with left adjuster wheel on steering wheel * : turn adjuster wheel and press.

► Information display – page 89

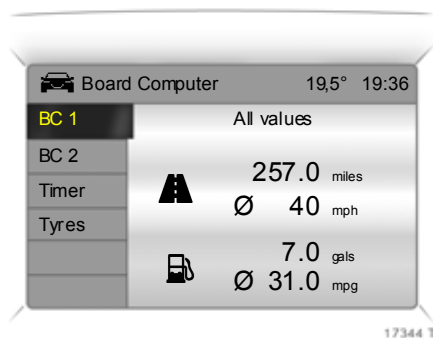

Trip computer *

The trip computers provide information on driving data, which is continually recorded and evaluated electronically.

Functions:

- Range
- Instantaneous consumption
- Distance
- Average speed
- Effective consumption
- Average consumption
- Stop watch
- Tyre pressure *

► Trip computer * – pages 93, 98.

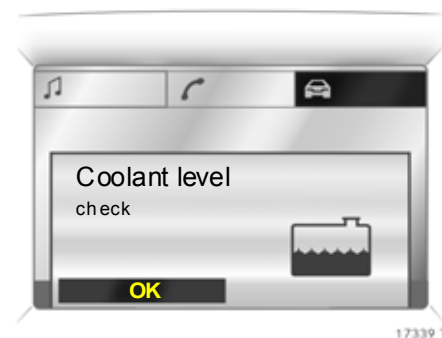

Check control *

The check control software monitors

- Fluid levels
- Tyre pressure *
- Remote control battery
- Vauxhall alarm system *
- Important exterior lighting, including cables and fuses.

► Check control * – page 101.

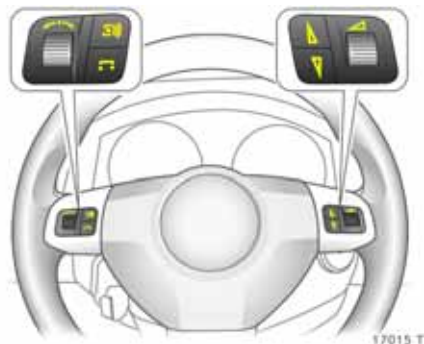

Remote control on steering wheel*

The functions of the Infotainment system* and the information display can be operated with the remote control on the steering wheel.

Further information is available in the Infotainment system operating instructions.

► Remote control on steering wheel* – page 112,
Infotainment system – page 113.



Twin Audio*

Twin Audio provides rear seat occupants with the opportunity to listen to a different audio source than the one selected by the driver on the Infotainment system.

Only an audio source that is not currently active on the radio system can be controlled using Twin Audio.

Two headphone connections are available, with separate volume controls.

Further information is available in the Infotainment system operating instructions.

► Twin Audio* – page 112.



Open&Start system with electronic key and radio remote control*

The Open&Start system allows the vehicle to be locked and unlocked, including mechanical anti-theft locking system* and the Vauxhall alarm system* without a mechanical key and the engine to be started and stopped using a Start/Stop button. All the driver has to do is carry the electronic key around with him.

► Open&Start system* – page 33.



17016 T

Parking distance sensors *

When reverse gear is selected, the parking distance sensors switch on automatically.

The parking distance sensors can also be enabled manually at a speed of less than 15 mph (25 km/h) using the **P** button on the instrument panel.

If the vehicle approaches an obstacle at the front or the rear, a series of acoustic signals is heard in the vehicle interior. The interval between the signals becomes shorter as the obstacle becomes closer. The signal is continuous if the distance is less than 30 cm.

► Parking distance sensors * – page 152.



17961 T

Sport mode *

To activate
Press **SPORT** button.

SPORT mode is used to change damping *, steering *, throttle application and the shift point for Easytronic * and automatic transmission * whilst driving.

Damping and steering become more direct and provide better contact with the road surface. The engine reacts more quickly to accelerator movements.

With Easytronic * and automatic transmission *, the shift times are shortened and shifting takes place at higher revs (not with cruise control enabled *).

► Sport mode * – page 150.



17401 T

FlexOrganizer *

The side walls contain retaining strips, where various components can be attached to divide the luggage compartment or fasten loads.

The system consists of

- adapters
- variable partition net
- mesh pockets for the side walls
- hooks in the luggage compartment

► FlexOrganizer * – page 60.



17018 T

Tyre pressure loss monitoring system (DDS = Deflation Detection System) *

The Deflation Detection System continuously monitors the speed of all wheels whilst driving. If a tyre loses pressure, it becomes smaller and therefore rotates more quickly than the other wheels. If the system detects a difference in speed, the control indicator (⚠) illuminates in red.



17019 T

After a tyre pressure correction or after a tyre or wheel change, the system must be initialised by pressing the DDS button.

► Tyre pressure loss monitoring system * – page 154.

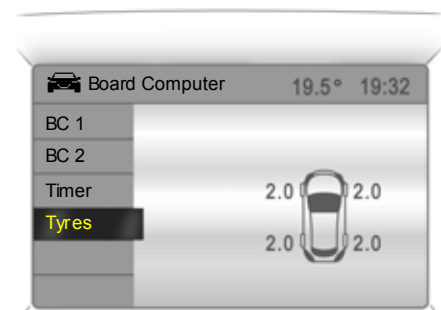

17334 T

Tyre Pressure Monitoring System *

The Tyre Pressure Monitoring System continually checks the pressure and speed of all four wheels whilst driving.

A pressure sensor is installed in each wheel. The inflation pressures of the individual wheels are transmitted to a controller, where they are compared.

The current tyre pressures can be displayed on the Graphical Information Display or the Colour Information Display *.

Deviating tyre pressures are displayed in the form of messages on the information display whilst driving.

► Tyre Pressure Monitoring System * – page 155.

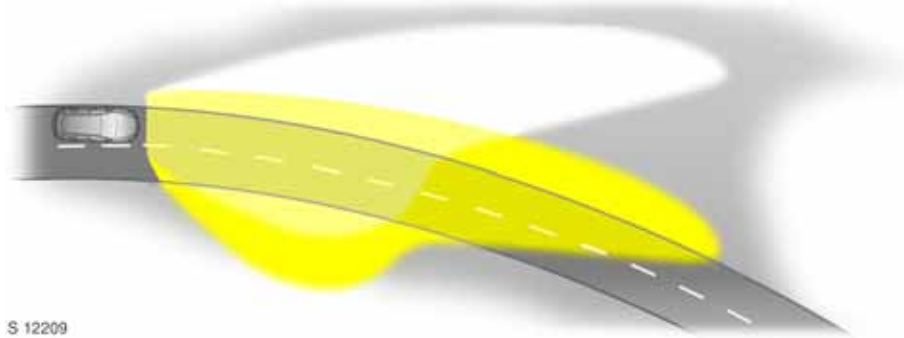

S 12209

Adaptive Forward Lighting (AFL) *

AFL improves lighting in curves (curve lighting) on vehicles with Bi-Xenon headlight system.

Curve lighting

The Xenon light beam pivots based on steering wheel position and speed (from approx. 6 mph (10 km/h)).

Motorway lighting

At higher speeds and continuous straight ahead travel, the dipped beam automatically raises slightly, thereby increasing headlight range.

Adaptive Forward Lighting * – page 108.

Locks, Doors, Windows

Replacement keys	30
Lock cylinders	30
Car Pass.....	30
Key with foldaway key section *.....	30
Electronic immobiliser.....	30
Store personal vehicle settings in the vehicle key *	31
Radio frequency remote control * with mechanical key	32
Open&Start system *.....	33
Central locking system	37
Fault when locking or unlocking.....	40
Luggage compartment	41
Vauxhall alarm system *.....	42
Child safety locks	45
Exterior mirrors.....	45
Interior mirror	46
Electric windows *.....	46
Sunblind on panoramic roof *	48

Replacement keys

The key number is specified in the vehicle documents and in the Car Pass *.

The key is a constituent of the electronic immobiliser. Ordering keys from a Vauxhall Authorised Repairer guarantees problem-free operation of the electronic immobiliser.

When electronic keys of the Open&Start system are being replaced, all keys must be handed to the dealer for programming.

Keep the spare key in a safe place.

Locks – see page 197,
Open&Start system, electronic keys – see page 33.

Lock cylinders

Designed to free-wheel if they are forcefully rotated without the correct key or if the correct key is not fully inserted.

To reset, turn cylinder with the correct key until its slot is vertical, remove key and then re-insert it. If the cylinder still free-wheels, turn the key through 180° and repeat operation.

Car Pass

The Car Pass contains all of the vehicle's data and should therefore not be kept in the vehicle.

Have your Car Pass to hand when consulting a Vauxhall Authorised Repairer.

Key with foldaway key section *



17027 T

Press button to extend. Press button to retract and key section engages audibly.

Electronic immobiliser

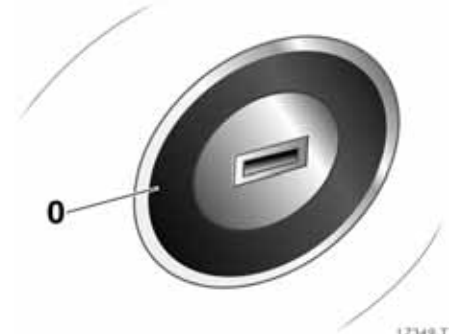

17349 T

The system checks whether the vehicle is allowed to be started with the mechanical key or electronic key of the Open&Start system * that is being used. If the key is recognised as "authorised" the vehicle can be started. The checking takes place via a transponder in the key.

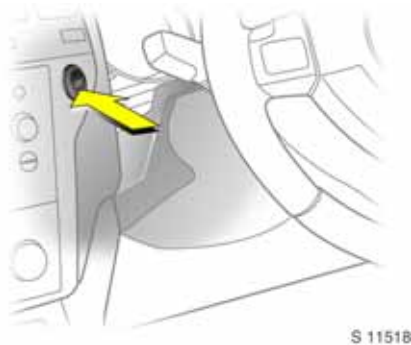

The electronic immobiliser activates itself automatically after the key has been removed from the ignition or, with the Open&Start system *, when the engine is switched off by pressing the Start/Stop button.

The code number of the electronic immobiliser is given in the Car Pass.

Control indicator for immobiliser



Control indicator  illuminates briefly when the ignition is switched on.

If the control indicator flashes when the ignition is on, there is a fault in the system; the engine cannot be started. Switch off the ignition and then repeat the start attempt.

If the control indicator  continues flashing, attempt to start the engine using the spare key and seek the assistance of a workshop.

If control indicator  illuminates after the engine is started, there is a fault in the engine electronics or transmission electronics * (see pages 135, 140, 147) or there is water in the diesel fuel filter * – see page 203.

Note

The immobiliser does not lock the doors. Therefore, after leaving the vehicle always lock it and switch on the Vauxhall alarm system * – see pages 38, 42.

Store personal vehicle settings in the vehicle key *

The last settings selected

- for the Electronic Climate Control (ECC) *
- information display *
- Infotainment system *
- instrument illumination

are stored automatically depending on the vehicle key used.

Different settings are stored for each vehicle key. Use of a vehicle key will activate the settings associated with it.

Each time the vehicle is locked, the settings are saved again.

Radio frequency remote control * with mechanical key



17029 T

Depending on the equipment level of your vehicle, one of the remote controls shown on this page will be used.

Radio frequency remote control in version with Open&Start system * – see page 34.

The remote control is integrated in the key.

Used to operate:

- Central locking system,
- Mechanical anti-theft locking system *
- Vauxhall alarm system *.

The windows of vehicles with electric windows in all doors * can also be opened or closed using the remote control – see page 46.



17030 T

The remote control has a range of approx. 5 metres. This range can be affected by outside influences. Aim the remote control at the vehicle to operate.

Handle the remote control with care, protect it from moisture and high temperatures and avoid unnecessary operation.

Function check by illumination of hazard warning lights.

Central locking system, mechanical anti-theft locking system *
see page 37.

Vauxhall alarm system *
see page 42.

Electric windows *
see page 46.

Fault

If the central locking system cannot be operated with the remote control, it may be due to the following:

- The range of the remote control has been exceeded.
- Remote control battery voltage is too low. Battery replacement – see next page.
- Frequent, repeated operation of the remote control outside the reception range of the vehicle (e.g. too far from vehicle, remote control is then no longer recognised). Remote control synchronisation – see next page.
- Overloading the central locking by operating at frequent intervals, the power supply is interrupted for a short time.
- Interference from higher-power radio waves from other sources.

To rectify the cause of the fault, we recommend that you seek the assistance of a workshop.

Open driver's door with key – see page 40.

Remote control battery replacement

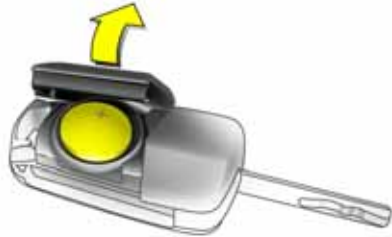

17031 T

Replace the battery as soon as the range of the remote control begins to shrink.

Key with foldaway key section

Extend key – see page 30. Open remote control. Replace battery - battery type – see page 223 – noting installation position. Close remote control.

Make sure that you dispose of old batteries in accordance with environmental protection regulations.

Key with fixed key section

Have the battery replaced by a workshop.

In the event of a malfunction or when the battery has been replaced, synchronise the remote control

After replacing the battery, unlock the door with the key in the lock. The remote control will be synchronised when you switch on the ignition.

Open&Start system ✱



S 11519

The Open&Start system allows the vehicle to be locked and unlocked, including the mechanical anti-theft locking system ✱ and the Vauxhall alarm system ✱, and the engine to be started and stopped without a mechanical key. All the driver has to do is keep the key to hand.

The windows of vehicles with electric windows in all doors ✱ can also be opened or closed from outside using the remote control of the electronic key – see page 40.



S 11526

The electronic key must be within the external reception range about 1 metre from the vehicle in order to lock and unlock the vehicle.

If the electronic key is recognized as "authorised" the vehicle can be unlocked by pulling a door handle or by operating the button beneath the tailgate handle and the doors and the tailgate can be opened.

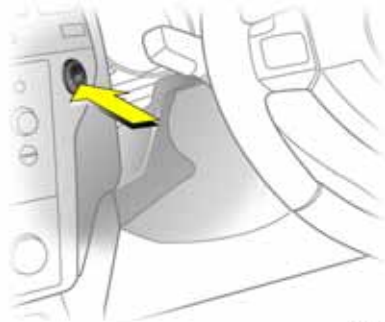

S 1151B

When the Start/Stop button is pressed, the system re-checks the authorisation. The electronic key has to be recognised in the interior in order to do this. After the key has been authorised the ignition switches on. At the same time, the electronic immobiliser is switched off and the electro-mechanical steering column lock is deactivated. Pressing the Start/Stop button again with the brake or clutch pedal depressed or in **P** or **N** with automatic transmission * starts the engine. Press button for at least one second with the vehicle stationary or hold down until the engine starts.

If the brake or clutch pedal is depressed, the engine can be started right away with a single press on the Start/Stop button.

Releasing the Start/Stop button interrupts the starting procedure.

The engine and the ignition are switched off by pressing the Start/Stop button again. The vehicle must be stationary. The immobiliser is activated at the same time.

If the ignition has been switched off and the vehicle is stationary, the steering column lock activates automatically when the driver's door is opened or closed.

The electronic key must be within the reception range of the interior to turn the ignition on or off. We recommend that the driver carries the electronic key with him. If the electronic key is not recognised, select another key position.

Do not put the electronic key in the luggage compartment or in front of the information display.

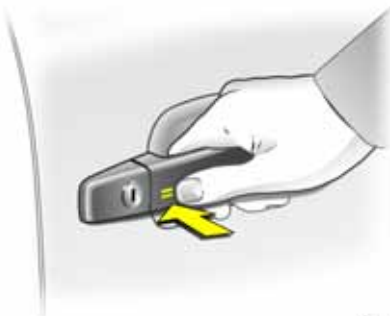

S 11527

The vehicle is locked from the outside with the doors closed by touching the sensor panel in the door handle of one of the front

doors. The electronic key must be within the external reception range of approximately one metre from the vehicle.

The Open&Start system * does not lock the vehicle automatically if the electronic key is outside the external reception range of approximately one metre from the vehicle.

Radio frequency remote control

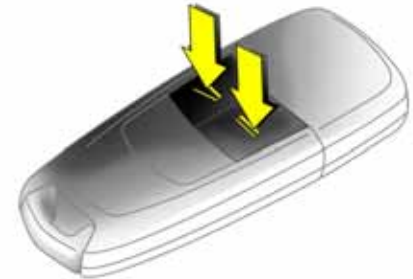

17035 T

The vehicle can be locked and unlocked by conventional means using the remote control with the buttons on the electronic key.

In addition, the mechanical anti-theft locking system and Vauxhall alarm system can be armed and disabled using the remote control. The windows of vehicles with electric windows in all doors * can also be opened or closed from outside using the remote control.

The remote control has a range of approx. 5 metres. This range can be affected by outside influences. Aim the remote control at the vehicle to operate.

Handle the remote control with care, protect it from moisture and high temperatures and avoid unnecessary operation.

Function check by illumination of hazard warning lights.

Central locking system, mechanical anti-theft locking system *

see page 37.

Vauxhall alarm system *

see page 42.

Electric windows *

see page 46.

Control indicator for Open&Start system 





17036 T

If the control indicator flashes  with the ignition switched on or with the engine running an operating error has occurred, e.g. the electronic key is no longer within the reception range of the vehicle interior. During the next starting procedure the engine may not be able to be started. Press Start/Stop key slightly longer to switch the ignition off.

Flashing of the  can also be an indication of complete failure of the electronic key. In this case operation is only possible using the emergency facility – see next column.

InSP3 in the service display or an appropriate message in the information * display indicates that the battery of the electronic key needs replacing – see page 36.

If the control indicator  is permanently on, an error has occurred in the system. Lock or unlock vehicle using the remote control or the emergency key if necessary – see page 37, or try using the spare key.

If  illuminates, this can also mean that the steering column lock is still locked: move steering wheel to and fro a little and press Start/Stop button again.

If this  comes on when the vehicle is in motion, there is a system error. Seek the assistance of a workshop immediately.

Emergency operation

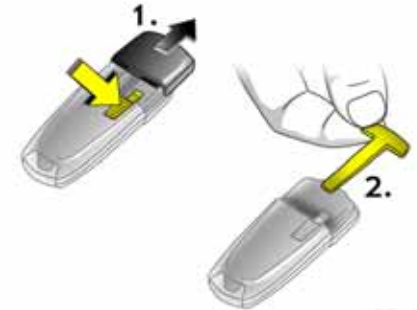

17037 T

If the Open&Start system or the electronic key fails (control indicator  flashes or is permanently on) the driver's door can be locked or unlocked with the emergency key in the electronic key: press locking mechanism on underside and remove cap towards the front by applying gentle

pressure to the cap. Push emergency key towards the outside over the detent position and remove.

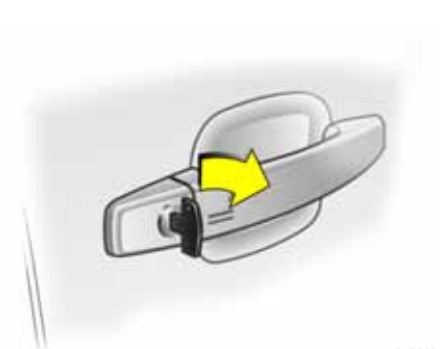

S 11528

Only the driver's door can be locked and unlocked using the emergency key. The entire vehicle is unlocked as described on page 41.

The Vauxhall alarm system* may be triggered when the vehicle is unlocked. Switch ignition on to deactivate alarm and release the steering column lock: hold electronic key at marked position on the steering column panelling and press the Start/Stop button. Repeat procedure if necessary.

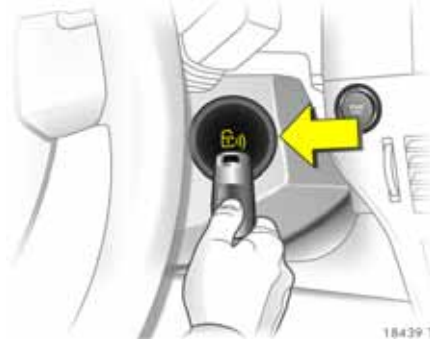

Hold electronic key at the marked location to start the engine, depress brake pedal or clutch pedal or in vehicles with automatic transmission * depress brake pedal and select **P** or **N**. Then press Start/Stop button again.

Press Start/Stop button for at least 2 seconds to switch the engine off. Lock all doors except driver's door as described on page 41. Lock driver's door with emergency key.

This option is intended for emergencies only. Replace the battery in the electronic key as quickly as possible or have the system repaired. Seek the assistance of a workshop.

Replacing battery in electronic key



Replace battery immediately if the system is no longer operating properly, or the range of the remote control deteriorates. The need for a battery change is indicated by **InSP3** in the Service Display or in vehicles with check control * an appropriate message appears on the display – see page 101.



17041 T

To replace the battery, press the locking mechanism on the underside of the electronic key and remove the cover towards the front by applying gentle pressure – see page 35, Fig. 17037 T. Push off cover with emblem on the button side towards the outside.

Replace battery, for battery type – see page 223, pay attention to installation position. Engage caps.

Radio frequency remote control synchronisation

The remote control synchronises itself automatically during every starting procedure.

Fault in Open&Start system or remote control

If the central locking cannot be operated or the engine cannot be started, the cause may be one of the following:

- Electronic key out of reception range, or out of range of remote control,
- Remote control battery voltage is too low. Battery replacement – see page 36,
- Frequent, repeated operation of the remote control outside the reception range (e.g. too far from vehicle, remote control is then no longer recognised),
- Overloading the central locking by operating at frequent intervals, the power supply is interrupted for a short time,
- Interference from higher-power radio waves from other sources.

To rectify the cause of the fault, change the position of the electronic key or remote control or replace the battery in the remote control. If the fault persists, seek the assistance of a workshop.

Emergency operation – see page 35.

Central locking system

For doors, boot lid/tailgate and tank flap.

To unlock:

Remote control with mechanical key



16968 T

Press button  on remote control.

To open the door, pull the handle. Open the luggage compartment by operating the button beneath the tailgate handle.

Open&Start system with electronic key *

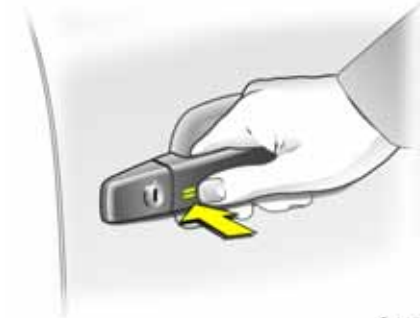

S 11527

The electronic key must be outside of the vehicle. The vehicle is unlocked by pulling a door handle or by operating the button beneath the tailgate handle.

– or –
Press button  of the electronic key's remote control.

To lock

Close doors, luggage compartment and tank flap.

Remote control with mechanical key



17042 T

Press button  on remote control.

Open&Start system with electronic key *

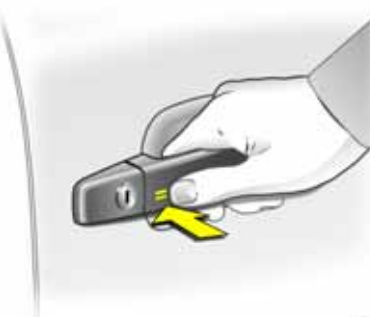

S 11527

The electronic key must be outside of the vehicle. All doors and the luggage compartment are locked by touching the sensor in the door handle of the driver's or front passenger's door

– or –
Press button  of the electronic key's remote control.

Mechanical anti-theft locking system *

 **Warning**

Do not use the system if there are people in the vehicle! The doors cannot be unlocked from inside.

Remote control with mechanical key

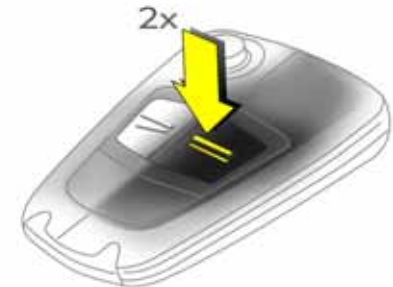

17043 T

All doors must be closed. At the latest 15 seconds after locking, press button  of the remote control again.

Lock buttons on all doors are positioned such that doors cannot be opened.

If the ignition was on, the driver's door must be opened and closed once so that the vehicle can be secured.

Open&Start system with electronic key *

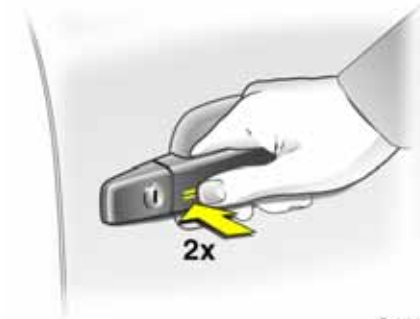

S 11530

All doors must be closed. The electronic key must be outside of the vehicle. No more than 15 seconds after locking, touch the sensor in the handle of the driver's or front passenger's door again

– or –
press button of the electronic key's remote control again.

If the ignition was on, the driver's door must be opened and closed once so that the vehicle can be secured.

All doors are secured against opening.

Central locking button for locking and unlocking the doors from inside the vehicle



Press button in the centre console: doors are locked or unlocked.

The LED in the central locking button illuminates for around 2 minutes after locking with the remote control.

If the doors are locked from the inside during driving using the central locking button, the LED illuminates permanently.

If the key is in the ignition *, locking is only possible if all doors are closed.

When the mechanical anti-theft locking system * is active – see page 38, the doors cannot be unlocked with this button.

Note

- If the driver's door is not closed properly, the central locking system will not lock.
- To lock the doors from within (e.g. to prevent unwanted entry from outside), press central locking switch in the centre console.
- After unlocking with the key in the lock * and opening the driver's door, the entire vehicle is unlocked.
- If the central locking system is locked, the doors can also be unlocked by pulling the interior handle. This unlocks the central locking system.
- Locked doors unlock themselves automatically when an accident of a certain severity occurs (for outside assistance), and the hazard warning lights come on. In the version with a mechanical key, the key must also be in the ignition.
- With the Open&Start system * the vehicle cannot be unlocked within 2 seconds of locking. Within this time a door handle can be pulled or the button beneath the tailgate handle operated to check whether the vehicle is locked.
- The Open&Start system * does not lock the vehicle automatically if the electronic key is outside the reception range of the vehicle (more than 1 metre away from the vehicle).

- A spare key must not be present in the vehicle with the Open&Start system * when the vehicle is being locked.
- The locking sensors in the door handles must be kept clean for unrestricted functionality with the Open&Start system *.

Operating the windows * from the outside

⚠ Warning

Take care when operating the electric windows. Risk of injury, particularly to children.

Vehicle passengers must be informed accordingly.

Keep a close watch on the windows when closing them. Ensure that nothing becomes trapped in them as they move.

Depending on the vehicle equipment *, the windows can be opened and closed from the outside in vehicles with power windows in all doors.

Remote control with mechanical key

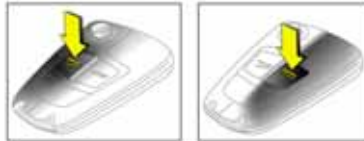

S 11531

Hold button \geq or $=$ on the remote control depressed until all windows have opened or completely closed.

Open&Start system with electronic key *

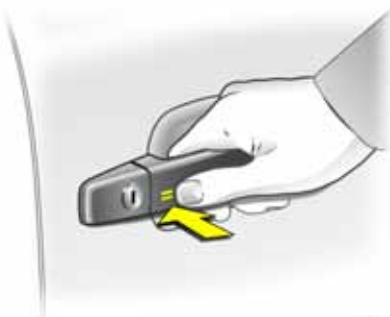

S 11527

Hold down button \geq of remote control to open. To close, hold down button $=$ or touch sensor in door handle for longer. The electronic key must be recognised within the external reception range. It is advisable for the driver to keep the electronic key to hand.

Further information on windows – see page 46.

Fault

- Overloading the central locking by operating at frequent intervals, the power supply is interrupted for a short time,
- Defective fuse in fusebox – see page 184.

To rectify the cause of the fault, seek the assistance of a workshop.

Fault when locking or unlocking



S 11532

Fault in remote control or Open&Start system *

To unlock

Turn key or emergency key with Open&Start system * – see page 35, forwards in driver’s door lock as far as it will go. Turn key back to a vertical position and remove. The entire vehicle is unlocked when the driver’s door is opened. The vehicle is unlocked (not possible if anti-theft locking system * enabled beforehand). To deactivate the anti-theft locking system * switch ignition on. Emergency operation of the Open&Start system * – see page 35.

To lock

Open front passenger’s door, close driver’s door, press driver’s door lock button  in centre console. Central locking system locks all doors. Close front passenger’s door.

Malfunction in central locking system

To unlock

Turn key or emergency key with Open&Start system * – see page 35, forwards in driver’s door lock as far as it will go. Turn key back to a vertical position and remove. The other doors can be opened by pulling the handle inside the doors (not possible if anti-theft locking system * enabled beforehand). The luggage compartment and fuel filler cap remain locked. To deactivate the anti-theft locking system * switch ignition on – see page 44.



To lock

With the Open&Start system * – see page 35. To lock passenger’s door, insert key or emergency key into opening above lock on inside of door and operate lock by pressing (audible) and close door. Procedure must be carried out for every door. Driver’s door can be locked from the outside. The unlocked fuel filler cap and the tailgate cannot be locked.

Emergency operation of Open&Start system *, see page 35.

Luggage compartment

To unlock

Remote control with mechanical key
Press button  on the remote control, the luggage compartment and doors are unlocked.

Open&Start system with electronic key *

Operating the button beneath the tailgate handle unlocks and opens the luggage compartment together with the doors if the electronic key is recognized outside of the car,

– or –

Press button  of the electronic key’s remote control, the luggage compartment will be unlocked together with the doors.

To open



The luggage compartment is opened by operating the button beneath the handle.

 Warning
<p>Do not drive with the tailgate open or ajar, e.g. when transporting bulky objects, since toxic exhaust gas could penetrate the interior.</p>

Fitting of accessories on the tailgate will increase its weight. If it becomes too heavy, the tailgate will then not stay open.

To close



Close luggage compartment using handle on the inside of the tailgate.

Do not operate the button beneath the handle when closing. Otherwise the luggage compartment will once again be unlocked.

To lock

Close doors, luggage compartment and tank flap.

Remote control with mechanical key



Press button  on remote control.

Open&Start system with electronic key*

Press button  of the electronic key remote control or touch sensor in handle of one of the front doors. The electronic key must be recognised in the external reception area. It is advisable for the driver to keep the electronic key to hand.

Vauxhall alarm system *

The system monitors

- the doors, luggage compartment, bonnet,
- the passenger compartment,
- vehicle tilt, e.g. if it is raised,
- the ignition.

To activate

Remote control with mechanical key



All doors, windows and the bonnet must be closed. Press remote control button  to arm the anti-theft alarm system and lock the vehicle.

If the ignition was switched on, the driver's door must be opened and closed once so that the anti-theft alarm system can be switched on.

Open&Start system with electronic key *

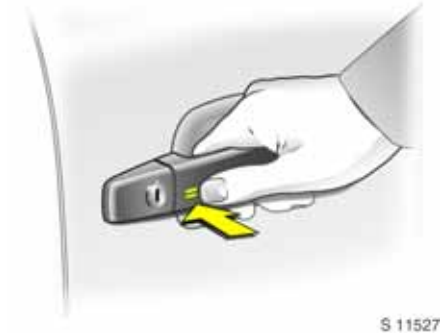

S 11527

All doors, windows and the bonnet must be closed. The electronic key must be outside of the vehicle. Touch the sensor in the handle of the driver's or front passenger's door

– or –

Press button  of the electronic key's remote control.



If the ignition was switched on, the driver's door must be opened and closed once so that the anti-theft alarm system can be switched on.

Activation without monitoring of passenger compartment and vehicle tilt



S 11534

Switch on when, for example, animals are to be left in the vehicle.

1. Close tailgate and bonnet.
2. Press button  in the roof console. The LED in button  flashes (max. 10 seconds) – see next column
3. Close doors.
4. Switch on anti-theft alarm system. LED illuminates. After approx. 10 seconds the system is activated, without monitoring of the passenger compartment or vehicle tilt. LED flashes until system is switched off.

Light emitting diode (LED)



17051 T

During the first 10 seconds of anti-theft alarm system activation:

- LED = Test, ignition delay, illuminates.
- LED flashes quickly = Door, luggage compartment, bonnet open or system fault.

After the first 10 seconds of anti-theft alarm system activation:

- LED flashes slowly = System switched on,
- LED comes on for approx. 1 second = Switch off function.

If a system fault occurs, seek the assistance of a workshop.

To deactivate

Remote control with mechanical key



16968 T

Press button  on remote control
 – or –
 Switch on ignition.

Open&Start system with electronic key *



S 11526

The vehicle is unlocked by pulling a door handle or by operating the button beneath the tailgate handle and the anti-theft alarm system is deactivated when the electronic key is recognized as being outside of the vehicle.

– or –
 Press button  of the electronic key's remote control.

In the event of a fault in the remote control or the Open&Start system, open the vehicle as described on page 40.

If the alarm is triggered when the driver's door is opened, deactivate the anti-theft alarm system by switching on the ignition.

Note

Changes to the vehicle interior, such as the use of seat covers, could impair the function of passenger compartment monitoring.

Alarm

While the anti-theft alarm system is switched on the alarm can be triggered, indicated by:

- an acoustic signal (horn) and
- a visual signal (hazard warning lights).

The number and duration of the alarms are legally established.

The alarm can be silenced by pressing a button on the remote control or by switching on the ignition. The anti-theft alarm system is deactivated at the same time.

Alarm siren

with integrated battery *

The alarm siren monitors the on-board voltage network and triggers an alarm if this network is manipulated (e.g. if the vehicle's battery is disconnected by unauthorised persons). The alarm siren has its own power supply and is therefore not dependent on the vehicle's battery.

If the vehicle's battery is to be disconnected (e.g. for maintenance work), the alarm siren must be deactivated as follows: switch the ignition on then off, disconnect the vehicle's battery within 15 seconds.

To switch off alarm siren:

Switch ignition on then off.

Child safety locks

Warning

Use the child safety lock whenever children are occupying the rear seats. Disregard may lead to injuries or endanger life. Vehicle passengers must be informed accordingly.



17052 T

Using key or screwdriver, turn rotary knob at rear door lock from the vertical position: door cannot then be opened from inside.

Exterior mirrors

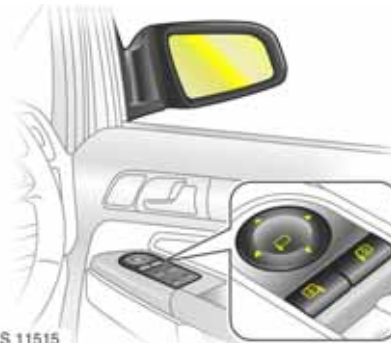

S 11515

Adjust using the four-way switch in the driver's door. Press mirror switch to the right or left. The four-way switch works on the corresponding mirror.

The mirror glass is moved in the direction which corresponds to the pressing of the four-way switch.

Aspherical exterior mirror *

Increases the field of view. Estimating the distance away of vehicles following you is only possible to a limited extent because of slight distortion.

Swing in exterior mirror

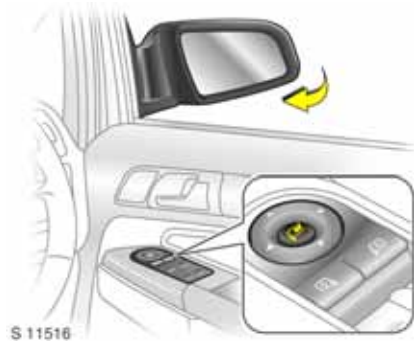



S 11516

Manually: the exterior mirrors can be folded in by pressing gently on the outer edge of the housing.

Electrically *: Press  and both mirrors will swing in.

Press button  again - both exterior mirrors swivel to the starting position.

If a swivelled-in electric mirror has been swivelled out manually, pressing button  only swivels the other mirror out electrically. Pressing  again swivels both mirrors back in electrically.

Fold mirrors out to driving position before moving away.



S 11550

For the safety of pedestrians, the exterior mirrors will swing out of their normal mounting position if they are bumped with sufficient force. Reposition the mirror by applying slight pressure to the mirror housing.

Interior mirror

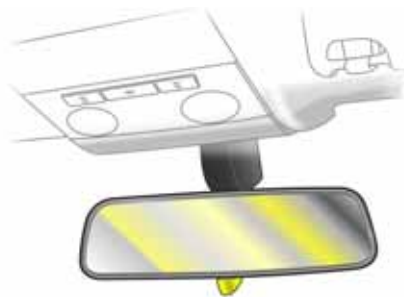

S 11514

To adjust, swivel the mirror housing.

To reduce dazzle from following vehicles at night, swivel lever on underside of mirror housing.

Automatic anti-dazzle interior mirror *



S 11551

Dazzle from following vehicles at night is automatically reduced.

With the ignition off, the mirror does not dim.

Electric windows *

Warning

Take care when operating the electric windows *. Risk of injury, especially for children. Inform the passengers accordingly.

If there are children on the rear seat, switch on the child safety system * for the electric windows.

Keep a close watch on the windows when closing them. Ensure that nothing becomes trapped in them as they move.

The electric windows can be used

- with ignition on,
- within 5 minutes of switching ignition off *,
- within 5 minutes of switching ignition key to position 1.

Function standby after switching off the ignition terminates when the driver's door is opened.



S 11552

Operated via two or four * switches in the driver's door armrest. The front switches are for the driver's and front passenger's doors. The rear switches * are for the rear doors. Additional switches are located in the front passenger's door and rear doors *.



S 11553

For incremental operation, briefly pull or press the switch. For a automatic opening or closing, pull or press the switch longer. Pull or press the switch again to stop the movement.

Safety function

If the window glass encounters resistance above the middle of the window during automatic closing, it is immediately stopped and the window opened again.

In the event of difficulty due to frost or the like, press the relevant window switch several times until the window is closed.

Child safety system for rear windows *



S 11555

Switch  between the rear switches in the driver's door armrest

■ Forwards (red field visible): Rear door switches non-operational

■ Rearwards (green field visible): Rear door switches operational



Operating windows from outside *

Depending on the vehicle equipment, the windows can be opened and closed from the outside using the remote control in vehicles with power windows in all doors.

Remote control with mechanical key





S 11531

Hold button  or  on the remote control depressed until all windows have opened or completely closed.

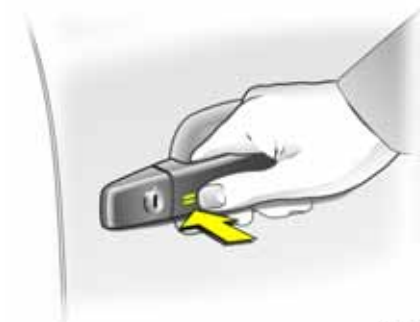
Open&Start system with electronic key *



S 11527

Hold down button  of remote control to open. To close, hold down button  or touch sensor in door handle for longer. The electronic key must be recognised within the external reception range. It is advisable for the driver to keep the electronic key to hand.

Function standby after switching off the ignition terminates when the driver's door is opened.

Overload

If the windows are repeatedly operated at short intervals, the power supply is briefly cut off.

The system is protected by fuses in the fusebox – see page 184.

Fault

If automatic opening and closing of the windows is not possible, activate the window electronics as follows:

1. Close doors.
2. Switch on ignition.
3. Open windows completely.
4. Close the window and hold the button depressed at least 5 seconds.
5. Repeat for each window.

Sunblind on panoramic roof *

To reduce the amount of glare in the interior.



S 14314

To open

Press button  and sunblind opens as far as it will go.

To close

Press button .

For reasons of safety, the blind closes from its open position to approx. 20 cm. Hold down button  to close completely.

Seats, Interior

Front seats	49
Head restraints	51
Armrest *	52
Moving third row seats upright	53
Luggage compartment extension	54
Luggage compartment cover *	57
Safety net *	58
Lashing eyes *	60
Rails * and hooks * in luggage compartment	60
FlexOrganizer *	60
Floor covering * in luggage compartment	62
Notes on loading the vehicle	62
Three-stage restraint system	63
Three-point seat belts	63
Belt tensioners	64
Using the belts	65
Child restraint systems *	68
Mounting brackets * for ISO-FIX child restraint systems	68
Fastening eyes * for Top-Tether child restraint systems	69
Airbag system	69
Cigarette lighter *	78
Accessory socket *	78
Ashtrays *	79
Foldaway tables *	79
Stowage compartments	79
Drink holders *	81
Sunvisors	81

Front seats



Warning

Important: Do not sit nearer than 10 inches (25 cm) from the steering wheel, to permit safe airbag deployment.

Never adjust seats whilst driving as they could move uncontrollably.

Adjust seat longitudinally



S 11510

To adjust, pull handle on front seat, slide seat and release handle.

Adjust seat backrest



S 11511

To adjust, turn hand wheel at side of seat while releasing any load on the seat backrest.

Move seat backrest to suit seating position.

Adjust seat height *

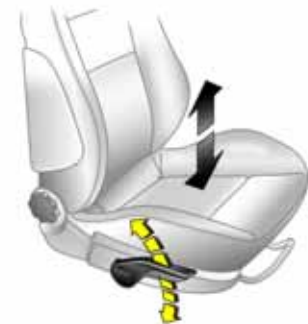

S 11512

To adjust, use lever on the outside of the seat.

Lever pumping motion

Up: Seat higher

Down: Seat lower

Adjust seat incline *

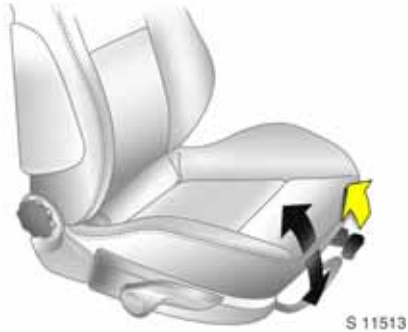

To adjust, pull inner lever on front of seat, adjust inc line and release lever.

Allow the seat to engage audibly

The incline is adjusted by shifting your body weight.

Adjust lumbar support *

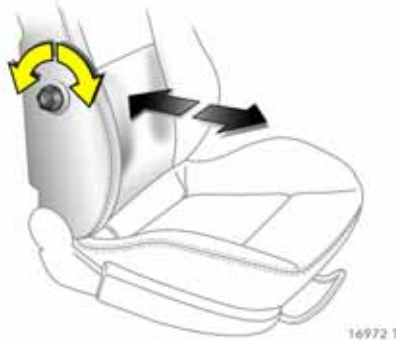

To adjust, turn handwheel on side of seat backrest, releasing the load on the backrest.

Adjust lumbar support to suit personal requirements.

Adjust thigh support * of sports seats *

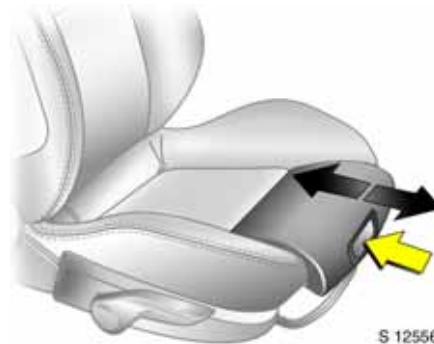

To adjust, press button at the front of the adjustment cushion and slide thigh support.

Adjust thigh support to suit personal requirements.

Seat position



Adjust driver's seat such that with the driver sitting upright the steering wheel is held in the area of its upper spokes with the driver's arms slightly bent.

Push front passenger's seat as far back as possible.

The seat backrests must not be tilted too far back (recommended maximum tilting angle approx. 25°).

⚠ Warning

Failure to observe the instructions could lead to injuries which could be fatal. Vehicle passengers must be informed accordingly before starting-off.

Head restraints

Adjusting the front head restraints and outboard rear head restraints in the second seat row

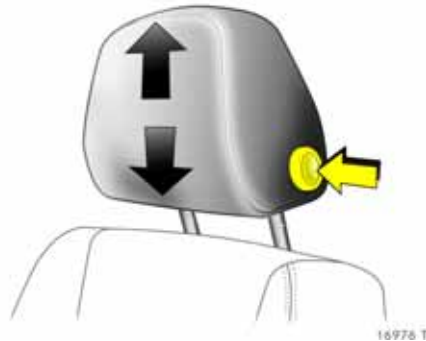

To adjust, press button on side and adjust height.

If the seats are occupied, adjust height according to body size.

Adjusting the head restraints of the centre seat in the second row and the head restraints of the seats in the third row

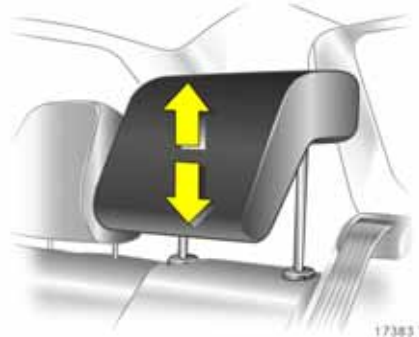

To adjust, pull the head restraint up or press the catch to release. Then push the head restraint down.

To fold the seats or in order to improve visibility when the seats are unoccupied, fold headrests all the way down.

If the seats are occupied, adjust height according to body size.

Head restraint position

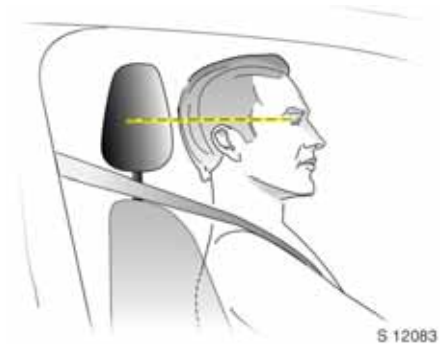

The middle of the head restraint should be at eye level. If this is not possible for extremely tall persons, set to highest position, and set to lowest position for small persons.

⚠ Warning

Failure to observe the descriptions could lead to injuries which could be fatal. Vehicle passengers must be informed accordingly before starting-off.

Active head restraints *



In the event of a rear-end impact, the active head restraints tilt forwards. The head is more effectively supported by the head restraint and the danger of whiplash in the neck area of the cervical vertebra is reduced.

Active head restraints are identified by the lettering **ACTIVE** on the head restraint guide sleeves.

Removing the head restraints

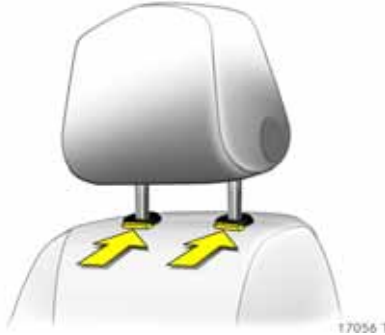

Press and release the two catches. Pull and remove the head restraint.

Note

Only attach loose objects or components to the head restraint on the front passenger's seat if it is not in use.

Armrest *

Armrest at driver's seat

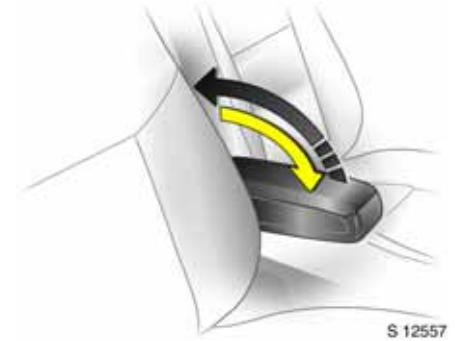

Push raised armrest backwards against resistance and fold down.

The armrest can be moved to different positions in stages by lifting it.

Armrest in folded-down centre backrest



Slide centre headrest all the way down by pressing the catches – see page 51. Pull handle at back of centre backrest, fold backrest onto seat cushion and engage – see page 56.

The centre seat back rest can be used as an armrest when folded down, and contains drink holders and stowage compartments. To erect the seat backrest, pull handle on backrest, straighten backrest and engage.

Moving third row seats upright

Warning

Keep hands away from hinge area when the seats are being moved upright, - risk of injury.

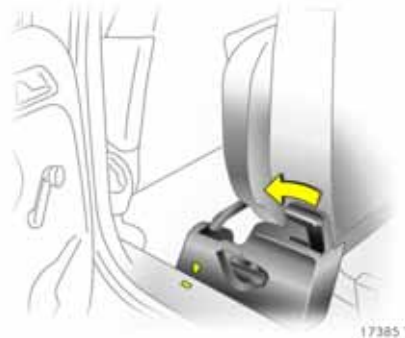

Remove floor covering *.

Removing luggage compartment cover * – see page 57.

Before moving the seats upright, slide seat bench of second row of seats forwards by pushing forward the lever at the right or left-hand side of the seat bench. The tip of the arrow at the seat bench must be in front of the square mark. Slide front seats forwards a little if necessary.



The seat belts must be routed through the belt holder as shown in the illustration. The latch plates must be inserted in the holder.

Warning

In the version with FlexOrganizer * – see page 60, the belts must be suspended in the right and left seat belt eyes on the floor of the vehicle without twisting, see Fig. 17420 T on page 67.

All components must be removed from the rails in the luggage compartment.



17371 T

From luggage compartment, use one hand to lift seat by the handle, swivel back and move upright until it audibly engages. Use other hand to support top of backrest, see Fig. 17372 T.



17372 T

Lift up cover in floor between the seats and swivel belt buckles upwards, see Fig. 17386 T.

Remove latch plate and belt from fixture.

Warning

The belt must not be routed through the belt holder when the seat belt is being worn.

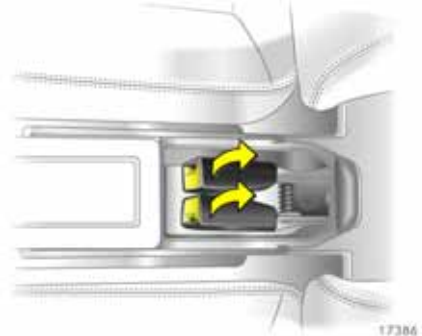

17386 T

Move seat bench in second row of seats to required position and engage by pushing lever on right or left-hand side of seat bench forwards – see page 20, Fig. 17367 T.

Fit luggage compartment cover * by fitting behind the third row of seats – see page 58.

Luggage compartment extension

The greatest amount of luggage compartment space is obtained by removing the luggage compartment cover * and folding the seats of the second and third row as well as the front passenger's seat *, see following description.

Warning

Keep hands away from hinges when folding seats or rows of seats, risk of injury.

The backrests of the seats in the second row may only be moved to the vertical position or tilted forwards in order to extend the luggage compartment. Passengers must not sit in the seats if they are in this position.

Lowering seats in third row into floor of vehicle

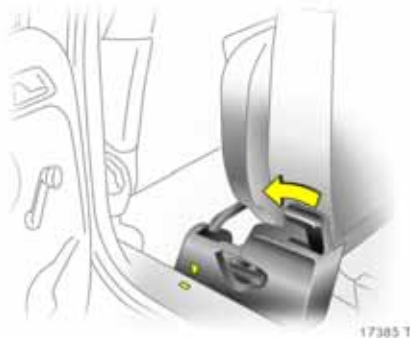

Removing luggage compartment cover * – see page 57.

Before folding the seats in, slide seat bench of second row of seats forwards by pushing forward the lever at the right-hand or left-hand side of the seat bench. The tip of the arrow at the seat bench must be in front of the square mark. Slide front seats forwards a little if necessary.

Push down head restraints of seats in third row – releasing spring catches by pressing.



17370 T

Guide seat belts through holder as shown in illustration and insert latch plates into holder.

If the FlexOrganizer * components are used – see page 60, the seat belts of the third row of seats can be unhooked from the floor of the vehicle – see page 67, Fig. 17420 T. Secure detached belt hooks to holder magnets – see page 60 Fig. 17399 T.



17371 T

From luggage compartment, press button at top of seat backrest and swivel backrest forward. Raise seat by handle at rear and swivel backrest further forwards until seat is lowered into vehicle floor.

Hold seat by handle during the entire swivelling procedure.



17387 T

Lower both seats if required.

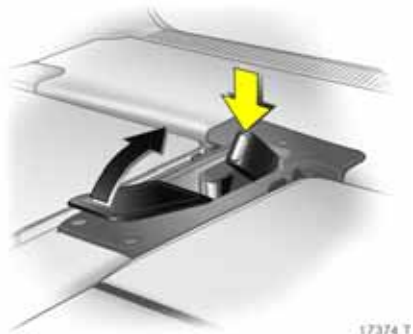

17374 T

Push belt buckles into recess in floor and close cover.

Move seat bench in second row of seats to required position and engage by pushing lever on right or left-hand side of seat bench forwards – see page 20, Fig. 17367 T.

Fit luggage compartment cover * behind second row of seats – see page 57.

Raising seats in third row – see page 53.

Luggage compartment cover * – see page 57.

Safety net * – see page 58.

Lashing eyes – see page 60.

FlexOrganizer * – see page 60.

Folding down backrests of outboard seats in second row



17368 T

Remove luggage compartment cover * if necessary – see page 57.

Press side knob and slide down head restraints of outboard seats in second row.

Place seat belt buckles in pockets in seat bench.

Push down release lever at one or both backrests, then move backrests to a vertical position or tilt forwards or fold flat onto seat cushion and engage.

To move upright, push release lever down and latch backrest in required position.

Folding down centre backrest in second seat row

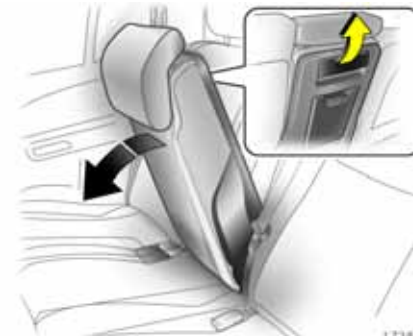

17368 T

Push centre head restraint down as far as possible, pressing catches to release.

Place seat belt buckles in pockets in seat bench.

Pull upper handle on rear of centre backrest, move backrest to a vertical position or fold flat on to seat cushion and engage.

To move seat upright, pull front handle of folded-over backrest, move upright and engage in required position.

Lower second row and push forwards

Remove luggage compartment cover * if necessary – see page 57.

Slide head restraints down by pushing knobs at side and releasing catches.

Place seat belt buckles in seat bench pockets.



17389 T

Raise seat cushion in second row by pushing handle 1 on right or left hand side of seat bench down and pushing up seat bench until it locks into position.

Push down release lever 2 at both outboard backrests, raise backrests and latch into position.

Pull top handle on back of centre backrest, move backrest to vertical position and latch into position.

Push down lever 3 to right or left of seat bench, move seat bench as far forwards as possible and latch into position.

To move upright, press lever 3 and slide seat bench to required position. Adjust backrest angles and swivel seat cushion down using lever 1. All positions must audibly latch.

Folding down the front passenger's seat *



S 11569

Press knob at side and slide front passenger's seat head restraint downwards.

Push front passenger's seat backwards.

Fold front passenger's seat forwards by raising release lever and latch into position.

Straighten front passenger's seat backrest *

Raise release lever and allow front passenger's seat backrest to engage audibly.

Notes on loading –
see page 62.

Luggage compartment cover *

Do not place any heavy or sharp-edged objects on the cover.

Before operating the luggage compartment cover, the rear seat belts must be fed through the side belt holders, see Fig. 17390 T.

Secure unhooked hooks * of seat belts of third row of seats to side holder magnets – see page 67, Fig. 17399 T.

To close:

Pull the cover towards the rear using the handle and engage it in the retainers at the sides.

To open:

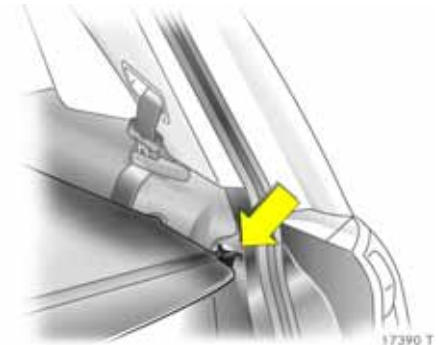

17390 T

Remove luggage compartment cover from side brackets. It rolls up automatically.

Removing

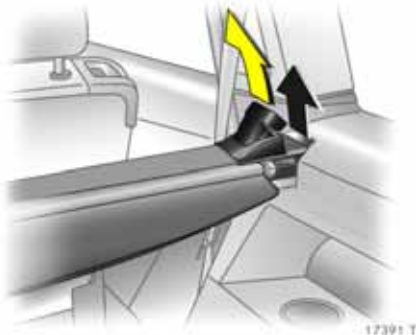

Open the luggage compartment cover.
Move release lever on right side of luggage compartment cover upward. Lift right cover and remove from brackets.

Fitting

Insert luggage compartment cover in aperture, pull release lever at right side upwards, insert right luggage compartment cover and engage.

Stowage in front of tailgate

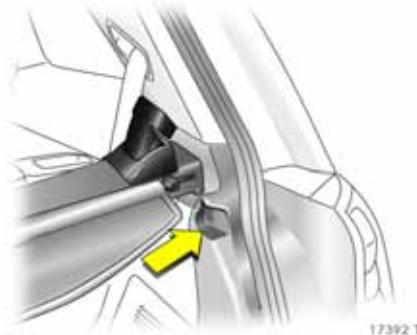

With the third row of seats up right, stow luggage compartment cover in rear position: insert left luggage compartment cover into aperture, fold release lever at right-hand side upwards, insert and engage right luggage compartment cover.

Safety net *

The safety net can be fitted behind the second row of seats or, if the seats in the second row are folded, behind the front seats.

Passengers must not be transported behind the safety net.

Fitting



There are two installation openings in the roof frame: suspend and engage rod of net at one side, compress rod and suspend and engage at other side.

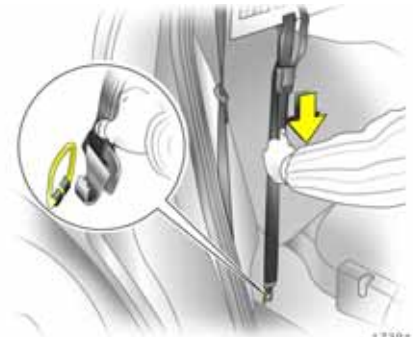

Suspend hooks of net tensioning belts in lashing eyes in floor behind the second row of seats and tension,
– or –

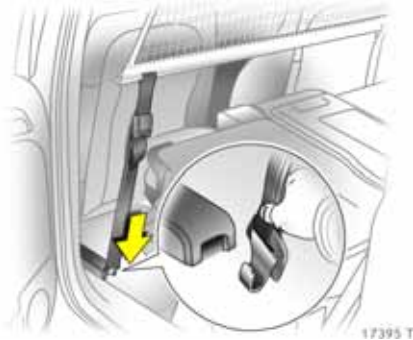

17395 T

Suspend hooks of net tensioning belts in slots behind front seats and tension.

Removing

Raise length adjuster of the net tensioning belt and move belt to one side. Compress the upper net rod and remove from the fitting openings.

Storage of safety net

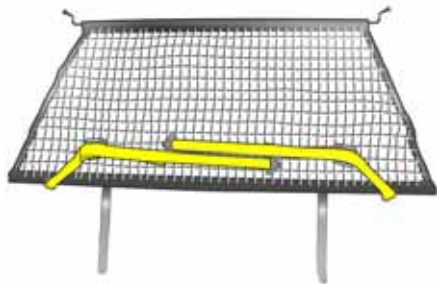

18486 T

Remove safety net. Place tensioning straps as shown in illustration and align to net.

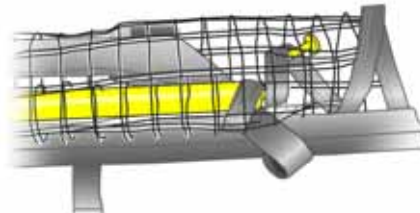

18487 T

Roll the upper net rod down to approximately over the middle.

Place the upper net rod over the tensioning straps next to the lower net rod. The hooks on the upper net rod must point away from the lower net rod.



18488 T

Fasten Velcro tape tightly about the net next to the length adjusters. The length adjusters and net rods must lie flat next to each other, see illustration.

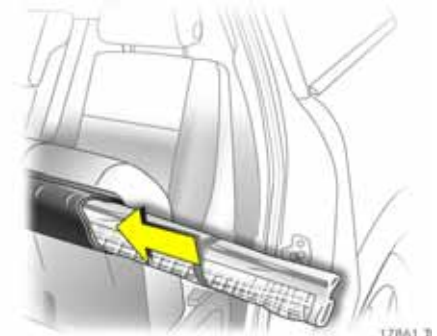

17861 T

Push down lower lever to right or left of seat bench to raise seat bench of second row of seats – see page 56. Slide safety net into receptacle beneath seat bench, fold seat bench downwards and engage.

Lashing eyes *

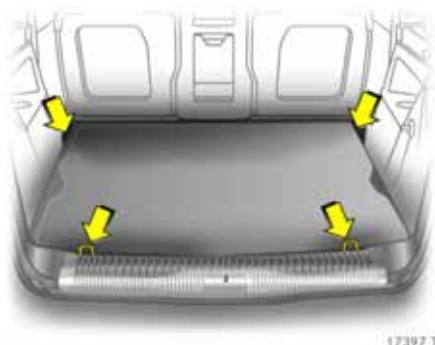

17397 T

Lashing eyes in the luggage compartment serve to secure items being transported against slippage, e.g. using lashing straps *, a luggage net * or safety net *.

In version with FlexOrganizer * the eyes for securing the removable seat belts must not be used as lashing eyes.

The seat belts in the third row of seats must never be used for securing loads.

Rails * and hooks * in luggage compartment



17398 T

The side walls of the luggage compartment house two rails. Insert the hooks in the desired position in the rails: insert the hook in the upper groove on the rail and press in the lower groove.

Pull off the hook to remove.

When the FlexOrganizer rails and components * are being used (with the exception of the partitioning net in front of the tailgate) – see page 61, the seats in the third row must be folded in – see page 55, and the seat belts must be unhooked from the floor – see page 67, Fig. 17420 T.

Secure released seat belt hooks to belt holder magnets – see page 67, Fig. 17399 T.

FlexOrganizer *

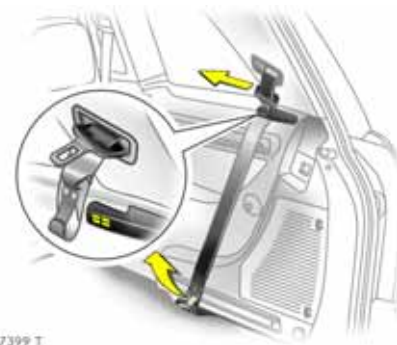

17399 T

Flexible system for dividing the luggage compartment or securing the load.

When the FlexOrganizer components are being used (with the exception of the partitioning net in front of the tailgate), the seats in the third row must be folded in – see page 55, and the seat belts must be unhooked from the floor – see page 67, Fig. 17420 T. Secure released seat belt hooks to belt holder magnets, see Fig. 17399 T.

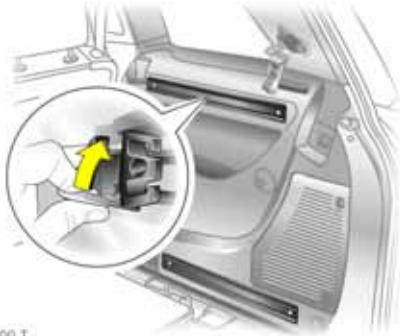

17400 T

The system consists of

- adapters
- variable partition net
- mesh pockets for the side walls
- hooks in the luggage compartment

The components are fitted in two guide rails in the side panels of the luggage compartment using adapters and hooks. The partitioning net can also be fitted in the frame in front of the tailgate.

Variable partition net



17401 T

Insert an adapter into each rail: fold open the handle plate, insert adapter into upper and lower groove of rail and move to required position. Swivel handle plate upwards to lock the adapter. The rods of the net must be extended before inserting into the adapters: pull out each of the four end pieces and lock by rotating clockwise.

To install, push rods together a little and insert into the relevant openings in the adapters. The longer rod must be inserted into the upper adapter.

Luggage hooks and net pocket



17402 T

Insert luggage hooks into required position in rails: to do this, insert hooks in upper groove of rail and push into lower groove. Net pocket can be suspended from the luggage hooks.

Partitioning net in front of tailgate

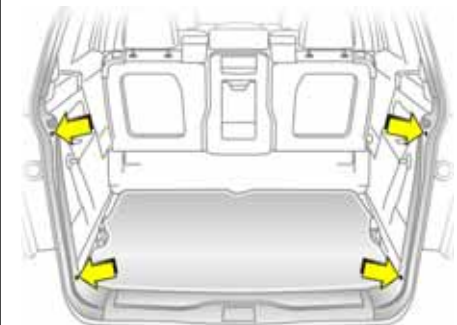

17403 T

The partitioning net can be fitted in the recesses in the panel in front of the tailgate with the third row of seats upright. This prevents the load from falling out when the tailgate is opened.

The four rod end pieces of the net must be pushed in before installation by rotating each end piece anticlockwise and pushing in.

To install, push rods of partitioning net together a little and insert into the relevant openings in the panel. The longer rod must be inserted at the top.

For easier loading with the third row of seats upright, first insert the rod, load the luggage compartment and then insert the upper rod.

Removing

Push rod of partitioning net together and remove from the adapters and the recesses in the panel.

Adapter: fold open the retainer, release the adapter from the lower groove and remove from the upper groove.

Disengage luggage hook from the rails.

Floor covering * in luggage compartment

When the third row of seats is not in use and are –folded away– a cover can be placed over the luggage compartment floor.

Notes on loading the vehicle

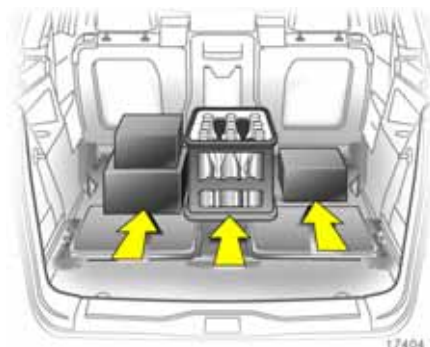

- Heavy objects in the luggage compartment should be placed against the engaged rear seat backrests or, if the rear seat backrests are folded down, against the front seat backrests. If objects are to be stacked, the heavier objects should be placed at the bottom. Unsecured objects in the luggage compartment would be thrown forwards with great force in the event of heavy braking, for example.
- Secure heavy objects with lashing straps * attached to lashing eyes – see page 60. If heavy loads slip when the vehicle is braked heavily or driven around a bend, the handling of the vehicle may change.
- Secure loose articles in luggage compartment using FlexOrganizer * or luggage net * to prevent sliding.
- When transporting objects in the luggage compartment, fit safety net * – see page 58.
- Close the luggage compartment cover * to prevent the objects from being reflected in the rear window.
- If the backrests are not folded down when transporting objects in the luggage compartment, they must be engaged in their upright position – see page 56.
- Do not allow the load to protrude above the upper edge of the backrests of the seats in the second row or, if the second row seats have been removed, above the upper edge of the front seat backrests.
- The warning triangle * and first-aid kit (cushion) * must always be freely accessible.
- Do not place any objects on the luggage compartment cover * and on the instrument panel. They are reflected in the glass, obstruct the driver's view and will be thrown through the vehicle in the event of hard braking, for example.
- Objects must not be stored in the airbag inflation area, because they could cause injury if the airbag system is triggered.
- The load must not obstruct the operation of the pedals, handbrake and gear selector, or hinder the freedom of movement of the driver. Do not place any unsecured objects in the interior.

- Do not drive with luggage compartment open when transporting bulky objects, for example, since toxic exhaust fumes could penetrate the interior.
- Weights, payload and roof load – see page 217.
- Driving with a roof load increases the sensitivity of the vehicle to crosswinds and has a detrimental effect on vehicle handling due to the vehicle's higher centre of gravity. For driving with a roof load – see pages 142, 144, 164.

⚠ Warning

Disregard of these instructions may lead to injuries or end anger life. Vehicle passengers must be informed accordingly.

Three-stage restraint system

Comprising:

- Three-point seat belts,
- Belt tensioners at the front seats,
- Airbag systems for driver's seat, front passenger's seat and the outboard seats of the second row of seats ✱.

The three stages are activated in sequence depending on the seriousness of the accident:

- The automatic seat belt locking devices prevent the belt strap from being pulled out and thus ensure that the vehicle occupants are retained in their seats.

- The front seat belts are pulled down at the belt buckles. This means the belts fit snugly, the occupants are decelerated early with the vehicle and the body loading is reduced.
- The airbag systems are also triggered in the event of serious accidents and form a safety cushion for the occupants. Depending on the severity of the accident, the front airbags inflate in two stages.

⚠ Warning

The airbag systems serve to supplement the three-point seat belts and belt tensioners. The seat belts must therefore always be worn. Disregard of these instructions may lead to injuries or end anger life. Vehicle passengers must be informed accordingly.

Read the instructions supplied with the child restraint system!

Three-point seat belts



The vehicle is equipped with three-point seat belts with automatic retractors and locking devices, allowing freedom of body movement although the spring tensioned belts always ensure a snug fit.

For information on correct seating position – see pages 50, 65, 70.



The belts are locked during heavy acceleration or deceleration of the vehicle.

⚠ Warning

Always wear your seat belt, and that means also in urban traffic and when you are a rear seat passenger. It can save your life!

Also, pregnant women must always wear a seat belt – see page 65.

In the event of an accident, persons not wearing seat belts endanger their fellow occupants and themselves.

Control indicator   for the seat belt – see page 84.

Seat belts are only designed for use by one person at a time. They are not suitable for persons younger than 12 years of age or smaller than 150 cm.

For children up to 12 years of age, we recommend the Vauxhall child restraint system – see page 68.

Belt force limiters

Belt force limiters on the front seats reduce the body load due to damped release of the belt on a collision. This means that the occupants move forwards under control.

Inspection of belts

Check all parts of the belt system occasionally for damage and function. Replace damaged parts. Following an accident, have the belts and deployed belt tensioners replaced by a workshop.

Do not perform any alterations on the belts, their anchorages, the automatic retractors or the belt buckles.

Make sure that belts are not damaged or trapped by sharp-edged objects.

Belt tensioners

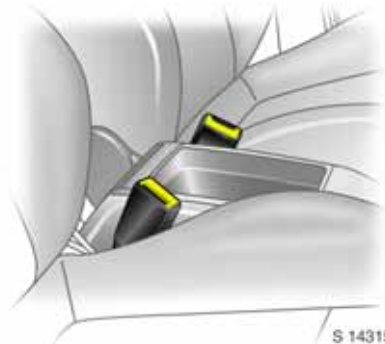

The front seat belts are fitted with belt tensioners. The seat belts are pulled down at the buckles on a front or rear-impact above a certain severity. This tightens the belts.

Actuation of belt tensioners

Actuation of belt tensioners is indicated by illumination of control indicator , see Fig. 17105 T.

If the belt tensioners are deployed, these must be replaced by a workshop.

Further information – see page 65.

Control indicator  for belt tensioners



The function of the belt tensioners is monitored electronically together with the airbag systems and indicated by control indicator . When the ignition is switched on, the control indicator illuminates for approx. 4 seconds. If it does not illuminate, does not go out after 4 seconds or illuminates whilst driving, there is a fault in the belt tensioner or an airbag systems. The systems may fail to trigger in the event of an accident.

Deployment of the belt tensioners is indicated by continuous illumination of .

 Warning
Immediately rectify the cause of the fault.

Self-diagnosis integrated into the system facilitates rapid rectification of faults.

Important

- Accessories and other objects not specifically approved for your vehicle type must not be affixed or placed within the action zone of the belt tensioners (near the belt buckles) as this could result in injury if the belt tensioners are triggered.
- Do not make any modifications to the components of the belt tensioners, as this will render the vehicle unroadworthy.

⚠ Warning
Incorrect handling (e.g. removal or fitting of belts or belt buckles) can trigger the belt tensioners with risk of injury.

- The belt tensioner and airbag system control electronics can be found in the centre console area. In order to avoid malfunctions, do not store magnetic objects in this area.
- When using the rear seats, ensure that the front belt components are not damaged by shoes or other objects. Avoid dirt getting into the retractors.
- We recommend that you have the front seats removed by a workshop in the event of a ctuation of the belt tensioners.
- The belt tensioners are deployed once only, indicated by illumination of . Deployed belt tensioners must be replaced by a workshop.

- When disposing of the vehicle, the safety regulations applicable to this must be observed. Have the vehicle disposed of by a company which reuses vehicle parts.

**Using the belts
Fitting the belt**



Pull the belt out of the retractor and guide it a cross the body, making certain that it is not twisted.

Insert the latch plate into the buckle. The front seat backrest must not be tilted back too far or the seat belt will not operate properly. The recommended maximum angle of inclination is 25°. Make sure that the lap belt is not twisted and that it fits snugly across the body. Tension the belt frequently whilst driving by tugging the diagonal part of the belt.

⚠ Warning
On pregnant women in particular, the lap belt must be positioned as low as possible across the pelvis so as not to put too much pressure on the abdomen.



Thick layers of clothing prevent the belt from fitting snugly. The belt must not rest against hard or fragile objects in the pockets of your clothing (e.g. ballpoint pen, keys, spectacles), since this could cause injury. No objects such as handbags, mobile phones etc. must be present between the belt and your body.

Height adjustment

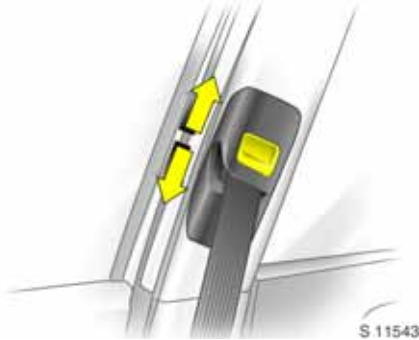

Height adjustment of the upper anchorage point of the front belt and outboard belts in the second seat row:

1. Pull belt out slightly.
2. Press down button on adjuster slide.
3. Move adjuster slide up or down.
4. Allow sliding adjuster to audibly latch.

Do not adjust height whilst driving.



Adjust height such that the belt passes over the wearer's shoulder and rests against the shoulder. It must not pass over the neck or upper arm.

Removing the belt



To remove the belt, depress the red push button on the buckle; the belt will retract automatically.

Seat belts in the second row

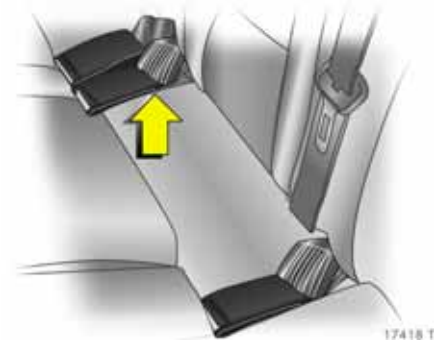

When adjusting second seat row to enlarge luggage compartment, place seat belt buckles in pockets in seat bench as shown in illustration.

The seat belt for the centre seat can only be pulled out of the inertia reel if the backrest is latched in the rearmost position.

Seat belts in the third row

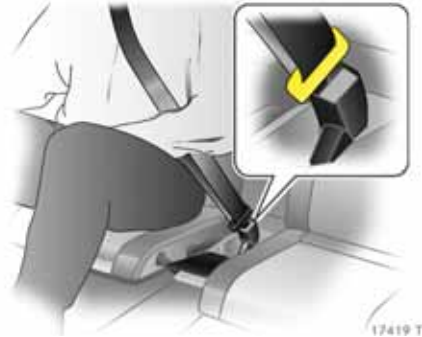

17419 T

Open the cover in the floor between the seats and pull up the belt buckles.

Remove latch plate and seat belt from belt holder.

⚠ Warning

The belt must not be routed through the belt holder when the seat belt is being worn.



17370 T

When not in use, route the seat belt through the belt holder as shown in the illustration, and insert the latch plate into the holder.



17399 T

Unhookable seat belts ✳ in the third row

To make better use of the rails and Flex Organizer components ✳ in the luggage compartment, the seat belts in the third row of seats may be removed from the seat belt eyes on the floor of the vehicle when the seats are folded down.



17420 T

To do this, press spring-loaded tab and unhook hooks from the seat belt eyes on the floor of the vehicle. Reel up the seat belt and attach hooks to magnet of seat belt holder, see Fig. 17399 T.

To reinstall the seat belt, remove hook from magnetic holder, push spring-loaded tab at hook and fit seat belt eye in floor of vehicle. The seat belt must not be twisted and the hook must be properly engaged in the seat belt eye with the spring-loaded tab closed again.

To move the seat belts for the third row of seats as shown in Fig. 17370 T on page 67, feed through a belt holder and insert latch plate in bracket.

Warning

Before moving the third row of seats upright, all components must be removed from the rails in the luggage compartment and the seat belts suspended in the seat belt eyes in the floor of the vehicle without twisting.

The belt must not be routed through the belt holder when the seat belt is being worn.

Important

- Unhookable seat belts in the third row of seats are identified by a marker label on the belt.
- When the seat belt is being worn, the seat belt hook must be installed in the eye in the floor of the vehicle and the seat belt must not be led through the seat belt holder.
- The unhooked seat belts in the third row of seats may only be attached to the provided eyes in the floor of the vehicle – see page 67, Fig. 17420 T.
- The eyes and the seat belts of the third row of seats may not be used for lashing loads.
- There must be no objects in the seat belt hooks.

Child restraint systems *

When using a child restraint system, note the instructions for installation and use.

The country in which you are travelling may not permit the use of child restraint systems on certain seats. Always comply with the local or national regulations.

Selecting the right system

Your child should travel facing backwards in the vehicle for as long as possible. A child has a very weak cervical spinal column and in the event of an accident is less likely to suffer injury in a rearward-facing, semi-lying position than if seated upright.

Permitted options for child restraint mounting – see page 228.

Warning

Never carry child restraint systems on your lap, risk of fatal injury.

Note

- Children under 12 years or under 150 cm tall should only travel in an appropriate child safety seat.
- When transporting children, use the child restraint systems suitable for the child's weight.
- Ensure correct installation of child restraint system, see the instructions enclosed with the system.
- The covers of the Vauxhall child restraint system can be wiped clean.

- Do not stick anything on the child restraint systems and do not cover them with any other materials.
- Only allow the child to enter and exit on the side of the vehicle facing away from the road.
- A child restraint system which has been subjected to stress in an accident must be replaced.
- Secure or remove child restraint systems carried in the vehicle when not in use.

Mounting brackets * for ISO-FIX child restraint systems

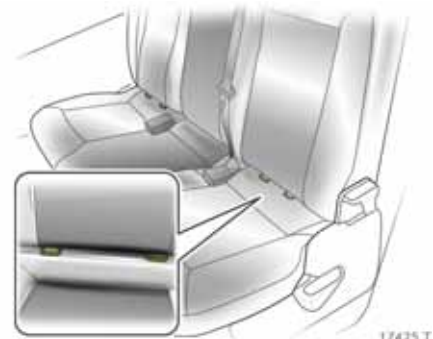

The brackets located between the backrest and seat cushion are used for mounting ISO-FIX child restraint systems.

The instructions accompanying the ISO-FIX child restraint system are to be expressly followed.

Only ISO-FIX child restraint systems permitted for the vehicle may be used.

Fastening eyes ✱ for Top-Tether child restraint systems

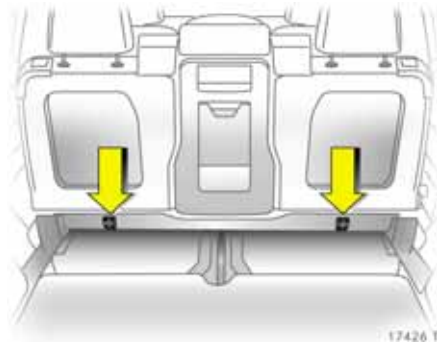

There are two eyes for central attachment of Top-Tether child restraint systems in the crossmember behind the outboard backrests of the second row of seats.

The strap of the Top-Tether child restraint system must run below the head restraint between the two guide rods.

Please be sure to follow the instructions provided with the Top-Tether child restraint system.

When using ISO-FIX and Top-Tether for seat mounting, universally permitted child restraint systems for ISO-FIX may be used.

Airbag system



Front airbag

The front airbag system is identified by the word **AIRBAG** on the steering wheel and above the glove compartment.

The front airbag system comprises:

- an airbag with inflator in the steering wheel and a second one behind the trim panel above the glove compartment,
- control electronics with impact sensors,
- control indicator for airbag systems ✱ in instrument cluster,
- seat occupancy recognition ✱,
- the control indicator for Vauxhall child restraint systems ✱ with transponders ✱ in the instrument cluster.

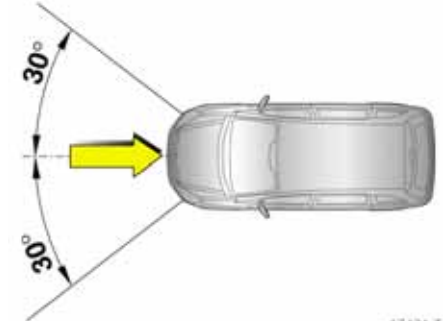

The front airbag system is triggered:

- depending on the severity of the accident,
- depending on the type of impact,
- within the range shown in the illustration,
- independent of side airbag ✱ and curtain airbag system ✱.

Exception:

Front passenger's seat with seat occupancy recognition system ✱. The seat occupancy recognition system deactivates the front and side airbags ✱ on the passenger's side if the front passenger's seat is unoccupied or a Vauxhall child restraint system with transponders ✱ has been fitted to the front passenger's seat.

For seat occupancy recognition – see page 74. For Vauxhall child restraint system with transponders ✱ – see page 77.

Examples of events triggering the front airbag system:

- Impact against a non-yielding obstacle: the front airbags are triggered at low vehicle speed.
- Impact against a yielding obstacle (such as another vehicle): the front airbags are only triggered at a higher vehicle speed.

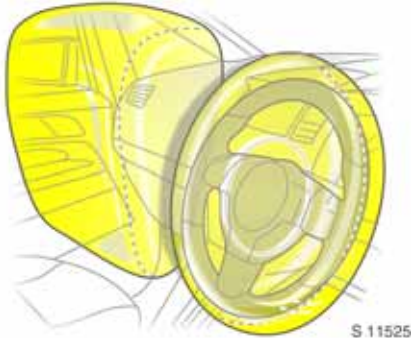

S 11525

When triggered, the front airbags inflate in milliseconds to form a safety cushion for the driver and front passenger. The forward movement of the front seat occupants is checked, thereby substantially reducing the risk of injury to the upper body and head. No impairment of view will occur, because the airbags inflate and deflate so quickly.



S 11536

⚠ Warning

The front airbag system provides optimum protection when the seat, backrest and head restraint are correctly adjusted: Adjust the driver's seat according to the occupant's height such that with the driver sitting upright the steering wheel is held in the area of its upper spokes with the driver's arms slightly bent. The front passenger's seat should be as far back as possible, with the backrest upright – see pages 3, 49, 50. Do not place the head, body, hands or feet on the covers of the airbag systems.

Do not place any objects in the area in which the airbags inflate. Important information – see page 75.



S 11517

⚠ Warning

The three-point seat belt must be correctly fitted – see page 65.

The front airbag system will not be triggered in the event of

- the ignition being switched off,
- minor frontal collisions,
- accidents in which the vehicle overturns,
- collisions involving a side or rear-impact,

that is to say, if it would not be of benefit to the occupants.

⚠Warning

Seat belts must always be worn. The front airbag system serves to supplement the three-point seat belts. If you do not wear your seat belt you risk being seriously injured, or even thrown from the vehicle, in the event of an accident.

If an accident occurs the belt helps to maintain the correct seat position that is required for the front airbag system to provide you with effective protection.

In addition, the front airbag system will not be triggered for the front passenger's seat in versions with seat occupancy recognition * if

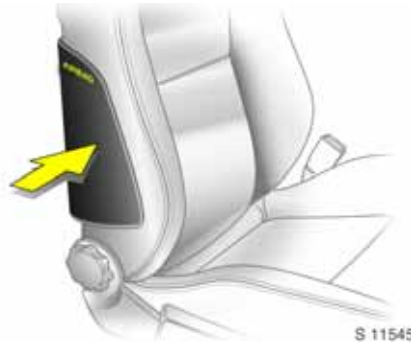

- the front passenger's seat is unoccupied,
- there is a properly fitted Vauxhall child restraint system with transponders. For seat occupancy recognition – see page 74. For Vauxhall child restraint system with transponders – see page 77.

Side airbags *



The side airbag system is identified by the word **AIRBAG** on the outward sides of the front seat backrests.

The side airbag system comprises:

- an airbag with inflator in the back of the driver's and front passenger's seat respectively,
- the control electronics,
- the side-impact sensors,
- control indicator for airbag systems  in instrument cluster,
- seat occupancy recognition *,
- the control indicator for Vauxhall child restraint systems  with transponders * in the instrument cluster.

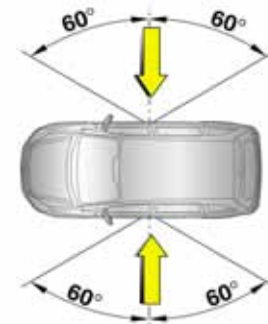

17422 T

The side airbag system is triggered:

- depending on the severity of the accident,
- depending on the type of impact,
- within the range shown in the illustration on the centre door pillar of the driver's or front passenger's side,
- independently of the front airbag system.

Exception:

Front passenger's seat with seat occupancy recognition system ✱. The seat occupancy recognition system deactivates the front and side airbags ✱ on the front passenger's side if the front passenger's seat is unoccupied or a Vauxhall child restraint system with transponders has been fitted to the front passenger's seat. For seat occupancy recognition – see page 74. For Vauxhall child restraint system with transponders – see page 77.

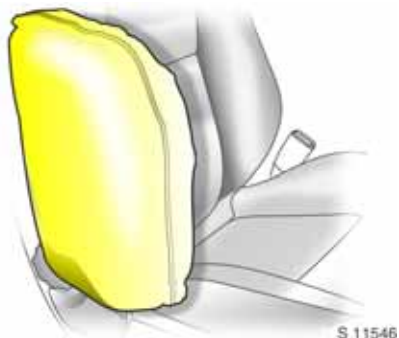

When triggered, the side airbag inflates within milliseconds to form a safety cushion for the driver or front passenger in the respective door area. This substantially reduces the risk of injury to the upper body and pelvis in the event of a side-on collision.

Warning

There must be no objects in the area in which the airbag inflates or in the area between the seat backs and the vehicle body. Do not place the hands or arms on the covers of the airbag systems. Important information – see page 75.

The three-point seat belt must always be correctly fitted – see page 65.

The side airbags will not be triggered in the event of

- the ignition being switched off,
- frontal collisions,
- accidents in which the vehicle overturns,
- collisions involving a rear-impact,
- Side-on collisions outside the passenger cell.

In addition, the side airbag system ✱ will not be triggered for the front passenger's seat in versions with seat occupancy recognition ✱ if

- the front passenger's seat is unoccupied,
- there is a properly fitted Vauxhall child restraint system with transponders. For seat occupancy recognition – see page 74. For Vauxhall child restraint system with transponders – see page 77.

Curtain airbag ✱



The curtain airbag system is identified by the word **AIRBAG** on the roof pillar trim.

The curtain airbag system comprises:

- an airbag with inflator in the roof frame on the driver's and front passenger's side respectively,
- the control electronics,
- the side-impact sensors,
- control indicator for airbag systems ✱ in instrument cluster.

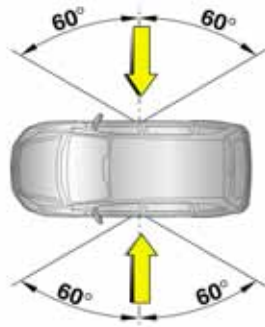

17422 T

The curtain airbag system is triggered:

- depending on the severity of the accident,
- depending on the type of impact,
- within the range shown in the illustration on the centre door pillar of the driver's or front passenger's side,
- together with the side airbag system ✱,
- irrespective of seat occupancy recognition ✱,
- independently of the front airbag system.

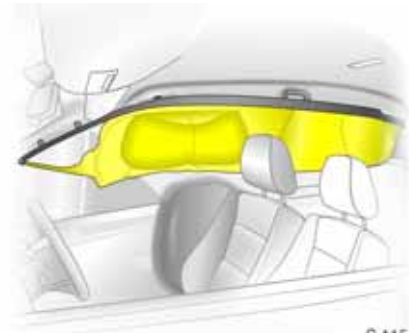

S 11548

When the curtain airbag is triggered it inflates within milliseconds and provides a safety barrier in the head area on the respective side of the vehicle. This reduces the risk of injury to the head considerably in case of a side-impact.

The curtain airbag system does not protect persons in the seats in the third row of seats.

Warning

There must be no objects in the area in which the airbag inflates or in the area between the seat backs and the vehicle body. Do not place the hands or arms on the covers of the airbag systems. Important information – see page 75.

The three-point seat belt must always be correctly fitted – see page 65.

The curtain airbags will not be triggered in the event of

- the ignition being switched off,
- frontal collisions,
- accidents in which the vehicle overturns,
- collisions involving a rear-impact,
- Side-on collisions outside the passenger cell.

Control indicator for airbag systems



17105 T

The function of the airbag systems is monitored electronically together with seat occupancy recognition ✱ and the belt tensioners and shown by control indicator . When the ignition is switched on, the control indicator illuminates for approx. 4 seconds. If it does not illuminate, does not go out after 4 seconds or illuminates whilst driving, there is a fault in the airbag systems, seat occupancy

recognition * or the belt tensioners – see also page 64. The systems may fail to trigger in the event of an accident.

Deployment of the airbags is indicated by continuous illumination of *

Warning

Have the cause of the fault rectified immediately by a workshop.

Self-diagnosis integrated into the system permits rapid rectification of faults.

Seat occupancy recognition *

The seat occupancy recognition system deactivates the front and side airbags * for the front passenger's seat if the front passenger seat is not occupied or a Vauxhall child restraint system with transponders * is fitted on the front passenger's seat. The curtain airbag system * remains activated.

The control indicator for seat occupancy recognition * appears in the instrument cluster. If the control indicator * illuminates for approx. 4 seconds once the ignition is switched on, the vehicle is fitted with seat occupancy recognition, see Fig. 17117 T on the next page.

If a Vauxhall child restraint system with transponders * is fitted, the control indicator * illuminates permanently after switching on the ignition as soon as the system has detected the child restraint

system. Only then may a child restraint system with transponders * be fitted on the front passenger's seat.



17116 T

Vehicles with seat occupancy recognition are also identified by a sticker on the lower panel of the front passenger's seat – see illustration above.

Vauxhall child restraint systems with transponders * are automatically detected if correctly fitted to the front passenger's seat. When these child restraint systems are being used on the front passenger's seat, the front and side airbag systems for the front passenger's seat are deactivated. The curtain airbag

system remains activated. Pay attention to the control indicator * for seat occupancy recognition *.

Warning

Only Vauxhall child restraint systems with transponders * can be fitted on the front passenger's seat. Use of systems without transponders poses a risk of fatal injury.

Vauxhall child restraint systems with transponders * are identified by a sticker or label.

Control indicator * for Vauxhall child restraint systems with transponders *

The presence of a Vauxhall child restraint system with transponders * is indicated by the continuous illumination of control indicator * in the instrument cluster once the ignition has been switched on and the seat occupancy recognition system has detected the child restraint system.



If the control indicator does not come on whilst driving, the front and side airbags * for the front passenger's seat are not deactivated, and the life of the child may be endangered. Fit child restraint system on the rear seat. Have the cause of the fault rectified by a workshop.

If the child restraint system is not correctly installed or the transponder is faulty, the control indicator flashes. Check for correct installation of child restraint system.

To install the child restraint system with transponders * – see the instructions enclosed with the system.

If the control indicator for Vauxhall child restraint systems with transponders * flashes when the child restraint system is fitted correctly, there is a risk to the child. Fit child restraint system on the rear seat. Have the cause of the fault rectified by a workshop.

If no Vauxhall child restraint systems with transponders * are fitted, the control indicator must not come on or flash as the airbag systems for the front passenger's seat would not be triggered. Have the cause of the fault rectified by a workshop.

Warning

If the Vauxhall child restraint system with transponders * has been fitted according to the instructions, the control indicator for Vauxhall child restraint systems with transponders must illuminate in the instrument cluster when the ignition is switched on.

If the control indicator does not come on whilst driving, the airbag systems for the front passenger's seat are not deactivated, risk of fatal injury. Fit child restraint system on the rear seat. Have the cause of the fault rectified by a workshop.

Important

- Accessories and other objects must not be affixed or placed in the area in which the airbags inflate as they could cause injury if the airbags are triggered.
- Do not place any objects between the airbag systems and the vehicle occupants; risk of injury.

Warning

Never carry child restraint systems or other objects on your lap, risk of fatal injury.

- Only use the hooks * on the handles in the roof frame to hang up light articles of clothing or coat hangers. Do not place any objects in the pockets of the hanging items, risk of injury.
- The airbag systems and belt tensioner control electronics can be found in the centre console area. In order to avoid malfunctions, do not store magnetic objects in this area.
- Do not stick anything on the steering wheel, instrument panel, front seat backrests or roof frame, in the vicinity of the airbags, or on the front passenger's seat cushion, or cover any of those areas with other materials.

- Use only a dry cloth or interior cleaner to clean the steering wheel, instrument panel, front seat backrests, roof frame and seat cushion of the front passenger's seat. Do not use any aggressive cleaning agents.
- Only protective covers which are approved for your vehicle with side airbag system may be fitted on the front seats. When fitting the protective covers, make sure that the airbag units on the outside sides of the front seat backrests are not covered.
- The airbag systems are triggered independently of each other depending on the severity of the accident and the type of impact. The side airbag system and the curtain airbag system ✱ are triggered together. See page 74 for exceptions.
- Each airbag is triggered once only. Have deployed airbags replaced immediately by a workshop.
- The speeds, directions of movement and deformation properties of the vehicles, and the properties of the obstacle concerned, determine the severity of the accident and triggering of the airbags. The degree of damage to your vehicle and the resulting repair costs alone are not indicative that the criteria for triggering of the airbags were met.
- Do not modify airbag system components, since this would render the vehicle unroadworthy.

Warning

If handled improperly the airbag systems can be triggered in an explosive manner – risk of injury!

- We recommend having the steering wheel, the instrument panel, all panelling parts, the door seals, the handles and the seats removed by a workshop.
- When disposing of the vehicle, the safety regulations applicable to this must be observed. Have the vehicle disposed of by a company which reuses vehicle parts.
- Persons weighing less than 35 kg should only travel on the rear seats. This does not apply to children who are travelling in child restraint systems with transponders ✱.
- In vehicles with seat occupancy recognition ✱, do not place any heavy objects on the front passenger's seat otherwise the airbag systems for the front passenger's seat may be triggered in the event of an accident.
- In vehicles with seat occupancy recognition ✱, to prevent malfunctions do not use protective covers or extra seat cushions on the front passenger's seat.

Warning

Child restraint systems as well as other objects must never be carried on the lap of passengers; risk of fatal injury. If carried in this way, child restraint systems with transponders ✱ in vehicles with seat occupancy recognition ✱ could lead to front passenger's airbag systems not being triggered in the event of an accident.

- In order to prevent malfunctions when using a Vauxhall child restraint system with transponders ✱ on the front passenger's seat, no objects (e.g. plastic sheet, stickers or heated mats) may be placed under the child restraint system.

Use of child restraint systems * on the front passenger's seat in vehicles with airbag systems, but without seat occupancy recognition *

⚠ Warning

No child restraint system * may be installed on front passenger's seat. Danger to life.



17118 T

Vehicles with front passenger's seat airbag can be identified by the word **AIRBAG** over the glove compartment and the warning sticker on the side of the instrument panel, visible when the passenger's door is open – see Fig. 17118 A.

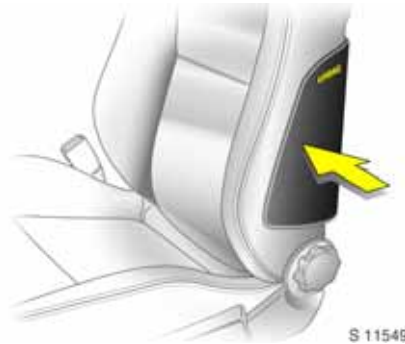

S 11549

The side airbag system * is identified by the word **AIRBAG** on the outboard sides of the front seat backrests.

Seat occupancy recognition * – see page 74.



17116 T

Use of child restraint systems * on front passenger's seat in vehicles with airbag systems and seat occupancy recognition *



⚠ Warning

Only Vauxhall child restraint systems with transponders * can be fitted on the front passenger's seat. Use of systems without transponders poses a risk of fatal injury.

Vehicles with seat occupancy recognition are identified by a sticker on the lower panel of the front passenger's seat – see Fig. 17116 T.



17117 T

Vehicles with seat occupancy recognition can also be identified by control indicator  in the instrument cluster. If control indicator  illuminates for approx. 4 seconds after the ignition is

switched on, the vehicle is equipped with seat occupancy recognition – see page 74.

The seat occupancy recognition system detects Vauxhall child restraint systems with transponders * and deactivates the front and side airbag systems * for the front passenger's seat. The curtain airbag system * remains activated. For seat occupancy recognition – see page 74.



17424 T

Vauxhall child restraint systems with transponders * can be identified by a sticker on the child restraint system, see Fig. 17424 T.

Cigarette lighter *

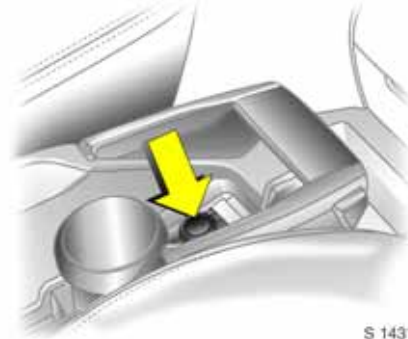

S 14316

There is a cigarette lighter in the console between the front seats.

Press in cigarette lighter. Switches off automatically once the element is glowing. Pull out lighter.

Accessory socket *



17929 T

Accessory sockets can be found in the console between the front seats, the console in front of the second row of seats and on the right in the luggage compartment.

Accessory sockets can be used to connect electrical accessories. The battery is discharged if the engine is stationary.



17407 T

Do not damage the sockets by using unsuitable plugs.

The maximum power consumption of electrical accessories must not exceed 120 watts.

Do not connect any current-delivering accessories, e.g. electrical charging devices or batteries.

Electrical accessories connected to the socket must comply with the electromagnetic compatibility requirements laid down in DIN VDE 40 839, otherwise vehicle malfunctions may occur.

If the tyre repair kit is* is in operation, no consumers may be connected to the auxiliary socket.

Ashtrays*

To be used only for ash and not for combustible rubbish.

Warning

Failure to observe these descriptions can lead to injuries which may be fatal. Vehicle passengers must be informed accordingly.

Ashtray, front

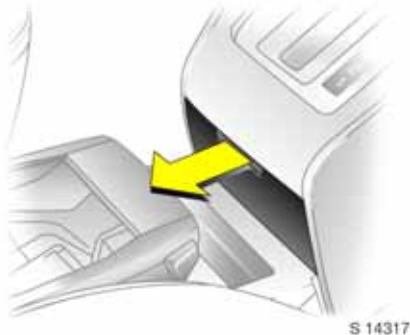

Open ashtray at recess.

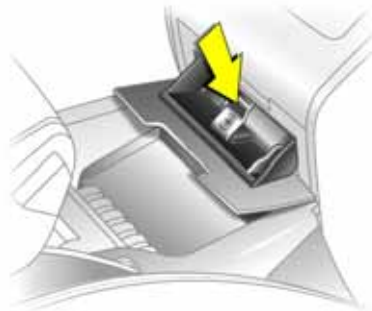

S 14318

To empty the ashtray, press the spring, open ashtray all the way and remove.

Ashtray socket



17410 T

For universal use in the centre console, the door pockets in the inner panelling of all the doors and in the rear side panelling.

Open cover to use.

Foldaway tables*

Located on the front seat backrests.

Open by pulling upward until it engages.

Fold away by pressing down past the resistance point.

Do not place any heavy objects on the table.

Stowage compartments

Stowage compartment* beneath front passenger's seat

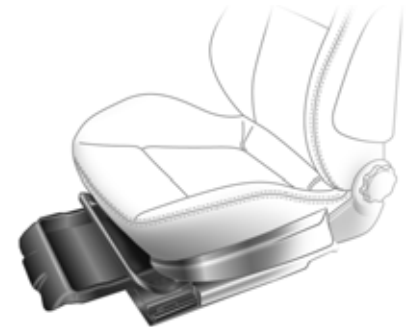

S 11538

Lift stowage compartment by grasping recessed edge and pull out from the front. Maximum load: 1.5 kg. To close the stowage compartment, push it in and engage.

Glove compartment

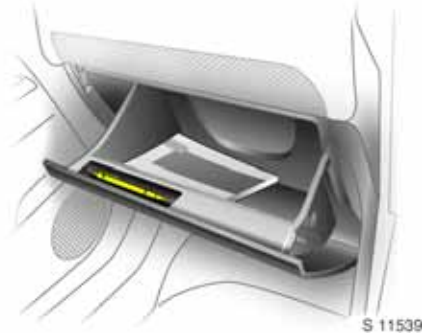

To open, pull handle.

There is a pen holder on the front of the open cover.

The glove compartment should be closed while the vehicle is in motion.

Cooled glove compartment * – see page 117.

Stowage compartment for glasses *

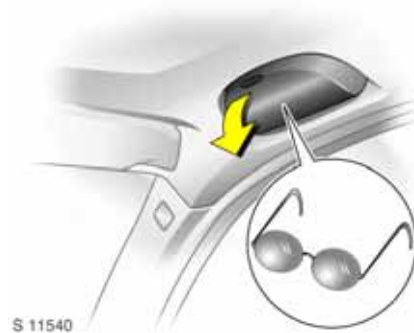

On driver's side: fold down to open.

Do not store heavy objects in the stowage compartment.

Stowage compartments in the roof panningl *



Press marked locations to open.

The maximum permitted load of the two front stowage compartments is 1 kg, and the maximum permitted load of the three stowage compartments in the rear is 2 kg.

The stowage compartments must be closed whilst driving.

Stowage compartments in the luggage compartment

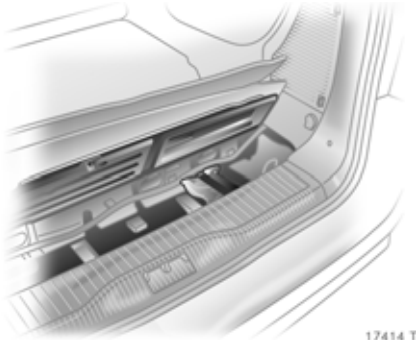

17414 T

The vehicle tools with jack * and towing eye and the trailer coupling ball bar * are stowed beneath a hatch in the vehicle floor at the rear. To open the hatch, lift the carpeting then raise, rotate and lift the ring.

The fusebox is behind the left hatch in the luggage compartment side panelling – see page 184.

The tyre repair kit is on the right-hand side behind the flap * – see page 179.

For first-aid kit (cushion), warning triangle in the luggage compartment – see page 174.

Drink holders *

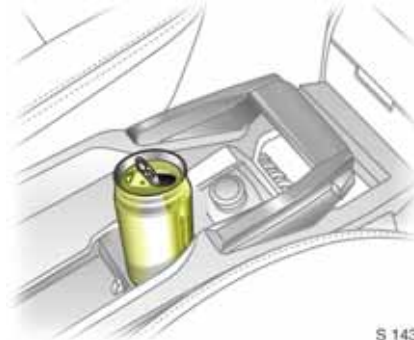

S 14319

Drink holders can be found at the front in the centre console between the front seats, the door pockets in the inner panelling of all the doors and in the rear side panelling.

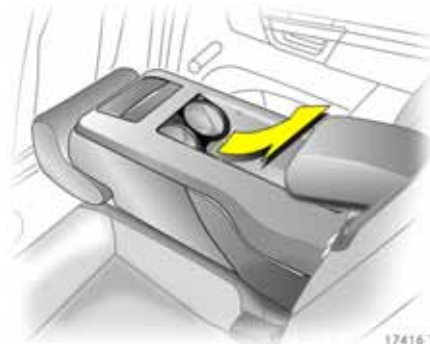

17416 T

More drink holders can be found in the centre backrest in the second seat row in the folded-down position.

Fold centre backrest forwards by pulling handle on rear of centre backrest.

Sunvisors

The sunvisors can be folded down or swivelled to the side to prevent dazzling.

While travelling, the covers for the mirrors in the sunvisors should be closed.

Instruments, Controls

Control indicators



18444 T

The control indicators described here are not present in all vehicles. The descriptions however, apply to all instrument versions.

Control indicators	82
Instrument display	87
Information display	89
Warning buzzers.....	102
Windscreen wiper	102

The control indicator colours mean:

- Red Danger, important reminder,
- Yellow Warning, information, fault,
- Green Confirmation of activation,
- Blue Confirmation of activation.



Open&Start system ✱, fault

Control indicator illuminates or flashes yellow.

If it flashes

System has not detected electronic key in vehicle interior. The reasons for this may be:

- The electronic key is in the wrong location in the vehicle interior (do not put key in luggage compartment or in front of information display), or the electronic key is not in the vehicle interior, or influence from an external interference source (radio masts, interfering transmitters in the vicinity).
- or
- Electronic key failure, for emergency operation – see page 35.

If the battery in the electronic key needs changing, **InSP3** appears in the service display or in vehicles with check control ✱ by an appropriate message in the information display – see page 36.

Illuminated

Fault in Open&Start system. Where necessary, lock or unlock the vehicle with the remote control or emergency key – see page 37, or attempt to activate using the spare key.

Emergency operation – see page 35.

If  illuminates, this can also mean that the steering column lock is still locked: move steering wheel to and fro a little and press Start/Stop button again.

If  illuminates whilst driving a system error has occurred that may eventually lead to a complete failure.

If  illuminates or flashes: The Start/Stop button must be held depressed slightly longer to switch off the ignition. It is possible that the vehicle will not start during the next start attempt.

If  stays on permanently or continues to flash, seek the assistance of a workshop immediately.



Engine oil pressure

Control indicator illuminates red.

It illuminates when the ignition is switched on and goes out shortly after the engine starts.

Illuminates when the engine is running

Engine lubrication may be interrupted. This may result in damage to the engine and/or locking of the drive wheels:

1. Move out of the flow of traffic as quickly as possible without impeding other vehicles.
2. Depress clutch.
3. Shift manual transmission or Easytronic ✱ into neutral; for automatic transmission ✱, set selector lever to **N**.
4. Switch off ignition.

Warning

When the engine is off, considerably more force is needed to brake and steer.

Do not remove key until vehicle has come to a standstill, otherwise the steering column lock could engage unexpectedly.

Check oil level before consulting a workshop.



Brake system, clutch system *

Control indicator illuminates or flashes red.

It illuminates when the ignition is switched on if the handbrake is applied or if the brake or clutch fluid level is too low. Further information – see pages 158, 205.

For vehicles with Easytronic *, the control indicator flashes for a few seconds when the ignition is turned off if the handbrake is not applied.

Warning

Illuminated when the handbrake is off. stop, immediately stop journey. Seek the assistance of a workshop.



Airbag systems *, belt tensioners *

Control indicator illuminates red.

Illuminates when the engine is running

Fault in airbag system or belt tensioners – see pages 64, 73.



Electronic Stability Programme (ESP® Plus) *

Control indicator flashes or illuminates yellow.

Flashing during driving:

System actively engaged – see page 148.

Illuminates whilst driving

The system is off * or there is a fault in the Electronic Stability Programme system – see page 148.



Seat belt *

Control indicator illuminates or flashes red.

Once the ignition is switched on, this stays on until the seat belt is fastened. The control indicator flashes when starting to drive.

Fasten seat belt – see page 63.



Door open

Control indicator illuminates red.

It illuminates when a door or the luggage compartment is open.



Alternator

Control indicator illuminates red.

It illuminates when the ignition is switched on and goes out shortly after the engine starts.

Illuminates when the engine is running

Stop and switch off engine. Battery is not charging. Engine cooling may be interrupted. In diesel engines, power to the brake servo unit may be cut. Check drive belt condition and tensioning before contacting a workshop.



Coolant temperature

Control indicator illuminates red.

Illuminates when the engine is running

Stop and switch off engine. Coolant temperature too high: Danger of engine damage. Check coolant level – see page 204.

**Engine electronics, transmission electronics *, immobiliser, diesel fuel filter *, fault**

Control indicator illuminates or flashes yellow.

It illuminates for a few seconds when the ignition is switched on.

Illuminates when the engine is running

Fault in the engine electronics or transmission electronics system. Electronics switch to emergency running programme, fuel consumption may increase and the drivability of the vehicle may be impaired – see page 147. Immediately seek the assistance of a workshop.

Illuminated together with **InSP4** in the service display: Have the diesel fuel filter drained of water – see page 203.

If it flashes when the ignition is on

Fault in the electronic immobiliser system; the engine cannot be started – see page 30.

**Easytronic *, start engine**

Control indicator illuminates yellow.

It illuminates if the footbrake is not operated. The indicator goes off as soon as the footbrake is operated. The engine can only be started with the footbrake operated – see page 131.

IDS+**Interactive Dynamic Driving System *, Continuous Damping Control (CDC) *, SPORT mode ***

Control indicator illuminates yellow.

It illuminates for a few seconds when the ignition is switched on.

Illuminates whilst driving

Fault in the system. Seek the assistance of a workshop.

IDS+ – see page 148, CDC – see page 150, SPORT mode – see page 150.

**Engine oil level ***

Control indicator illuminates yellow.

The engine oil level is checked¹⁾ automatically.

Illuminates when the engine is running

Engine oil level too low. Check engine oil level and top up engine oil if necessary – see page 202.

¹⁾ Not for Z 20 LEH engine, for sales designation – see page 212.

**Exterior lights**

Control indicator illuminates green.

It is illuminated when the exterior lights are on – see page 105.

**Parking distance sensors ***

Control indicator illuminates yellow.

Fault in the system. Seek the assistance of a workshop.

Parking distance sensors – see page 152.

**Turn signal lights**

Control indicator flashes green.

The corresponding control indicator flashes on the side selected.

Both control indicators flash with the hazard warning lights on.

Fast flashing: failure of a turn signal light or associated fuse, failure of turn signal light on trailer *.

Change bulbs – see page 187.

Fuses – see page 184.

**Fuel level**

Control indicator illuminates or flashes yellow.

Illuminated

Low fuel level, fuel gauge in reserve area.

If it flashes

Fuel supply exhausted, refuel immediately.

Never let the tank run dry!

Erratic fuel supply can cause catalytic converter to overheat – see page 146.

Diesel engines: If the tank is run dry, bleed the fuel system as described on page 170.

**Front fog lights ***

Control indicator illuminates green.

It is illuminated when the front fog lights are on – see page 106.

**Main beam**

Control indicator illuminates blue.

It is illuminated when main beam is on and during headlight flash – see pages 10, 105.

**Fog tail light**

Control indicator illuminates yellow.

It is illuminated when the fog tail lights are on – see page 107.

**Winter programme of automatic transmission * or Easytronic ***

Control indicator is illuminated in transmission display when Winter programme is enabled – see pages 133, 139.

**SPORT mode of automatic transmission * or Easytronic ***

Control indicator is illuminated in transmission display when SPORT mode is enabled – see pages 133, 138.

**Seat occupancy recognition ***

Control indicator illuminates or flashes in odometer display.

Illuminated

Seat occupancy recognition has detected a child restraint system with transponders. Airbag systems for the front passenger's seat are deactivated – see page 74.

If it flashes

Fault in system or child restraint with transponder not correctly fitted – see page 74.

**Exhaust emission ***

Control indicator illuminates or flashes yellow.

It illuminates when the ignition is switched on and goes out shortly after the engine starts.

Illuminates when the engine is running

Fault in the emission control system. The permitted emission limits may be exceeded. Immediately seek the assistance of a workshop.

If it flashes when the engine is running:

Fault which may lead to damage to the catalytic converter – see page 147. Immediately seek the assistance of a workshop.

**Anti-lock Brake System (ABS) ***

Control indicator illuminates red.

Illuminates whilst driving

Fault in Anti-lock Brake System – see page 159.

**Preheating system *, Diesel particle filter ***

Control indicator illuminates or flashes yellow.

Illuminated

Preheating system active, only switches on at low outside temperatures. If it flashes

(in vehicles fitted with a diesel particle filter)

The diesel particle filter must be cleaned. Drive on, and as soon as road and traffic conditions permit, increase your speed to over 25 mph (40 km/h), cleaning of the diesel particle filter is then started. The control indicator goes out as soon as

cleaning is complete. We recommend that you do not switch off the ignition during cleaning.

Further information – see page 148.



Deflation Detection System *,
Tyre Pressure Monitoring System *
Control indicator illuminates red or yellow.

Control indicator illuminates red.
Tyre pressure loss – see page 154.

Control indicator illuminates yellow.
Fault in the system – see pages 154, 156.
Seek the assistance of a workshop.



Adaptive Forward Lighting (AFL) *,
fault

Control indicator illuminates or flashes yellow.

Illuminated
Fault in the system. Seek the assistance of a workshop.

If it flashes
System converted to symmetrical dipped beam.

AFL – see page 108.



Cruise control *
Control indicator illuminates green.

It is illuminated when the system is on – see page 151.

Instrument display

In some versions, the pointers of the tachometer, the speedometer and the fuel gauge briefly rotate to the end position.

Tachometer



Indicates engine speed.

Warning: maximum permitted speed exceeded, engine at risk.

Speedometer



Speed display.

Odometer display



Top line:

Trip odometer

Display of miles / kilometres covered since reset.

To reset, hold the reset knob depressed for a few seconds with the ignition on.

Bottom line:

Odometer

Records the miles / kilometres travelled.

Fuel gauge



Pointer in left zone or illuminated = Reserve area

Pointer in left zone or flashing = Refuel – see page 145

Never run the tank dry!

Diesel engines: If the tank is run dry, bleed the fuel system as described on page 170.

Because of the fuel remaining in the tank, the amount of fuel required to fill the tank may be less than the specified tank capacity.

Service display



InSP Service interval display. Display of the remaining distance to travel until the next Service. For more information – see page 200.

InSP2 Bulb failed * – see page 187.

InSP3 Battery voltage of remote control or electronic key of Open&Start system low * – see pages 33, 36.

InSP4 Water in diesel fuel filter *. Seek the assistance of a workshop.

On vehicles with check control *, a message is shown on the display instead of **InSP2** and **InSP3**.

ESPoff Electronic Stability Programme * off – see page 148.

ESPon Electronic Stability Programme * on – see page 148.

Transmission display *



Display of gear selected on automatic transmission * or current gear or mode for Easytronic *:

- P** Park position of automatic transmission.
- R** Reverse gear.
- N** Neutral.
- A** Automatic mode of Easytronic.
- M** Manual mode of Easytronic.
- D** Automatic mode of automatic transmission.

- 1-4** Current gear of automatic transmission.
- 1-6 *** Manual mode, current gear of automatic transmission.
- 1-5** Manual mode, current gear of Easytronic

For Easytronic *****, the display flashes for a few seconds if **A**, **M** or **R** is selected when the engine is running but the footbrake is not depressed.

Information display Triple Information Display



Display of time, outside temperature and date / Infotainment system (when it is on).

When the ignition is off, the time, date and outside temperature can be presented for 15 seconds by briefly pressing one of the two buttons below the display.

Display **F** in the display indicates a fault. Have the cause rectified by a workshop.

Board Information Display *****



Display of time, outside temperature and date / Infotainment system (when it is on).

Display **F** in the display indicates a fault. Have the cause rectified by a workshop.

Graphical Information Display *****, Colour Information Display *****

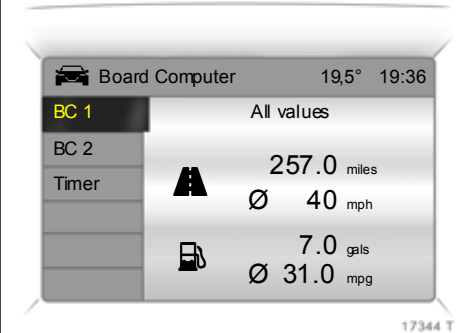

Display of time, outside temperature, date / Infotainment system (when it is on) and Electronic Climate Control (ECC) *****.

The Graphical Information Display presents the information in monochrome. The Colour Information Display presents the information in colour.

The type of information and how it is displayed depends on the equipment of the vehicle and the settings of the trip computer *****, Electronic Climate Control (ECC) ***** and Infotainment system *****.

Some information appears in the display in an abbreviated form.

Electronic Climate Control (ECC) – see page 125. Infotainment system – see Infotainment system instructions.

Display F in the display indicates a fault. Have the cause rectified by a workshop.

Outside temperature



A fall in temperature is indicated immediately and a rise in temperature after a time delay.

If outside temperature drops to 3 °C, the symbol ❄ illuminates in the Triple Information Display or the Board Information Display ❄ as a warning for icy road surfaces. ❄ remains illuminated until temperatures reach at least 5 °C.





In vehicles with Graphical Information Display ❄ or Colour Information Display ❄, a warning message appears the display as a warning for icy road surfaces. There is no message below -5 °C.

Warning



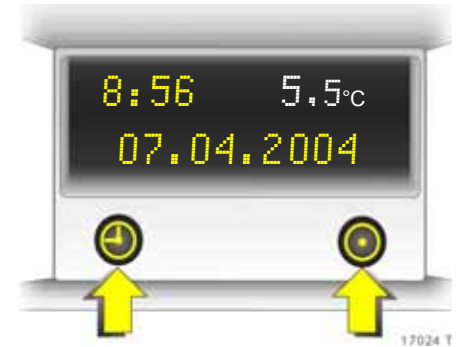



Caution: The road surface may already be icy even though the display indicates a few degrees above 0 °C.

Triple Information Display Set date and time



Infotainment system off: press  and  below the display as follows:



Press  for approx. 2 seconds:

-  Day flashes
-  Set day
-  Set month
-  Set year
-  Set hours
-  Set minutes
-  Clock is started.

Correcting time *



Some RDS transmitters do not send a correct time signal. If the incorrect time is continually displayed, switch off automatic time synchronisation * and set the time manually – see below.

The automatic setting is indicated by  in the display.

Deactivating / activating automatic time synchronisation: Infotainment system off, press  and  below the display:

Hold down  for approx. 2 sec., clock display is now in setting mode.

Press  twice (until year flashes).

Press  and hold down for approx. 3 seconds until  flashes in display * and the text "RDS TIME" appears (years flash during this time).

Press ; display shows:
RDS TIME 0 = Off

Press ; display shows:
RDS TIME 1 = On

Press  three times.

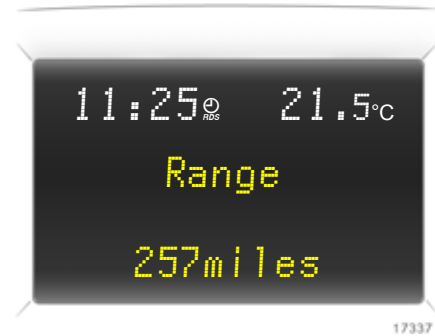
**Board Information Display *,
Selecting functions**

Functions and settings of some equipment * can be accessed via the Board Information Display.

This is done using the menus and buttons in the Infotainment system * or with the left adjuster wheel * on the steering wheel. The corresponding menu options are then shown in the following lines of the display.

If check control warning messages * are displayed, the display is locked for other displays. Confirm warning message. If there is more than one warning message, confirm them one after the other.

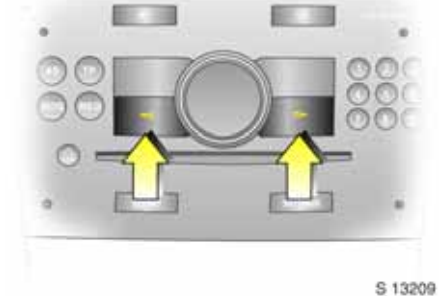
Selection using arrow buttons

Select menu items from the Infotainment system using the buttons.

OK button

Select highlighted point, confirm command.

Selection using the left adjuster wheel * on the steering wheel



Turn up

Previous menu item,

Turn down

Next menu item,

Press

Select highlight, confirm commands.

System settings – see page 92.

Trip computer – see page 93.

Board Information Display *, System settings



Press the **Settings** button on the Infotainment system. Menu item **Audio** or **System** will appear.

Press the left arrow button to access the menu item **System**. Select System menu item. The first function in the menu **System** is highlighted.

The functions are displayed in the following order:

- Time synchronisation
- Time, setting hours
- Time, setting minutes
- Date, setting day
- Date, setting month
- Date, setting year
- Ignition logic
- Language selection
- Setting units of measure

Some information appears in the display in an abbreviated form.

Correcting time *

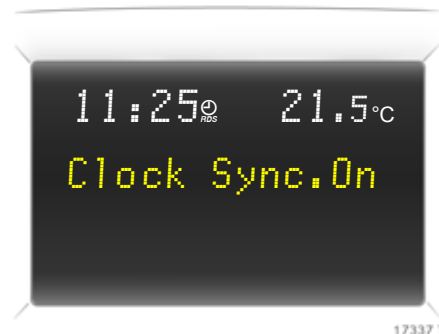

Some RDS transmitters do not send correct time signals. If the incorrect time is displayed often, deactivate automatic time synchronisation * and set the time manually.

The automatic setting is indicated by  in the display.

To correct time with the help of RDS, select the menu item for time synchronisation from the **Settings** menu.

Make the desired setting.

Setting date and time

Select the menu item for time and date setting from the **Settings** menu.

Make the desired setting.

The setting is saved when the menu item is exited.

Ignition logic *

See Infotainment system instructions.

Language selection



You can select the display language for some functions.

Select the menu item for language from the **Settings** menu and make the desired setting.

Setting units of measure

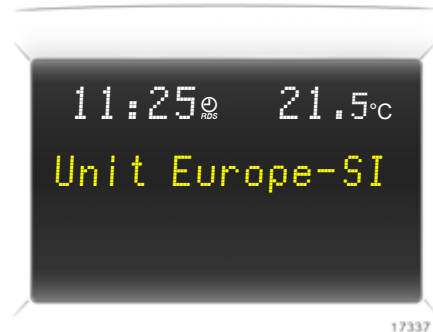

You can select which units of measure are to be used.

Select the menu item for units of measure from the **Settings** menu and confirm the desired setting.

Board Information Display *, trip computer *

The trip computer provides information on driving data, which is continually recorded and evaluated electronically.

Access trip computer vehicle data by pressing the **BC** button on the Infotainment system or the left adjuster wheel * on the steering wheel.

Some information appears in the display in an abbreviated form.

Once an audio function has been selected, the subsequent rows of the trip computer function are displayed.

The functions are displayed in the following order:

- Instantaneous consumption
- Average consumption
- Effective consumption
- Average speed
- Distance
- Range
- Stop watch

Instantaneous consumption



Display changes depending on speed:

Display in gal/h	below 8 mph (13 km/h),
Display in mpg	above 8 mph (13 km/h).

Average consumption

Display of average consumption. The measurement can be reset at any time and restarted, see "Reset".

Effective consumption

Display of fuel used. The measurement can be reset at any time and restarted, see "Reset".

Average speed

Display of average speed. The measurement can be reset at any time and restarted, see "Reset".

Stoppages in the journey with the ignition off are not included in the calculations.

Distance

Display of miles / kilometres travelled. The measurement can be reset at any time and restarted, see "Reset".

Range

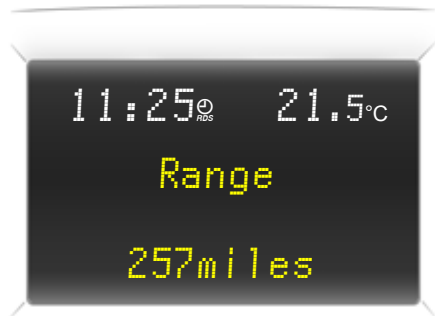

17337 T

Range is calculated from current fuel tank content and instantaneous consumption. The display shows average values.

After refuelling, the vehicle updates the range automatically after a brief delay.

If the fuel in the tank will allow less than 30 miles (50 km) of travel, the message "Range" appears in the display.

If the fuel in the tank will allow less than 20 miles (30 km) of travel, the message "Refuel!" * appears in the display.

Acknowledge the menu item as described on page 95.

Reset: Reset trip computer information

The following trip computer information can be reset (reset and restart measurements or calculations):

- Average consumption,
- Effective consumption,
- Average speed,
- Distance travelled.

Select the desired trip computer information.

Reset by pressing the left adjuster wheel * on the steering wheel or the OK button on the Infotainment system.

Stop watch



17337 T

Select function, operate with the arrow buttons:

Left arrow button

Select menu item Start, start/stop with OK button

Right arrow button

Select menu item Reset, reset with OK button

Operating using the left adjuster wheel * on the steering wheel:

Press

Start/stop.

Interruption of power supply

If the power supply has been interrupted or if the battery voltage has dropped too low, the values stored in the trip computer will be lost.

Graphical Information Display * or colour Information Display * Selecting functions



The functions and settings of some equipment * can be accessed via the Graphical Information Display or the Colour Information Display.

These functions are selected or executed in the menus on the display using the arrow buttons * on the Infotainment system, the multi-function knob * on the Infotainment system or the left adjuster wheel * on the steering wheel.

If check control warning messages * are displayed, the display is locked for other displays. Confirm warning message. If there is more than one warning message, confirm them one after the other.

Selection using four-way buttons

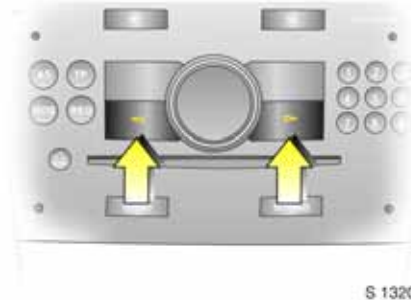

Select menu items via menus and using the buttons on the Infotainment system.

OK button

Select highlighted point, confirm command.

To exit a menu, press the right or left arrow button to execute **Return** or **Main**.

To select using the multi-function knob



Turn

Highlighting menu options or commands, selection of function areas,

Press

Select highlight, confirm commands.

To exit a menu, turn the multi-function knob left or right to **Return** or **Main** and select.

Selection using the left adjuster wheel * on the steering wheel:



Turn up
previous menu item,

Turn down
next menu item,

Press
select highlight, confirm commands.

Function areas



For each functional area there is a main page (Main), which is selected at the top edge of the display (not with the Infotainment system CD 30 without the hands-free mobile phone system):

- Audio,
- Navigation *
- Telephone *
- Trip computer *.

For Audio, Navigation * and Telephone * functions – see Infotainment system instructions.

System settings

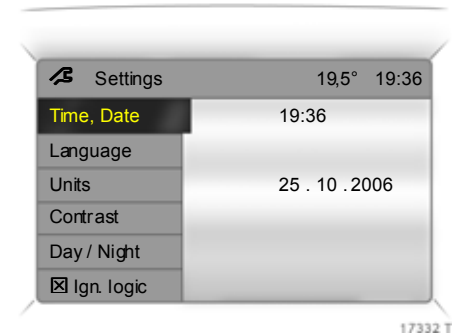

The settings are accessed via the **Settings** menu.

Press the **Main** button * (not found on all Infotainment systems) on the Infotainment system (call up main display).

Press the **Settings** button on the Infotainment system. For Infotainment system CD 30, no menu may be selected.

The **Settings** menu is displayed.

Setting date and time *

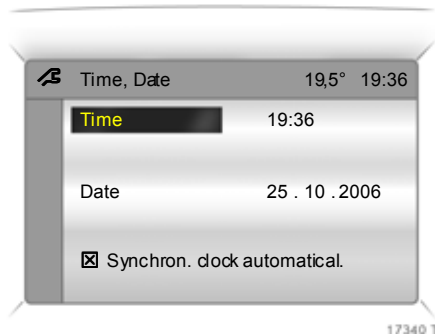

Select menu item **Time, Date**, from the **Settings** menu.

The menu for **Time, Date** is displayed.

Select the menu items required:

Make the desired setting.

Correcting time *

In systems with GPS receiver¹⁾, date and time are set automatically upon receipt of a GPS satellite signal. If the displayed time does not match local time, it can be corrected manually or automatically by receiving an RDS time signal²⁾ *.

Some RDS transmitters do not send correct time signals. If the incorrect time is displayed often, deactivate automatic time synchronisation * and set the time manually.

- 1) **GPS** = **G**lobal **P**ositioning **S**ystem, Satellite system for global positioning.
 2) **RDS** = **R**adio **D**ata **S**ystem.

To correct time with the help of RDS, select menu item **Synchron. clock automatical.** from the **Time, Date** menu.

The box in front of **Synchron. clock automatical.** will be ticked; see Fig. 17340 T.

Language selection

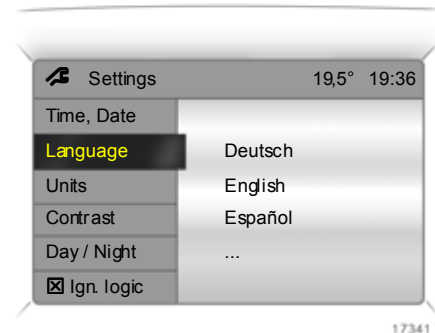

You can select the display language for some functions.

Select menu item **Language** from the **Settings** menu.

The available languages are displayed.

Select the desired language.

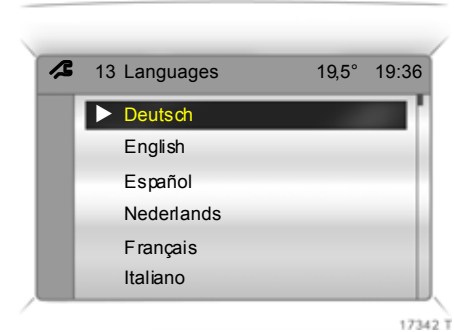

Selections are indicated by a ► in front of the menu item.

In systems with voice output *, when the language setting of the display is changed the system will ask whether the announcement language should also be changed – see Infotainment system instructions.

Setting units of measure

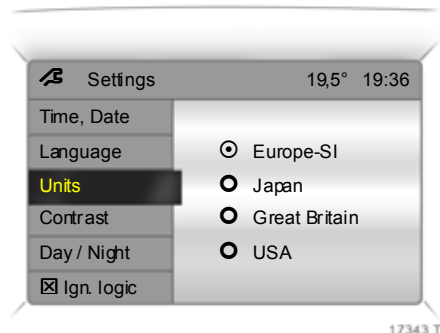

You can select which units of measure are to be used.

Select menu item **Units** from the **Settings** menu.

The available units are displayed.

Select the desired unit.

Selections are indicated by a ● in front of the menu item.

Adjusting contrast * (Graphical Information Display)

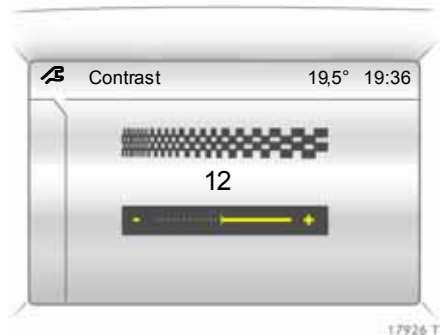

Select menu item **Contrast** from the **Settings** menu.

The menu for **Contrast** is displayed.

Confirm the required setting.

Setting display mode *

The display can be adjusted to suit the light conditions, black or coloured text on a light background or white or coloured text on a dark background.

Select menu item **Day / Night** from the **Settings** menu.

The options are displayed.

Automatic: adapted based on vehicle lighting.

Always day design: black or coloured text on light background.

Always night design: white or coloured text on dark background.

Selections are indicated by a ● in front of the menu item.

Ignition logic *

See Infotainment system instructions.

Graphical Information Display * or Colour Information Display *, trip computer *

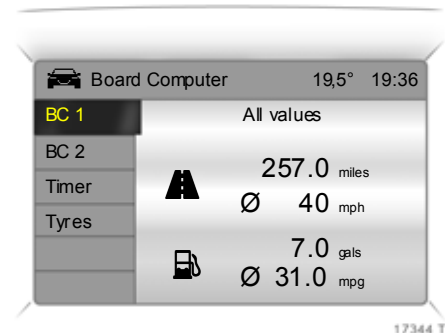

The trip computers provide information on driving data, which is continuously recorded and evaluated electronically.

The main trip computer page provides information on range, instantaneous consumption and average consumption *.

To display other trip computer data, press the **BC** button on the Infotainment system *, select the trip computer menu front the display or press the left a djuster wheel * on the steering wheel.

Range



17329 T

Range is calculated from current fuel tank content and instantaneous consumption. The display shows average values.

After refuelling, the vehicle updates the range automatically after a brief delay.



17345 T

If the fuel in the tank will allow less than 30 miles (50 km) of travel, the message "Range" appears in the display.

If the fuel in the tank will allow less than 20 miles (30 km) of travel, the message "Please refuel!" * appears in the display.

Acknowledge the menu item as described on page 95.

Instantaneous consumption

Display changes depending on speed:

- Display in gal/h below 8 mph (13 km/h),
- Display in mpg above 8 mph (13 km/h).

Distance

Display of miles / kilometres travelled. The measurement can be reset at any time and restarted, see "Reset".

Average speed

Calculation of average speed. The measurement can be reset at any time and restarted, see "Reset".

Stoppages in the journey with the ignition off are not included in the calculations.

Effective consumption

Display of fuel used. The measurement can be reset at any time and restarted, see "Reset".

Average consumption

Calculation of average consumption. The measurement can be reset at any time and restarted, see "Reset".

Reset: Reset trip computer information

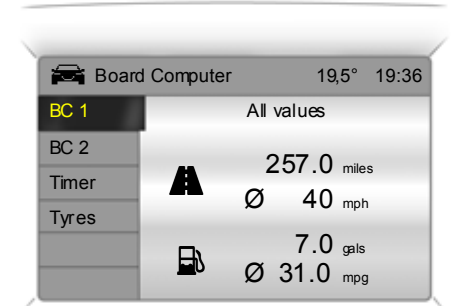

17344 T

The following trip computer information can be reset (restart measurements):

- Distance
- Average speed
- Effective consumption
- Average consumption

Select **BC 1** or **BC 2** from the trip computer menu.

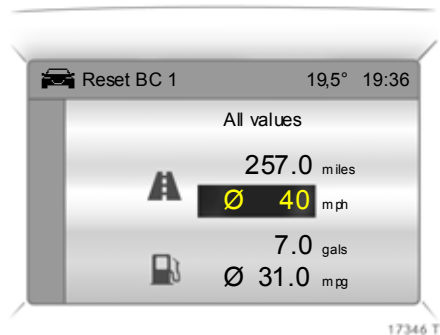

The information of the two trip computers can be reset separately, making it possible to evaluate data from different time periods.

Select the desired trip computer information.

The value for the selected function will be reset and recalculated.

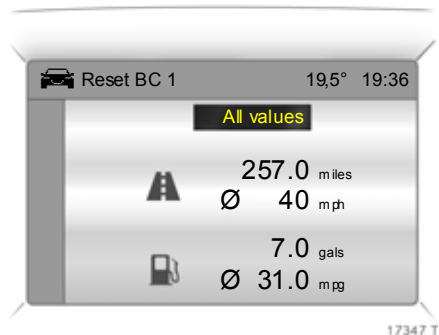

To reset all information of a trip computer, select menu item **All values**.

After resetting, "-" is displayed with the trip computer information selected. The recalculated values are displayed after a short time.

Interruption of power supply

If the power supply has been interrupted or if the battery voltage has dropped too low, the values stored in the trip computer will be lost.

Stop watch

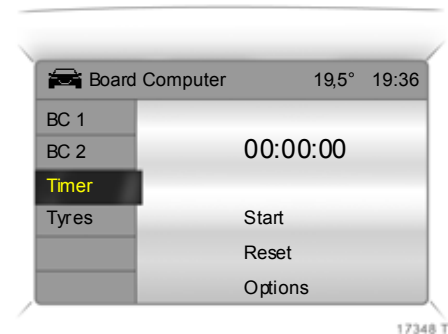

Select menu item **Timer** from the **Board Computer** menu.

The **Timer** menu is displayed.

To start, select menu item **Start**.

To reset, select menu item **Reset**.

The relevant stop watch display can be selected in menu **Options** ✱.

Driving Time excl. Stops

The time the vehicle is in motion is recorded. Stationary time is not included.

Driving Time incl. Stops

The time the vehicle is in motion is recorded. The time the vehicle is stationary with the key in the starter switch is included.

Travel Time

Measurement of the time from manual activation via **Start** to manual deactivation via **Reset**.

Display of current tyre pressure *

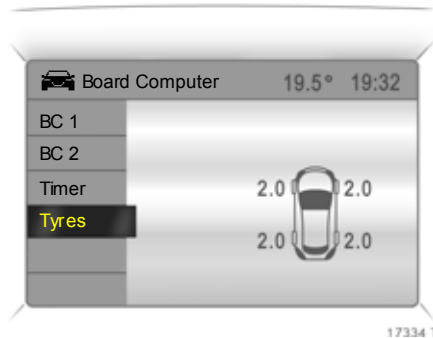

Select menu item **Tyres** from the **Board Computer** menu.

The current pressure of each tyre is displayed.

Further information – see page 155.

Check control *

Check control monitors some fluid levels, the tyre pressure *, battery of the remote control, the Vauxhall alarm system *, the brake light switch and important exterior lights, including cable and fuses. In trailer mode, the trailer lighting is also monitored.

Warning messages appear on the display. If there are several warning messages, they are displayed one after the other.

Some of the warning messages appear on the display in an abbreviated form.

Examples of warning messages for the Graphical Information Display * and Colour Information Display * are shown. On the Board Information Display, messages appear in an abbreviated form.

Acknowledge warning messages as

described on pages 91, 95.

Unacknowledged warning messages can be re-displayed later.

Warning messages:

Remote Control Battery check

Battery voltage of remote control or electronic key of Open&Start system * too low – see pages 33,36.

Brakelight switch check

Fault. Brake light not coming on under braking. Have the cause of the fault rectified immediately by a workshop.

Safeguard check

Fault. System fault in Vauxhall alarm system. Have the cause of the fault rectified immediately by a workshop.

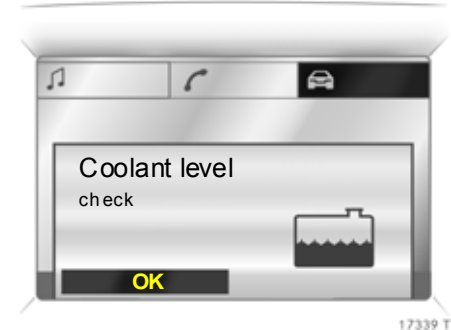

If there is a fault in the vehicle lighting, the respective location of the fault is displayed as text, e.g.:

Brakelight check right

In vehicles with Tyre Pressure Monitoring System *, if tyre pressure is too low, the display indicates which tyre to check, e.g.:

Tyre pressure check rear right (value in bar)

Check tyre pressure at next opportunity using suitable gauge. Tyre Pressure Monitoring System * – see page 155. Checking tyre pressure – see pages 160, 220.

In vehicles with Tyre Pressure Monitoring System ✱, if there is major loss of pressure in a tyre, the display indicates the tyre at fault, e.g.:

Attention!
Rear left tyre pressure loss (value in bar)

Stop immediately and check tyres and pressures. Tyre Pressure Monitoring System ✱ – see page 155.

Washer Fluid Level check

Fluid level in windscreen wash system too low. Topping up wash fluid – see page 207.

Coolant level check

Fluid level in engine cooling system is low. Check coolant level – see page 204.

Interruption of power supply

Stored warning messages appear on the display one after the other.

Warning buzzers

When starting the engine or whilst driving:

- if the electronic key of the Open&Start system is not present or unrecognised ✱,
- if driver’s seat belt is not fastened ✱,
- if the doors or the tailgate have not been properly closed when starting-off,
- once you have reached a certain speed if the handbrake is applied ✱,
- if a defined maximum speed is exceeded ✱,
- with Easytronic ✱, if the engine is running **A, M** or **R** with footbrake not applied and driver’s door has been opened.

When the vehicle is parked and the driver’s door is opened:

- when the key is in the starter switch,
- with parking lights or dipped beam on,
- with the Open&Start system ✱ and automatic transmission if the selector lever is not in **P**.
- with Easytronic ✱ – if the handbrake is not applied and no gear is engaged when the engine is off.

Windscreen wiper

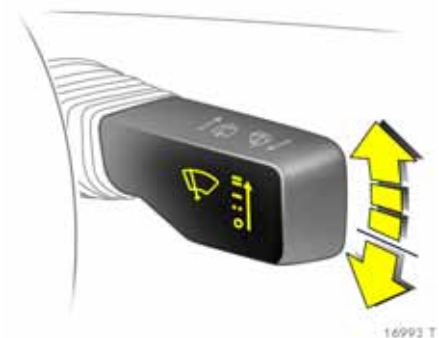

To switch on, press stalk lightly upwards.

- = Off
- = Adjustable timed interval wipe
- = Slow
- == = Fast

Stalk always moves back to starting position. Shift to next higher or lower level: move stalk slightly.

Push stalk past resistance point and hold: the windscreen wiper stages are run through; an acoustic signal sounds at position ○.

Press stalk down from position ○: Single swipe.

Adjustable wiper interval ✱

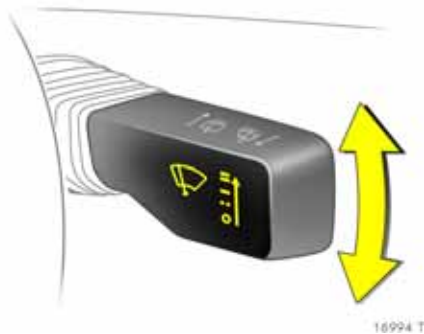

To set the wiper interval to a value between 2 and 15 seconds: Switch on ignition, stalk down from position 0, wait until wiping frequency reaches the desired interval time, stalk to timed interval wipe --.

The interval time selected remains stored until it is next changed or the ignition is turned off.

After turning on the ignition and setting the stalk to --, the interval is set to 6 seconds.

Automatic wiping with rain sensor ✱

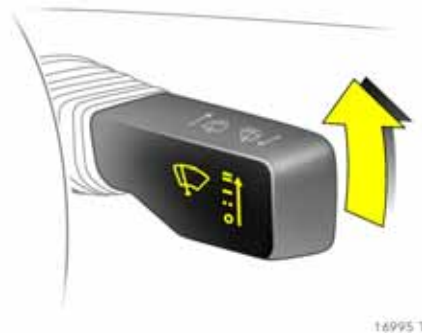

To switch on, press stalk lightly upwards.

-- = Automatic wiping with rain sensor
 O = Off

The rain sensor detects the amount of water on the windscreen and automatically regulates the windscreen wiper.

Keep the rain sensor field clear of dirt by operating the windscreen wash system regularly.

Windscreen wash system and headlight wash system ✱

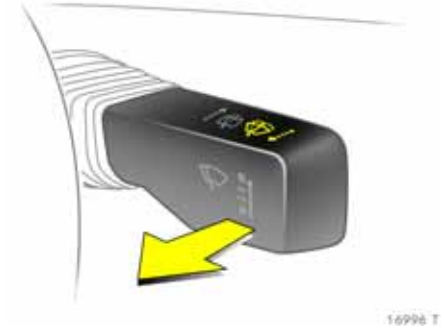

To operate, pull stalk towards steering wheel.

The wiper swipes for a few strokes. At low speeds, there is a single post-wash swipe.

The headlight wash system ✱ can be operated when the lights are on. Wash fluid is sprayed on the headlights once only. Then the headlight wash system cannot be operated for 2 minutes.

On vehicles fitted with rain sensor ✱, keep the sensor area clean.

Rear window wiper and wash system

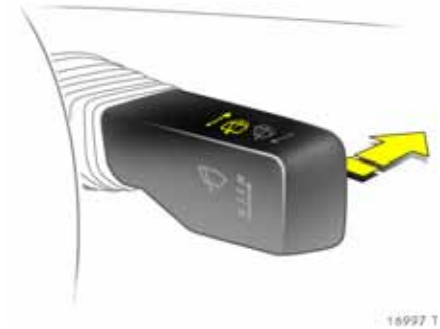

To switch on, press stalk forwards.

The rear window wiper swipes in timed interval mode.

The rear window wiper engages automatically when the windscreen wiper is switched on and reverse gear is engaged.

To switch off, press stalk forwards again.

If the stalk is held forwards, the rear screen wash system switches on for the period of activation.

Lighting

Exterior lights 105
 Main beam, headlight flash 105
 Automatic dipped beam activation * 106
 Turn signals 106
 Front fog lights \mathbb{D} * 106
 Fog tail light \mathbb{Q} 107
 Reversing lights 107
 Hazard warning lights 107
 Headlight range adjustment \mathbb{D} 107
 Adaptive Forward Lighting (AFL) * .. 108
 Door-to-door lighting * 108
 Parking lights * 109
 Instrument illumination
 Information display illumination 109
 Courtesy light 109
 Puddle light * 110
 Battery discharge protection 110
 Light covers 111
 Headlights when driving abroad 111

Exterior lights



Turn light switch:

- O** = Off
- \mathbb{D} = Parking lights
- \mathbb{D} = Dipped beam or main beam

In positions \mathbb{D} and \mathbb{D} , the tail lights and number plate lights are also lit.

Control indicator \mathbb{D} – see page 85.

If the ignition is switched off with the dipped beam or main beam on, the parking lights illuminate.

Versions with daytime running lights *:

Parking lights are on when the ignition is switched on and the light switch is set to **O** or **AUTO**. Dipped beam is on when the engine is running.

The daytime running lights switch off when the ignition is switched off.

Follow the regulations of the country in which you are driving when using daytime running lights and front fog lights *.

Driving in foreign countries – see page 111.

Main beam, headlight flash

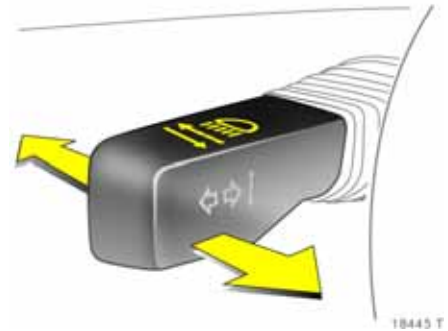

To switch from dipped to main beam, press stalk forwards and hold.

To switch to dipped beam, press stalk forwards again or pull towards steering wheel.

To activate the headlight flash, pull stalk towards steering wheel. The main beam is switched on while activated.

The blue control indicator \mathbb{D} is illuminated when main beam or headlight flash is on.

Automatic dipped beam activation *



17123 T

Light switch to **AUTO**: Dipped beam comes on automatically when the engine is running if outside light conditions warrant such.

The exterior lights switch off when the ignition is switched off.

For reasons of safety, the light switch should always remain in the **AUTO** position.

Turn signals

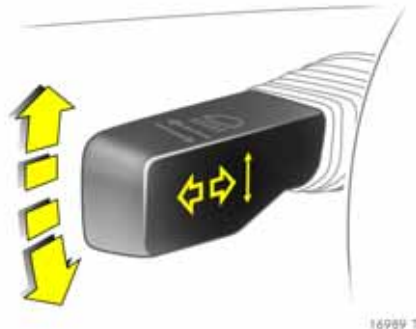

16989 T

To switch on, press stalk up or down.

- Stalk up = Right turn signal light
- Stalk down = Left turn signal light

After operation, the turn signal stalk returns to its starting position.

If the stalk is moved past the resistance point, the turn signal light remains on. When the steering wheel moves back towards the straight-ahead position, the turn signal light is automatically deactivated.

Tap signal: Move stalk to resistance point and release to activate three flashes from the turn signals when changing lanes or the like.

Move the stalk to the resistance point and hold for the turn signals to flash longer.

Switch the turn signal off manually by moving the stalk slightly.

Front fog lights #D*



18492 T

The front fog lights can only be switched on when both the ignition and lights are on.

- On = Press #D, #D illuminates in the instrument cluster
- Off = Press #D again or switch off ignition or light

Fog tail light ☁



18493 T

The fog tail light can only be switched on both the ignition and dipped beam/parking lights are on.

- On = Press ☁, ☁ illuminates in the instrument cluster
- Off = Press ☁ again or switch off ignition or light

The vehicle fog tail light are deactivated when towing.

Reversing lights

Come on when reverse gear is engaged and ignition is switched on.

Hazard warning lights



16991 T

To switch on, press button ▲.

To switch off, press button ▲ again.

To aid location of the pushbutton, the red surface is illuminated with the ignition switched on. When the button is pressed, its control indicator flashes in time with the hazard warning lights.

The hazard warning lights illuminate automatically when the airbag is triggered, and also the central locking unlocks all doors. Switch off hazard warning lights using button ▲.

Headlight range adjustment ↻ Manual headlight range adjustment ✱



17125 T

With dipped beam switched on, push to release knob and adjust headlight range in four steps to suit vehicle load. Turn wheel against resistance and click it to the required position.

Correct adjustment of the headlight range reduces dazzle for other road users.

Automatic level control system ✱ – see page 153.

Vehicles without level control system

- 0 = Front seats occupied
- 1 = All seats occupied
- 2 = All seats occupied and luggage compartment load
- 3 = Driver's seat occupied and luggage compartment load

Vehicles with level control system

- 0 = Front seats occupied
- 1 = All seats occupied
- 1 = All seats occupied and luggage compartment load
- 2 = Driver's seat occupied and luggage compartment load

Automatic headlight range adjustment *

In vehicles with Xenon headlights the headlight range is automatically adjusted depending on the vehicle load.

Adaptive Forward Lighting (AFL) *

AFL improves lighting in curves (curve lighting) on vehicles with Bi-Xenon headlight system.

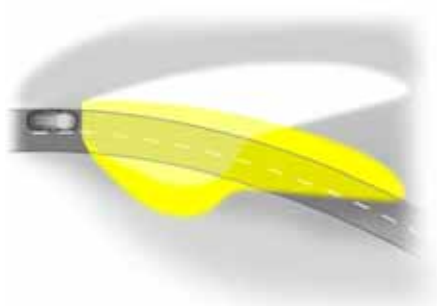

S 14320

Curve lighting

The Xenon light beam pivots based on steering wheel position and speed (from approx. 6 mph (10 km/h)).

The headlights shine at an angle of up to 15° to the right or left of the direction of travel.

Motorway lighting

At higher speeds and continuous straight ahead travel, the dipped beam automatically raises slightly, thereby increasing headlight range.

Control indicator  for Adaptive Forward Lighting



17127 T

Illuminated: Fault in system. The system is not ready for operation.

If the curve lighting swivelling device fails, the relevant dipped beam is switched off. The corresponding fog light is automatically switched on for reasons of safety.

Seek the assistance of a workshop.

If the control indicator  flashes for approx. 4 seconds after the ignition is switched on, the headlights have been set to symmetrical dipped beam; see "Headlights when driving abroad" on page 111.

Door-to-door lighting *



17126 T

Dipped beam and reversing lights * illuminate for around 30 seconds after the driver exits the vehicle and closes his door.

To activate

1. Switch off ignition.
2. Remove ignition key *

3. Open driver's door.
4. Pull turn signal stalk towards steering wheel.
5. Close driver's door.

If the driver's door is not closed the lights go off after two minutes.

The light is immediately switched off when the key is placed in the ignition or the turn signal stalk is moved back to the steering wheel when the driver's door is opened.

Parking lights ✱

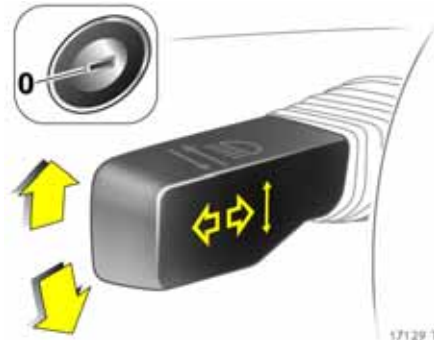

The front parking light and tail light of one side of the vehicle can be activated when parking:

1. Set light switch to **0** or **AUTO ✱**,
2. Ignition off,
3. Move turn signal stalk all the way up (right parking light) or down (left parking light).

An acoustic signal sounds and control indicator  illuminates briefly in the instrument cluster to indicate activation.

To switch it off, switch on the ignition or move the turn signal stalk in the opposite direction.

Instrument illumination Information display illumination



Lights come on when ignition is switched on.

Brightness can be adjusted when the exterior lights are on: Push to release knob  and then turn it clockwise or anticlockwise and hold until the desired brightness is obtained.

Display mode ✱ – see page 98.

Courtesy light

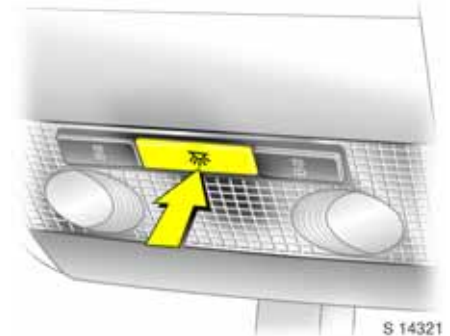



Automatic interior light

Comes on automatically when the vehicle is unlocked with the remote control, when a door is opened or when the key is removed from the starter switch after the ignition is switched off.

Automatically switches off after a delay after closing the doors and immediately when the ignition is switched on or after locking the doors.

Front courtesy light



Manual operation from the inside with closed doors:

- On = Press button 
 Off = Press button  again

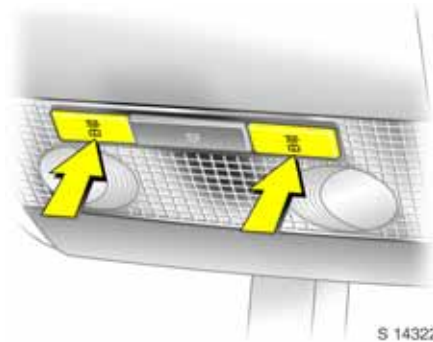
Front reading lights*



Reading lights on left and right individually operable with ignition tuned on:

- On = Press button 
- Off = Press button  again

Courtesy lights and reading lights in the centre and the rear*



Centre switch position: the centre and rear courtesy lights come on together with the front courtesy light.

Rear reading lights on left and right individually operable with ignition switched on:

- On = Switch position I
- Off = Switch position 0

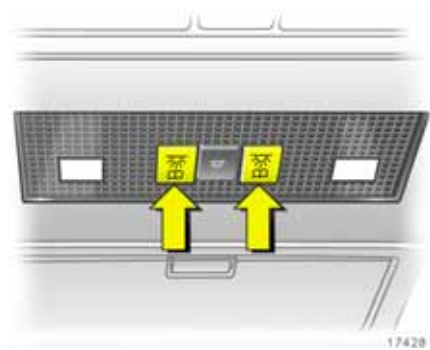

Courtesy lights and reading lights in the centre*



The courtesy lights come on together with the front interior lights.

To deactivate the courtesy lights, press * button .

The rear right and left reading lights can be switched on separately with the ignition switched on:

- On = Press button 
- Off = Press button  again

Entry lighting*

After unlocking the vehicle, the instrument and switch lighting come on for a few seconds.

Door handle lighting*

When the exterior lights are on, the interior front door handles are illuminated.

Illuminated mirrors in the sunvisors*

The lighting switches on when the cover is opened.

Glove compartment lighting

Comes on when lid is open.

Cigarette lighter and ashtray illumination*

Comes on when ignition is switched on.

Luggage compartment lighting

Comes on when the boot lid/tailgate is opened.

Automatically regulated centre console lighting*

Spot light in internal mirror housing.

Daylight-dependent, automatically regulated centre console lighting with ignition switched on.

Puddle light*

After unlocking the vehicle, the number plate lights come on for a few seconds.

Battery discharge protection

To prevent the battery from becoming discharged, the courtesy light, reading lights, luggage compartment lighting and

glove compartment lighting switch off automatically 10 minutes after the ignition is switched off.

Light covers

The inside of the light covers may mist up briefly in poor, wet and cold weather conditions, in heavy rain or after washing. The mist disappears quickly by itself; to help, switch on the lights.

Headlights when driving abroad

The asymmetrical dipped beam extends visibility at the edge of the road at the passenger's side.

This causes glare for oncoming traffic if the vehicle is driven in countries where traffic drives on the opposite side of the road.

Do as follows to prevent glare:

Vehicles with halogen headlight system or Xenon headlight system *

Have the headlights adjusted by a workshop.

Vehicles with Adaptive Forward Lighting * (AFL)

1. Pull and hold stalk for main beam on steering wheel (headlight flash)
2. Switch on ignition.
3. After approx. 3 seconds, an acoustic signal sounds and then AFL control indicator  flashes approx. 4 seconds.

After the switch, AFL control indicator  flashes for 4 seconds each time the ignition is switched on.

To return to asymmetrical dipped beam, pull and hold the main beam stalk again, switch on the ignition and wait for the acoustic signal. AFL control indicator  will then discontinue flashing.

Control indicator  – see page 108.

Infotainment System

Radio reception *..... 112
 Remote control on steering wheel *.. 112
 Twin Audio *..... 112
 AUX input *..... 113
 Mobile telephones and
 radio equipment *..... 113
 Infotainment system *..... 113

Radio reception *

Vehicle radio reception differs from domestic radio reception:

As the vehicle antenna is relatively near the ground, the broadcasting companies cannot guarantee the same quality of reception as obtained with a domestic radio using an overhead antenna.

- Changes in distance from the transmitter,
 - multi-path reception due to reflection and
 - shadowing
- may cause static, noise, distortion or loss of reception altogether.

Remote control on steering wheel *

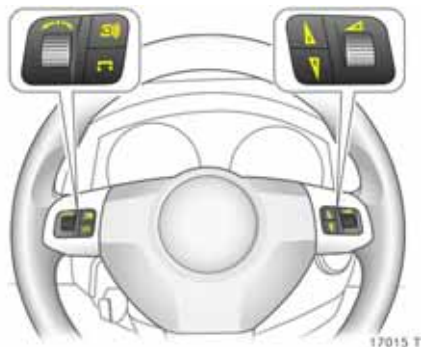

The functions of the Infotainment system * and the information display can be operated on the steering wheel.

Further information – see page 96 and the relevant operating instructions.

Twin Audio *

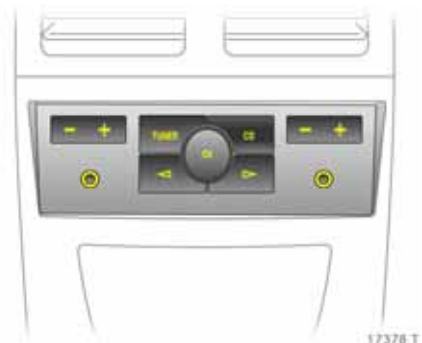

Twin Audio provides rear seat occupants with the opportunity to listen to a different audio source than the one selected by the driver on the Infotainment system.

Only an audio source that is not currently active on the radio system can be controlled using Twin Audio.

Two headphone connections are available, with separate volume controls.

Further information is available in the Infotainment system operating instructions.

AUX input ❄

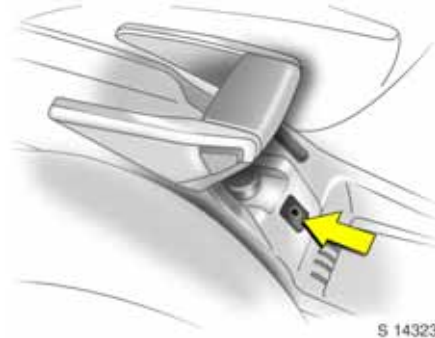

The AUX input is located in the centre console, in front of the handbrake.

An external audio source, such as a portable CD player, can be connected via the AUX input.

Always keep the AUX input clean and dry.

Further information is available in the Infotainment system operating instructions.

Mobile telephones and radio equipment ❄

The Vauxhall installation instructions and the operating guidelines provided by the telephone manufacturer must be observed when fitting and operating a mobile telephone. Failure to do so could invalidate the vehicle's operating permit (EU Directive 95/54/EG).

Recommended prerequisites for fault-free operation:

- Professionally installed exterior antenna to obtain the maximum range possible,
- Maximum transmission power 10 Watt,
- Installation of the telephone in a suitable spot (see information on page 75).

Obtain advice on predetermined installation locations for the external antenna and equipment holder and ways of using devices with transmission power of more than 10 Watts. We recommend that you consult your Vauxhall Authorised Repairer, who will have brackets and various installation kits available as accessories and will install them in accordance with regulations.

Operation of a hands-free attachment with no outside antenna using the mobile telephone standards GSM 900/1800/1900 and UMTS may take place only if the maximum transmission power of the mobile telephone does not exceed 2 W in the case of GSM 900 and otherwise 1 W. The operating instructions of the manufacturer of the telephone and hands-free attachment must be noted in all cases.

For reasons of safety, we recommend that you do not use the phone whilst driving. Even use of a hands-free set can be a distraction whilst driving. Be sure to observe any country-specific regulations.

Warning

Mobile telephones and radio equipment may lead to malfunctions in the vehicle electronics when operated inside the vehicle with no exterior aerial, unless the current regulations are observed.

Operate radio equipment and mobile telephones which fail to meet current mobile telephone standards only using an antenna located outside of the vehicle.

Infotainment system ❄

The Infotainment system is operated as described in the operating instructions.

Climate Control

Heating and ventilation system, air conditioning system *	114
Automatic air conditioning system *	114
Electronic Climate Control (ECC) *	115
Air vents	115
Heated rear window, heated exterior mirrors *	116
Heated front seats *	116
Cooled glove compartment *	117
Heating and ventilation system	117
Air conditioning system *	119
Automatic air conditioning system *	121
Electronic Climate Control (ECC) *	125
Air intake	130
Pollen filter	130
Note	130
Maintenance	130

Heating and ventilation system, air conditioning system *



Ventilation, heating and cooling * are combined into one unit that is designed to provide comfort regardless of the season, weather or outside temperature.

When cooling * is activated, the air is cooled and dried.

The heating unit heats the air as required in all operating modes depending on the position of the temperature rotary knob. The air supply can be adjusted to suit requirements by means of the fan.



Buttons for cooling * and the air recirculation system are only present in the version with air conditioning system *.

Air conditioning system * – see page 119.

Automatic air conditioning system *



Provides a comfortable climate in the interior of the vehicle in any weather conditions, at any outside temperature and at any time of year.

The temperature and the quantity of inflowing air are controlled automatically by preselecting an interior temperature using the temperature regulator. A consistent, pleasant climate is therefore automatically created inside the vehicle, depending on the external climatic conditions.

Automatic air conditioning system – see page 121.

Electronic Climate Control (ECC) *



Provides maximum comfort inside the vehicle, irrespective of the external conditions.



In order to ensure that a consistent and pleasant climate is provided in the vehicle, the temperature of the inflowing air, the quantity of air and the air distribution are automatically adapted to the external climatic conditions and the specified interior temperature.

The settings are shown on the information display.

Electronic automatic air conditioning system – see page 125.

Air vents

Pleasant ventilation in the interior is controlled by the position of the temperature rotary knob.

To increase the air supply, turn the fan to a higher level and set the air distribution rotary knob to  or .

Centre air vents in the instrument panel



Open air vent: rotate horizontal adjuster wheel to I.

Direct the flow of air by tilting and swivelling the slats.

To close the air vent, rotate adjuster wheel to 0.

Top and centre air vents in the instrument panel



Open air vent and adjust direction of airflow: align slats.

To close the slats, direct air vents downwards.

Comfort recommendation: directing the flow of air with the slats in an upright position provides optimum ventilation for the occupants in the second and third rows of seats and also efficiently distributes the heated or cooled air throughout the interior of the vehicle.

Side air vents in the instrument panel and rear air vents in the console between the front seats

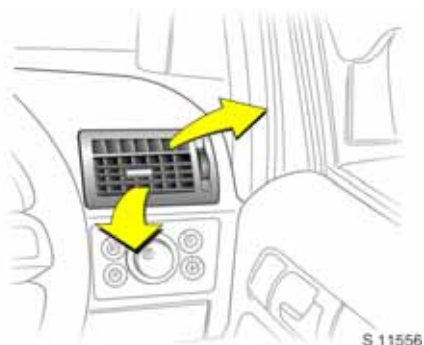

Open air vent: rotate vertical adjuster wheel to **1**.

Direct the flow of air by tilting and swivelling the slats.

To close the air vent, rotate adjuster wheel to **0**.

Additional air vents

Located below the windscreen and door windows and in the footwell.

Heated rear window, heated exterior mirrors ✱



With the ignition on, the rear screen and exterior mirror heating is switched on by pressing button .

LED  illuminates: rear screen and exterior mirror heating.

LED  does not illuminate: rear screen and exterior mirror heating is switched off.

Heating works with the engine running and is switched off automatically after around 15 minutes.

Depending on the engine, the heated rear window comes on automatically when the diesel particle filter is being cleaned ✱.

Heated front seats ✱



Operation with ignition switched on:

Press button  one or more times to set the desired heat output. The control indicator in the button indicates which of the three heating levels is active.

We do not recommend prolonged use of the highest level for people with sensitive skin.

Deactivation: Press button  repeatedly until the control indicator goes out.

Seat heating is operational when the engine is running.

Cooled glove compartment ✱



Cooled air is fed into the glove compartment through a nozzle.

If glove compartment cooling is not required, move slider to the front.

Heating and ventilation system Air distribution

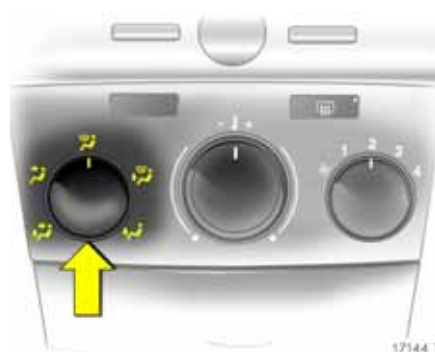

Set using left-hand rotary knob

- 🚗 for head area via adjustable air vents, for footwell
- 🚗 for head area via adjustable air vents
- 🚗 for windscreen and front door windows
- 🚗 for windscreen, front door windows, footwell
- 🚗 for footwell

Intermediate settings are possible.

Open the air vents when the rotary knob is set to 🚗 or 🚗.

Temperature



Set using centre rotary knob

- Red area = warm
- Blue area = cold

Airflow



Set using right-hand rotary knob

Four fan speeds:

- ❖ Off
- 4 Maximum rate of airflow

The rate of airflow is determined by the fan. The fan should therefore also be switched on during a journey.

Ventilation



- For maximum ventilation in the head area: move air distribution rotary knob to 2, open all air vents, move slats of top and centre air vents to an upright position – see page 115,
- Set the temperature to the desired setting,
- Switch on fan, adjust fan according to requirements,
- For ventilation to footwell: set air distribution rotary knob to 3,
- For simultaneous ventilation to the head area and the footwell: set air distribution rotary knob to 4.

Heating

The amount of heat is dependent on the coolant temperature and is thus not fully attained until the engine is warm.

For rapid warming of the passenger compartment:

- Set air distribution rotary knob to the desired position, preferably position 4 – see page 117,
- Turn the temperature rotary knob clockwise as far as it will go,
- Switch on fan stage 3,
- Open all air vents.

Vehicles with Quickheat ❖:

Depending on external temperature and engine temperature, the passenger compartment is heated more quickly with electric auxiliary heating.

The electrical auxiliary heating switches on automatically.

The comfort and general well-being of the vehicle occupants are to a large extent dependent on a suitable ventilation and heating setting.

To achieve a stratification of temperature with the pleasant effect of "cool head and warm feet", turn the rotary knob for air distribution to 3 or 4, set temperature rotary knob to any position (in the mid-range with stratification of temperature).

Heating the footwell



- Set air distribution rotary knob to ,
- Temperature rotary knob in right zone,
- Switch on fan.



Demisting and defrosting the windows

Warning

Failure to follow the instructions can lead to window fogging or icing and therefore accidents due to lack of visibility.



Window fogging or icing, e.g. in damp weather, because of wet clothing or due to low outside temperatures.

- Move air distribution rotary knob to .
- Turn the temperature rotary knob clockwise as far as it will go (warm).
- Set fan to 3 or 4.
- Switch on heated rear window .
- Open side air vents as required and direct them towards door windows.

- For simultaneous warming of the footwell, set air distribution rotary knob to .

Air conditioning system *

As well as the effect of the heating and cooling system, the air conditioning system also cools and dries the inflowing air.



If no cooling or drying is required, switch the cooling system off to save fuel.

At low outside temperatures the cooling unit switches off automatically.

Cooling





Operate only with the engine running and the fan on:

- On = Press 
 Off = Press  again

Control indicator in button.

Air recirculation system 

The air recirculation button  is used to set the ventilation system to air recirculation mode (control indicator illuminates in button).

If fumes or unpleasant odours penetrate from outside: temporarily switch on air recirculation system .





To increase the cooling power at high outside temperatures, temporarily switch on the air recirculation system.

The air recirculation system minimises the entry of outside air. The humidity increases, and the windows can mist up. The quality of the passenger compartment air deteriorates which may cause the vehicle occupants to feel drowsy.

Air distribution to : the air recirculation system is automatically switched off to speed up window demisting and avoid fogging.

Convenience settings





- Set cooling  as desired.
- Air circulation system  off.
- Set air distribution rotary knob to  or .
- Set temperature rotary knob to desired position.
- Switch on fan at desired speed.
- Open or align air vents as required.

Temperature rotary knob in centre of adjustment range: warmer air will flow into the footwell and cooler air into the upper zone, with warmer air coming from the side air vents and cooler air from the centre air vents.

Maximum cooling



Briefly open the window so that warm air can dissipate quickly.

- Cooling  on.
- Air circulation system  on.
- Set air distribution rotary knob to .
- Turn the temperature rotary knob anticlockwise as far as it will go (cold).
- Set fan to 4.
- Open all air vents.



Demisting and defrosting the windows

Warning

Failure to follow the instructions can lead to window fogging or icing and therefore accidents due to lack of visibility.



Window fogging or icing, e.g. in damp weather, because of wet clothing or due to low outside temperatures.

- Cooling  on, the air conditioning compressor automatically switches off in low outdoor temperatures (ice formation),
- Move air distribution rotary knob to .
- Turn the temperature rotary knob clockwise.
- Set fan to 4.

- Open side air vents as required and direct them towards door windows.
- Switch on heated rear window .
- Open side air vents as required and direct them towards door windows.

Automatic air conditioning system *

It provides consistent comfort in the interior of the vehicle in any weather conditions, at any outside temperature and at any time of year.

In order to ensure that the climate in the vehicle is consistent and pleasant, the temperature of the inflowing air and the quantity of air are automatically adapted to the external climatic conditions.

Temperature changes due to external influences, such as direct sunlight, are automatically compensated.

Automatic mode



Basic setting for maximum comfort:

- Turn fan rotary knob to **A**,
- Adjust air distribution rotary knob in accordance with requirements, see next column,
- Preset temperature to 22 °C using rotary knob (higher or lower if required),
- Air conditioning compressor activation – see page 123,
- Open all of the air vents in the front (and the rear air vents if required) *.

Switching off the air conditioning compressor can have an adverse effect on comfort and safety – see page 123.

Air distribution



Set using left-hand rotary knob

- for head area via adjustable air vents, for footwell
- for head area via adjustable air vents
- for windscreen and front door windows
- for windscreen, front door windows, footwell
- for footwell

Intermediate settings are possible.

Open the air vents when the rotary knob is set to or .

Temperature preselection



Set using centre rotary knob

Move rotary knob to a value of between 17 °C and 27 °C. Intermediate settings are possible.

The preselected temperature is kept constant.

For reasons of comfort, temperature can only be changed in small increments.

No temperature control takes place at a setting of less than 17 °C (left-most position) or more than 27 °C (right-most position), but the air conditioning system operates at maximum cooling or heating power.

Airflow



Set using right-hand rotary knob

- 1 - 4** Manual setting of the fan speed, intermediate settings are possible.
- A** Automatic control of fan speed
- Fan off

The fan speed determines the airflow that is needed to maintain the preselected temperature.



Select automatic mode for maximum comfort.

The air conditioning compressor is switched off when the fan is switched off.

Air conditioning compressor (cooling) switching on and off



Operate only with the engine running and the fan on:

On = Press 
 Off = Press  again

Control indicator in button.

When cooling (AC compressor) is active, air is cooled and dehumidified. If cooling or dehumidification is not desired, switch off cooling in order to save fuel.

At low outside temperatures the cooling unit switches off automatically.

Manual air recirculation mode



The air recirculation system prevents the entry of outside air and the air in the passenger compartment is circulated.



Press button , control indicator in button.

The exchange of fresh air is reduced in air recirculation mode. The quality of the passenger compartment air deteriorates which may cause the vehicle occupants to feel drowsy. In operation without cooling the air humidity increases, so the windows may mist up. Consequently, manual air recirculation should only be run for short periods of time.

To deactivate manual air recirculation: Press button  again. The control indicator in the button will go out.

Ventilation



- For maximum ventilation in head area: set air distribution rotary knob to  and open all air vents.
- For ventilation to footwell: set air distribution rotary knob to .
- For simultaneous ventilation to the head area and the footwell: set air distribution rotary knob to .
- Select required temperature.
- Move fan rotary knob to **A**, fan can also be set manually if required: move rotary knob to position **1 - 4**, intermediate settings are also possible.

Heating

The amount of heat is dependent on the coolant temperature and is thus not fully attained until the engine is warm.

For rapid warming of the passenger compartment:

- Set the air distribution rotary knob to the desired position – see page 117.
- Set centre rotary knob to required temperature, recommended value approx. 22 °C.
- Set fan to **A**, fan can also be set manually if required: move rotary knob to position **1 - 4**, intermediate settings are also possible.

Vehicles with Quickheat *:

Depending on external temperature and engine temperature, the passenger compartment is heated more quickly with electric auxiliary heating.

The electrical auxiliary heating switches on automatically.

The comfort and general well-being of the vehicle occupants are to a large extent dependent on a suitable ventilation and heating setting.

To achieve a stratification of temperature with the pleasant effect of "cool head and warm feet" effect, move air distribution rotary knob to **3** or **4**, set temperature rotary knob to approx. 22 °C and open centre air vents.

Maximum cooling for extremely warm interior



Briefly open the window so that warm air can dissipate quickly.

- Cooling on,
- Set air distribution rotary knob to **2**,
- Move temperature rotary knob to required temperature value,
- Move fan rotary knob to **A**,
- Open all air vents.

At settings below 17 °C (rotary knob all the way to the left), the system continually runs with maximum cooling. When the air conditioning compressor is running, the system is automatically set to air recirculation.

Demisting and defrosting windows

Warning

Failure to follow the instructions can lead to window fogging or icing and therefore accidents due to lack of visibility.



Window fogging or icing, e.g. in damp weather, because of wet clothing or due to low outside temperatures.

- Cooling on,
- Press button : in position **A**, fan automatically switches to maximum speed, the air distribution is directed at the windscreen,
- Set temperature to maximum heating power, i.e. turn central rotary knob clockwise as far as possible (28 °C),
- Switch on heated rear window .

Cooling operation (air conditioning compressor) is not possible at low outside temperatures.

To switch off, press button  again, and the automatic air conditioning system operates at the previously selected setting.

Electronic Climate Control (ECC) *

It provides maximum comfort in the interior of the vehicle in any weather conditions, at any outside temperature and at any time of year.

To ensure a constant and comfortable climate in the vehicle, the temperature of the inflowing air, the airflow rate and the air distribution are changed automatically according to climatic conditions outside the vehicle.

The Electronic Climate Control (ECC) automatically cools to the specified value with the maximum cooling power.

Temperature changes due to external influences, such as direct sunlight, are automatically compensated.

Data is shown on the information display. Setting modifications are briefly shown in the information display, superimposed over the currently displayed menu.

The display can vary according to the type of presentation – see page 89.



The settings in the Electronic Climate Control are stored in the vehicle key when the vehicle is locked, see "Store personal settings in vehicle key" – see page 31.

With various remote controls, stored settings are automatically retrieved by using the relevant remote control.

Manual settings, e.g. operating without cooling, and air distribution can be selected using the menu – see page 126.

When the cooling unit (air conditioning compressor) is on, the air is cooled and dehumidified.

The pollen filter removes dust, soot, pollen and spores from the inflowing outside air.



The automatic air recirculation system has an air quality sensor * to detect harmful gases in the outside air, in which case it will switch automatically to air recirculation.

When set to automatic mode, the Electronic Climate Control provides the optimum settings for practically all conditions. If so desired, the Electronic Climate Control can be manually adjusted.

The Electronic Climate Control is only fully operational when the engine is running.

At low outside temperatures the cooling unit (cooling compressor) switches off automatically.

Automatic mode



Basic setting for maximum comfort:

- Press **AUTO** button,
- Open all air vents,
- Air conditioning compressor activation – see page 127,
- Set preselected temperature to 22 °C using left-hand rotary knob.

The temperature can be set higher or lower as desired.

Switching off the AC compressor (**Eco** appears in display) can reduce comfort and affect safety – see page 127.

All air vents are actuated automatically in automatic mode. The air vents should therefore always be open – see page 115.

Automatic air recirculation mode*

The ventilation system is set to air recirculation mode and interior air is recirculated.

The automatic air recirculation system has an air quality sensor to detect harmful gases in the outside air, in which case it will switch automatically to air recirculation.

If outside temperatures are low and cooling (air conditioning compressor) is switched off, automatic air recirculation is only available in a limited capacity so as to prevent the windows from misting. Activate air recirculation manually if so desired.

Switching automatic air recirculation on or off – see page 129.

Manual air recirculation mode – see page 129.

Temperature preselection

The left-hand rotary knob can be used to set temperatures between 16 °C and 28 °C.

For reasons of comfort, temperature can only be changed in small increments.

Vehicles with Quickheat*:

Depending on external temperature and engine temperature, the passenger compartment is heated more quickly with electric auxiliary heating.

The electrical auxiliary heating switches on automatically.

If a temperature below 16 °C is set, **Lo** appears in the display: the Electronic Climate Control runs constantly at maximum cooling power. The temperature is not regulated.

If a temperature above 28 °C is set, **Hi** appears in the display: the Electronic Climate Control runs constantly at maximum heating power. The temperature is not regulated.

Manual settings

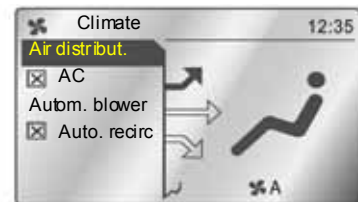

Under certain circumstances (e.g. icy or misted windows), the functions of the Electronic Climate Control can be adjusted manually.

Electronic Climate Control settings can be changed via the centre knob, the buttons and the menu shown on the display.

Press the centre knob to call up the menu. The menu for manual Electronic Climate Control settings appears in the display.

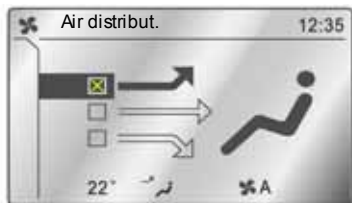

17162 T

Individual menu items are highlighted by turning the centre knob and selected by pressing it. Selecting certain menus by pressing the knob will open a submenu ✨.

To exit a menu, turn the centre knob left or right to **Return** or **Main** and select.

Demisting and defrosting the windows

⚠ Warning

Failure to follow the instructions can lead to window fogging or icing and therefore accidents due to lack of visibility.



18496 T

Window fogging or icing, e.g. in damp weather, because of wet clothing or due to low outside temperatures.

Press button. appears in display: Control indicator in button illuminates.

The temperature and the air distribution are adjusted automatically, the fan runs at a faster speed and the windows are rapidly cleared of ice and moisture.

The airflow can be increased or decreased by turning the right-hand knob.

To return to automatic mode: press button or **AUTO**.

Heated rear window – see page 116.

Switch air conditioning compressor on and off

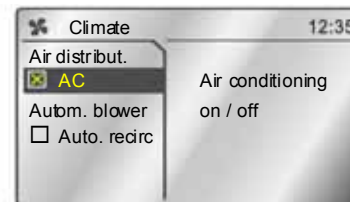

17164 T

If no cooling or dehumidification is required, switch the air conditioning compressor off (maximum energy savings): Highlight menu item **AC** from the manual settings menu and select by pressing the knob. **Eco** appears on the display.

Inflowing air is neither cooled nor dehumidified. This restricts the level of comfort provided by the Electronic Climate Control. This may cause the windows to mist up, for example.

To activate cooling: Select menu item **AC** from the manual settings menu and press to activate cooling.

Air distribution



Press the centre knob. The possible air distribution settings appear one after another in the display.

Air distribution can also be set in the Air distribut. menu:

- Top Air distribution to windscreen and front door windows.
- Centre Air distribution to vehicle occupants via controllable front air vents.
- Bottom Air distribution to footwell.

Return to automatic air distribution:
Deactivate corresponding setting or press **AUTO** button.

Airflow



Turn right-hand knob right or left. The selected fan speed is indicated with a fan icon and the number in the display.

At speed **0** both the fan and cooling (air conditioning compressor) are switched off.

To return to automatic mode: Press **AUTO** button.

Fan control in automatic mode *



Fan regulation in automatic mode can be modified.

Select menu item **Automatic blower** from the manual settings menu and select the desired fan control.

Depending on the setting, the maximum airflow, and thereby the noise level, will increase.

Switching automatic air recirculation * on or off

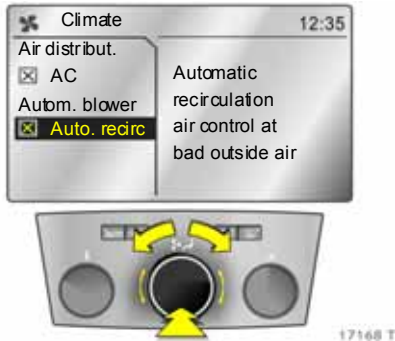

The automatic air recirculation system has an air quality sensor to detect harmful gases in the outside air, in which case it will switch automatically to air recirculation and the interior air is recirculated.

Select menu item **Auto. recirc** from the manual settings menu and switch it on or off by pressing the knob.

Switch to manual air recirculation as necessary.

Manual air recirculation mode



The air recirculation system minimises the entry of outside air and the air in the passenger compartment is recirculated.

Press button , the control indicator in the button will illuminate.

The exchange of fresh air is reduced in air recirculation mode. The quality of the passenger compartment air deteriorates which may cause the vehicle occupants to feel drowsy. In operation without cooling, the air humidity increases, so the windows may mist up. Consequently, manual air recirculation should only be run for short periods of time.

To deactivate manual air recirculation: Press button  again. The control indicator in the button will go out.

Air conditioning with the engine not running



When the vehicle is stopped and the ignition is off, the heat or cooling power still in the system can be used to condition the passenger compartment, for example when stopped at a level crossing.

Press **AUTO** button with the ignition off. **Residual air conditioning on** will appear briefly in the display.

The air conditioning will operate for a limited period of time.

To cancel air conditioning, press the **AUTO** button.

Air intake

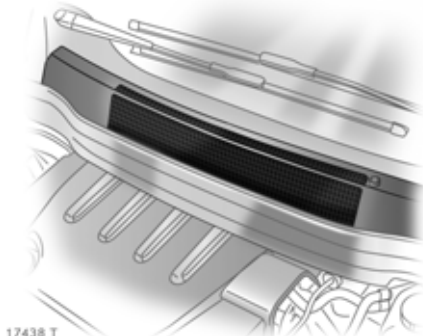

17438 T

The air intakes in front of the windscreen in the engine compartment must be kept clear to allow air intake. Remove any leaves, dirt or snow.

Pollen filter

The pollen filter cleans dust, soot, pollen and spores from the air entering from outside. The active carbon layer ✱ eliminates most odours and harmful ambient gases from the air.

Replace the pollen filter at the intervals given in the Service Booklet.

Note

If the windscreen mists up during damp weather, temporarily set the system as described under "Demisting and defrosting the windows" – see pages 119, 121 and 127.

Cooling ✱ functions most efficiently when the windows are closed. If the passenger compartment has heated up considerably after a long period in direct sunlight, briefly open the windows and sunroof ✱ so that the hot air can escape quickly.

When cooling ✱ (air conditioning compressor) is switched on condensation forms, which is expelled from the underside of the vehicle.

At least one air vent must be open while cooling ✱ (air conditioning compressor) is on in order to prevent the evaporator from icing up due to lack of air movement.

At low outside temperatures the cooling unit switches off automatically.

If you wish the Electronic Climate Control (ECC) ✱ to operate correctly, do not cover the sensor on the instrument panel.

Maintenance

In order to ensure continuously efficient performance, the air conditioning compressor ✱ must be operated for a few minutes once a month, irrespective of the weather and time of year. The Electronic Climate Control (ECC), if present, handles this automatically whilst driving. Air conditioning compressor operation is not possible when outside temperatures are low.

Seek the assistance of a workshop in the event of faults.

Driving and Operation

Easytronic *	131
Automatic transmission *	136
Driving hints	141
Saving fuel, protecting the environment	143
Fuel consumption, fuel, refuelling	144
Catalytic converter, exhaust gases	146
Drive Control Systems	148
Brake system	157
Anti-lock Brake System (ABS)	159
Wheels, tyres	159
Roof racks *	164
Towing equipment *	164
Caravan / trailer towing	167

Easytronic *

The semi-automatic Easytronic manual transmission permits manual (Manual mode) or automatic gearshifting (Automatic mode), both with automatic clutch control.

Warning

Disregard of these instructions may lead to injuries or endanger life.

Transmission display



Shows the mode and current gear.

The display flashes for a few seconds when **A**, **M** or **R** is selected with the engine running and the footbrake not activated.

Starting the engine



18442 T

When starting the engine, depress the footbrake at the same time. The engine may be started only when the footbrake is depressed. In the transmission display, "N" is shown. If the footbrake is not depressed, the control indicator  * comes on in the instrument cluster, and at the same time "N" flashes in the transmission display. The engine cannot be started.

Starting is not possible if all brake lights fail.

There is no need to select neutral before starting the engine. If a gear is engaged, the transmission automatically switches to neutral (N) before the engine starts when the footbrake is operated. This can lead to a slight delay in the starting process.

Easytronic operation via the selector lever

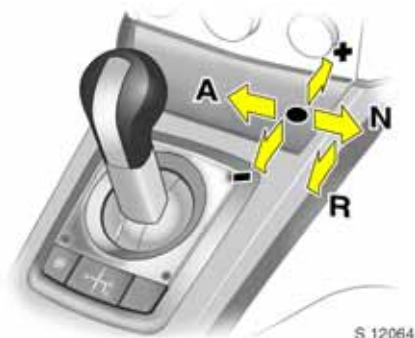

Always move the selector lever in the appropriate direction as far as it will go. Upon release, it automatically returns to the centre position. Pay heed to the gear / mode indicator in the transmission display.

Move selector lever towards N

Neutral

Starting-off



Depress the footbrake, release the handbrake and move the selector lever to **A**, **+** or **-**. Easytronic is in Automatic mode and first gear is engaged (second gear if the Winter programme is active). "A1" appears in the transmission display ("A2" if the Winter programme is active).

The vehicle begins to "creep" when the footbrake is released.

It is also possible to start-off without depressing the footbrake if the accelerator pedal is operated directly after moving the selector lever. If there is no immediate acceleration or the footbrake is not depressed, no gear is engaged and "A" flashes. After a few seconds, the display reverts back to displaying "N". Then repeat the previously described start-off procedure.

In Automatic mode, selection of other gears is automatic irrespective of driving conditions.

Move selector lever towards A

Switch between Automatic and Manual mode.

Manual gearshifting is possible in Manual mode. "M" and the currently engaged gear appear in the display.

If the engine speed is too low the Easytronic will automatically shift to a lower gear even in Manual mode. This prevents the engine from stalling.

Move selector lever towards + or -

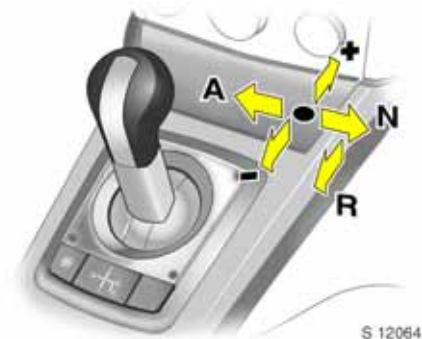

- + Shifting to a higher gear.
- Shifting to a lower gear.

If a higher gear is selected when the running speed is too low, or a lower gear when the speed is too high, no shift is effected. This prevents the engine from running at too low or too high revs.

Gears can be skipped by moving the selector lever repeatedly at short intervals.

If the vehicle is in Automatic mode, when the selector lever is moved to **+** or **-** Easytronic shifts to Manual mode and shifts up or down. The transmission display shows "M" and the currently selected gear.

Move selector lever towards R

Reverse gear. Engage only when vehicle is stationary.

Depress the footbrake, release the handbrake and move the selector lever to **R**. Reverse gear is engaged. "R" appears in the transmission display.

The vehicle begins to "creep" when the footbrake is released.

It is also possible to start-off in reverse without depressing the footbrake if the accelerator pedal is operated directly after movement of the selector lever. If there is no immediate acceleration or the footbrake is not depressed, no gear is engaged and "R" flashes. After several seconds the display reverts back to displaying "N". Then repeat the previously described start-off procedure.

Electronically controlled driving programmes

- By means of delayed gear changing (higher engine speeds) following a cold start, the operating temperature programme in Automatic mode quickly and automatically brings the catalytic converter to the temperature required for optimum pollutant reduction.
- Adaptive programmes automatically adapt gear shifting in Automatic mode to suit the driving conditions, such as if the vehicle is towing a caravan / trailer, has a high payload, or is being driven on inclines.



- When SPORT mode is engaged, shift times are reduced and the transmission shifts at higher engine speeds (unless cruise control is on). SPORT mode – see page 150.
- Winter programme: Press button – see next column.

Winter programme



In the event of difficulties starting-off on slippery roads, press button ("A", currently engaged gear and appear in the transmission display). Easytronic switches to Automatic mode and the vehicle starts-off in second gear.

The Winter programme is switched off by:

- pressing button again,
- turning off the ignition.

In order to protect the Easytronic, the Winter programme automatically switches itself off at extremely high clutch temperatures.

If the Winter programme is activated, SPORT mode is deactivated.

If the vehicle is switched to Manual mode while the Winter programme is active, the Winter programme is interrupted. The Winter programme resumes upon return to Automatic mode.

Kickdown

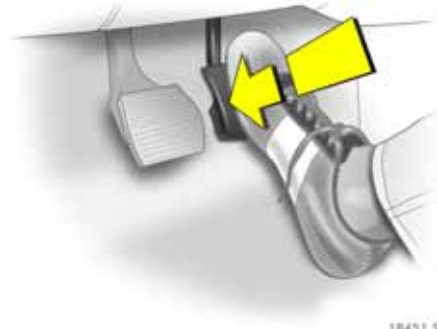

18451 S

Depressing the accelerator pedal past the pressure point: depending on the engine speed the transmission shifts to a lower gear. Full engine power is available for accelerating.

During kickdown no manual gear shifting is possible.

When the engine speed approaches its upper limit, the transmission shifts to a higher gear during kickdown even in Manual mode.

Without kickdown this automatic shift is not effected in Manual mode.

If SPORT mode is engaged, the drive wheels may spin slightly when starting-off with kickdown. This allows for maximum acceleration of the vehicle.

Engine braking Automatic mode

When driving downhill, Easytronic does not shift into higher gears until a fairly high engine speed has been reached. When braking, Easytronic shifts down in good time.

Manual mode

To utilise the engine braking effect, select a lower gear in good time when driving downhill.

"Rocking the vehicle"

If it becomes necessary to rock the vehicle to free it from sand, mud, snow or a hole, move the selector lever between **R** and **A** (or + or -) in a repeat pattern while applying light pressure to the accelerator pedal. Do not race the engine and avoid sudden acceleration.

This applies only to the exceptional circumstances mentioned above.

Manoeuvring the vehicle



18230 S

To manoeuvre the vehicle back and forth during attempts to park or in garage entrances the creeping movement can be utilised by releasing the footbrake.

Never actuate accelerator and brake pedals simultaneously.

To prevent damage, Easytronic disengages the "creep function" at excessively high automatic clutch temperatures.

Stopping the vehicle

In Automatic or Manual mode, when the vehicle has stopped first gear (with Winter mode engaged, second gear) is engaged automatically and the clutch released. In **R**, reverse remains engaged.

If the engine is running, a gear has been selected and the footbrake has not been depressed, a warning buzzer goes off when the driver's door is opened. If the handbrake has not been applied the vehicle starts to creep. Move selector lever to **N** and apply handbrake.

When stopping on gradients, engage the handbrake or depress the brake pedal. To prevent overheating of the clutch, do not increase engine speed to ensure smooth idling when in gear.

To prevent damage to the Easytronic, the clutch is closed automatically at high clutch temperatures.

Switch off engine if stopping for a lengthy period, e.g. in traffic jams or at level crossings.

Vehicle storage

Before leaving the vehicle:

- engage handbrake,
- remove the ignition key or, with the Open&Start system , remove the electronic key from the vehicle.

The most recently engaged gear (indicator in transmission display) remains engaged. With **N**, no gear is engaged.

When the ignition is switched off the Easytronic no longer responds to movement of the selector lever.

Lock the vehicle. Otherwise the battery may become discharged if the vehicle is parked for long periods.

If the handbrake has not been applied, the control indicator  flashes for a few seconds after the ignition is switched off.

With the engine off and the handbrake not applied, when the driver's door is opened a warning buzzer sounds and the control indicator  flashes; switch on ignition, engage gear, switch off ignition and apply handbrake.

Fault



Control indicator  illuminates in the event of a fault in the Easytronic system. In the event of serious faults, "F" also appears in the transmission display.

It is possible to continue driving if only control indicator  illuminates. Manual mode can then no longer be selected.

If "F" appears in the transmission display, continued driving is not possible.

Have the cause of the fault rectified by a workshop. Self-diagnosis integrated into the system facilitates rapid rectification of faults.

Interruption of power supply

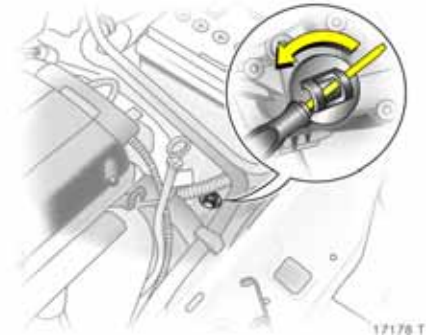

The clutch is not disengaged if the vehicle battery is discharged and a gear has been selected. The vehicle cannot move.

If the battery is flat, start the vehicle using jump leads – see page 171.

If the interruption of power supply is not due to the discharged battery, seek assistance from a workshop. If the vehicle has to be removed from the flow of traffic, release the clutch as follows:

1. Apply handbrake and switch off ignition.
2. Open and support the bonnet.

3. Clean Easytronic around the cap (see Fig. 17178 T on the previous page) so that no dirt can get into the opening when the cap is removed.
4. Rotate cap to slacken and remove by lifting upwards – see Fig. 17178 T on the previous page.
5. Turn the adjusting screw clockwise using a flat-head screwdriver (vehicle tools * – see page 174) until clear resistance can be felt. The clutch has now been disengaged.

Do not turn beyond the resistance, since this can damage the Easytronic.

6. Fit cleaned cap again. The cap must be in full contact with the housing.

Towing the vehicle and starting the engine is not permitted when the clutch has been released in this way, although the vehicle can be moved a short distance.

Seek the immediate assistance of a workshop.

Automatic transmission *

The automatic transmission makes automatic shifting possible (**Automatic mode**) and the version with ActiveSelect also makes manual shifting possible (**Manual mode**) *.

The engine can only be started in position **P** or **N**. When starting in position **N**, operate footbrake or apply handbrake. After starting the engine, operate brake before selecting a gear. Do not accelerate whilst selecting a gear. If a gear has been selected and the brake is released, the vehicle will "creep". Never operate the accelerator and the brake pedal simultaneously. The selected gear is displayed in the gear display – see Fig. 17022 T.

Warning

Disregard of these instructions may lead to injuries or endanger life.

Selecting **D** puts the transmission in Automatic mode.

In the version without ActiveSelect, only select **3**, **2** and **1** to avoid automatic upshifting or when using the engine to brake.

Moving the selector lever to the left in position **D** in the version with ActiveSelect activates Manual mode, and the gears can be selected manually by tapping the selector lever to + or -.

Transmission display



Display of mode or selected gear in left position of transmission display. The gear that has been selected by the transmission appears in the right position of the transmission display.

- P** Park position.
- R** Reverse gear.
- N** Neutral.
- D** Automatic mode.
- M** Manual mode * with display of selected gear.
- 3, 2, 1** Selected gear *.

Selector lever settings P, R, N and D (Automatic mode)



S 11558

- P** Park position. Front wheels locked. Only engage when the vehicle is stationary and the handbrake is applied. The transmission display shows "P".
- R** Reverse gear. Only engage when the vehicle is stationary. The transmission display shows "R".
- N** Neutral or idle. The transmission display shows "N".
- D** Drive position for normal driving in 1st gear to top gear. "D" and the current gear are shown in the transmission display.



S 11559

The selector lever can only be moved out of position **P** or **N** with the ignition switched on and the footbrake applied (selector lever lock). In selector lever position **N** the selector lever lock is activated after a delay and only if the vehicle is stationary.



S 11560

In positions **P** and **N** the control indicator illuminates (red) in the selector lever indicator strip if the selector lever is blocked.

To engage **P** or **R**, push button on selector lever.

The engine can only be started with lever in position **P** or **N**. When position **N** is selected, press footbrake or engage handbrake before starting.

Do not accelerate during the selection procedure.

Gears 3, 2, 1 *



S 11561

3, 2, 1 The transmission does not shift beyond the selected gear.

Press button on selector lever to engage **3** or **1**.

The current gear is displayed in the transmission display.

ActiveSelect (Manual mode) *



S 11562

Move selector lever out of position **D** towards the left and then forwards or backwards.

- + Shift to a higher gear
- Shift to a lower gear

If a higher gear is selected at a speed that is too slow or a lower gear is selected at a speed that is too high, the gear will not be changed. This prevents the revs from being too low or too high.

If the engine revs are too low the transmission automatically shifts to a lower gear, but not unless a certain speed has been reached.

No automatic shifting to a higher gear takes place at high engine revs.

For safety reasons, kickdown is also available in Manual mode – see page 139.

The selected gear is displayed in the transmission display – see page 136.

Electronically controlled driving programmes



17961 T

- When SPORT mode is engaged, the transmission shifts at higher engine speeds (unless cruise control is on). Control indicator illuminates in the transmission display. SPORT mode – see page 150.
- Winter programme: Press button – see page 139.
- Automatic neutral shift function automatically sets the transmission to **N** to reduce fuel consumption, e.g. at traffic lights.

The automatic neutral is activated when:

- the selector lever is in automatic or Manual mode ,
- the selector lever is in position **3**, **2** or **1** ,
- the footbrake is depressed,
- the vehicle is stationary,
- the accelerator pedal is not actuated,
- the transmission fluid temperature is greater than 0 °C.

As soon as the brake is released and the accelerator pedal is depressed, the vehicle starts off in the usual manner.

- The operating temperature programme automatically brings the catalytic converter to the temperature that is required for optimum emission reduction after a cold start by selecting an appropriate gear (increased engine revs).
- The adaptive programme automatically tailors gearshifting to the driving conditions, e.g. greater load or gradients.

Winter programme ❄️



S 11563

Press button ❄️ if you are having problems starting-off on a slippery road surface.

Activation in version without ActiveSelect

The Winter programme can be activated in **P, R, N, D, 3** (❄️ illuminates in the transmission display). The vehicle starts off in 2nd gear.

Activation in version with ActiveSelect

The Winter programme can be activated in Automatic mode (❄️ illuminates in the transmission display). The vehicle starts off in 2nd or 3rd gear, depending on the road conditions.

To deactivate

The Winter programme is switched off by:

- pressing button ❄️ again,
- shifting to **2** or **1** ❄️ manually,
- changing to Manual mode,
- turning off the ignition.

In order to prevent damage, the Winter programme switches off automatically at high transmission fluid temperatures.

Kickdown

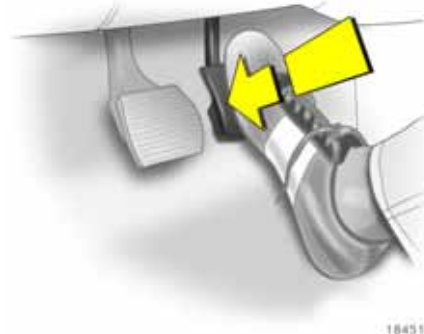

184515

Depressing the accelerator pedal past the pressure point: depending on the engine speed the transmission shifts to a lower gear. Full engine power is available for accelerating.

For safety reasons kickdown is available in both automatic and Manual mode.

Engine braking

Version without ActiveSelect

In order to utilize the engine braking effect when driving downhill, select gear **3**, **2** or, if necessary, **1** in good time.

The braking action is most effective in gear **1**. If gear **1** is selected at too high a speed, the transmission remains in second gear until the shift point for first gear is reached, e.g. as a result of deceleration.

Version with ActiveSelect

The automatic transmission automatically selects the driving programs with the best possible braking effect.

If necessary, lower gears can also be selected in Manual mode to increase the braking effect. 1st gear has the greatest braking effect.

"Rocking the vehicle"

If it becomes necessary to rock the vehicle to free it from sand, mud, snow or a hole, move the selector lever from **D** to **R** in a repeat pattern while simultaneously applying light pressure to the accelerator pedal. Do not race the engine and avoid sudden acceleration.

This applies only to the exceptional circumstances mentioned above.

Manoeuvring the vehicle

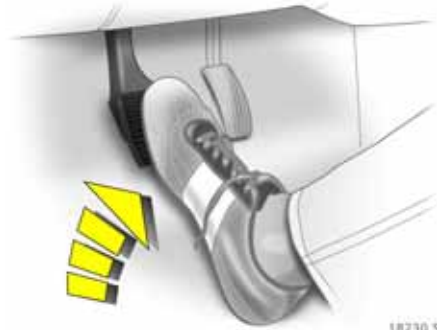

To manoeuvre the vehicle back and forth during attempts to park or in garage entrances, the vehicle's creeping movement can be utilised by releasing the brake pedal.

Never actuate an accelerator and brake pedals simultaneously.

Stopping the vehicle

The selector lever can be left in the chosen gear with the engine running.

When stopping on gradients engage handbrake or depress brake pedal. To prevent overheating of the transmission, do not increase engine revolutions to ensure smooth idling while standing if a gear has been selected.

Switch off engine if stopping for a lengthy period, e.g. in traffic jams or at level crossings.

Before leaving the vehicle, first apply the handbrake, then select **P**. Remove ignition key or with Open&Start system remove electronic key from the vehicle. Lock vehicle, otherwise battery may become discharged if vehicle is parked up for long periods.

The ignition key can only be removed when the selector lever is in position **P**.

If the selector lever is not in position **P** when the ignition is switched off, the control indicator  and **P** flash in the selector lever indicator strip – see page 137, Fig. S 11560, move selector lever to position **P**.

With the Open&Start system, "P" flashes in the transmission display for 10 seconds with the ignition switched off if **P** was not selected or the handbrake was not applied before switching the engine off.

Fault



If there is a problem with the automatic transmission, control indicator  illuminates. The transmission no longer shifts automatically. The vehicle can continue to be driven.

Illumination of control indicator  may also indicate a problem with the engine electronics – see page 147.

With diesel engines¹⁾ Z 19 DT, Z 19 DTH, illumination of control indicator  may also mean that the diesel fuel filter requires draining – see page 203.

Have the cause of the fault rectified by a workshop.

Version without ActiveSelect

2nd gear is unavailable. Selecting forward gears 1, 3 and 4 manually using the selector lever:

- 1 = 1st gear
- 2 = 3rd gear
- 3, D = 4th gear

Version with ActiveSelect

2nd gear and the highest gear can be selected in Manual mode. Depending on the nature of the problem, only the highest gear may be available.

Only the highest gear is available in **D** in Automatic mode.

¹⁾ Sales designation – see page 213.

Interruption of power supply



If the vehicle battery is flat, the selector lever cannot be moved out of position **P** or **N**.

If the battery is flat, start the vehicle using jump leads – see page 171.

If the battery is not the cause of the fault, release selector lever:

1. Apply handbrake.
2. Remove ashtray * – see page 79. Release screw on metal cover * and remove both parts. Vehicle toolkit – see page 174.
3. Unclip ashtray holder * or cover: to do this, reach into the opening at the top edge, unclip the ashtray holder * or cover and remove.



4. Pull loop and move selector lever out of position **P** or **N**.
5. Put on ashtray holder * or cover and engage.
6. Attach metal cover with screw. Insert ashtray * – see page 79.

Engaging **P** or **N** again effects locking once more. Have the cause of the interruption of power supply rectified by a workshop.

Driving hints

The first 600 miles (1000 km)

Drive your vehicle at various speeds. Do not use full throttle. Never allow the engine to labour at low revs.

Make good use of all gears. Depress the accelerator pedal a maximum of around three quarters of the available pedal travel in all gears.

Do not drive faster than three quarters of maximum speed.

Do not brake unnecessarily hard for the first 125 miles (200 km).

Never coast with engine not running
Many units will not function in this situation (e.g. brake servo unit, electro-hydraulic power-assisted steering). Driving in this manner is a danger to yourself and others.

Brake servo unit

When the engine is not running, the brake servo unit is no longer effective once the brake pedal has been depressed once or twice, braking effect is not reduced, but significantly greater force is required for braking.

Electro-hydraulic power-assisted steering

If the power-assisted steering fails when being towed with the engine switched off, the vehicle can still be steered, but considerably more force is required.

Driving in mountainous terrain or with a caravan / trailer

The cooling fan is electrically operated. Its cooling power is therefore independent of the engine speed.

Since a considerable amount of heat is generated at high engine speeds and less at slower speeds, do not shift down when climbing hills whilst the vehicle is still coping with the gradient in the higher gear.

Driving with a roof load

Do not exceed the permissible roof load – see pages 164, 217. For reasons of safety, distribute the load evenly and secure it properly with retaining straps. Adjust the tyre pressure to the load conditions. Do not drive faster than 75 mph (120 km/h). Check and retighten the straps frequently.

Observe country-specific regulations.

Switching off the engine

When you switch off the engine, fans in the engine compartment may continue running for a time to cool the engine.

If the engine temperature is very high, e.g. after driving in mountainous terrain: allow the engine to idle for approximately two minutes in order to prevent heat accumulation.

Vehicles with turbocharged engine *

After running at high engine speeds or high engine loads, operate the engine briefly at a low load or run in neutral for approx. 30 seconds before switching off in order to protect the turbocharger.

Save energy – more miles / kilometres

Please note the instructions for running in under "The first 600 miles (1000 km)" and the tips for saving energy on the next few pages.

Good, technically correct and economical driving ensures maximum durability and performance for your vehicle.

Overrun

The fuel supply is automatically shut off during overrun, e.g. when the vehicle is being driven down long gradients or when braking. To enable the overrun cut-off to take effect, do not accelerate during overrun and, if in manual transmission mode, do not declutch. To prevent damage to the catalytic converter, overrun cut-off is temporarily deactivated when the catalytic converter temperature is high.

Vehicles with turbocharged engine *

Flow-generated noises may be audible if the accelerator is released quickly on account of an airflow in the turbocharger.

Engine speed

Drive in a low engine speed range for each gear as much as possible.

Warming up

Run engine warm, do not warm up in idle. Do not apply full gas until the operating temperature has been reached.

After a cold start, the automatic transmission * or Easytronic * in Automatic mode shifts into higher gears at higher rpm. This allows the catalytic converter to quickly reach the temperature required for optimum pollutant reduction.

Correct gear selection

Do not race your engine while the transmission is in neutral or with a low gear selected. Stop-and-go traffic and driving at a speed too high for the selected gear or transmission ratio increases engine wear and fuel consumption.

Change down!

When decreasing speed, shift down into the next lowest gear. Do not slip the clutch with a high-revving engine. This is especially important when hill climbing.

Clutch operation

Always depress the clutch pedal hard to the floor to prevent shifting difficulties and transmission damage.

When driving, do not use the pedal as a footrest; this will cause substantial clutch wear.

Cooling fan

The cooling fan is controlled via a thermostat and therefore only runs if necessary.

Depending on the engine, the cooling fan comes on automatically when the diesel particle filter * is being cleaned.

Pedals

Do not place any objects in the footwell which could slip under the pedals and inhibit the pedal travel.

To ensure the pedal travel is uninhibited, there must be no mats in the area of the pedals.

Battery care

When driving slowly or when the vehicle is stationary, e.g. in slow urban traffic, stop-and-go traffic or traffic jams, turn off all unnecessary electrical loads where possible (e.g. heated rear window, heated seats).

Declutch when starting in order to relieve the strain on the starter and the battery.

Saving fuel, protecting the environment

Trend-setting technology

When developing and manufacturing your vehicle, Vauxhall used environment-friendly and in the main recyclable materials. The production methods used to make your vehicle are likewise environmentally-compatible.

Recycling of production wastes keeps the circulation of material closed. Reduction of energy and water requirements also helps to conserve natural resources.

The advanced design makes it easier to dismantle the vehicle at the end of its service life and separate materials for recycling.

Materials such as asbestos and cadmium are not used. The refrigerant in the air conditioning system * is CFC-free.

New painting techniques employ water as a solvent.

End-of-life vehicle recovery

For detailed information on Vauxhall's on-going commitment to achieving an environmentally sustainable future, including design for recycling, take back of End-of-Life Vehicles (ELVs) and the recycling of ELVs, view www.vauxhall.co.uk/recycling for details.

Drive in an energy and environment-conscious way

■ High fuel consumption, noise levels and exhaust emission are often caused by a driving style that is not energy and environment-conscious.

■ You should therefore drive with energy in mind: "more miles with less fuel".

Reduce the noise level and exhaust emissions by adopting an environment-conscious driving style. This is extremely worthwhile and improves the quality of life.

Fuel consumption depends to a great extent on your own personal driving style. The following hints are intended to help you consume fuel at a rate that is as close as possible to the specified levels – see page 215.

Check your vehicle's fuel consumption every time you refuel. This facilitates early detection of any irregularities causing increased fuel consumption.

Warming up

■ Full throttle and warming up at idle speed increase wear, fuel consumption, exhaust emission, the amount of pollutant in the exhaust and the amount of noise.

■ Drive off as soon as possible after starting.

Uniform speed

■ Hectic driving significantly increases fuel consumption, the exhaust emissions, the proportion of pollutant in the exhaust gas and the noise level.

■ Do not accelerate and brake unnecessarily. Drive at uniform speed.

Avoid frequent starting-off and stopping e.g. at traffic lights, in short distance traffic and in queues of traffic by means of clever planning. Select roads with good traffic flow.

Idling

■ The engine also consumes fuel when idling.

■ If you have to wait for more than one minute, it is worthwhile switching off the engine. Five minutes of idling corresponds to approx. 0.6 miles (1 km) of driving.

Overrun

■ The fuel supply is automatically shut off during overrun, e.g. when the vehicle is being driven down long gradients or when braking – see page 142.

■ To enable the overrun cut-off to take effect and save fuel, during overrun do not accelerate and do not declutch.

■ Correct gear selection.

■ High revs increase engine wear and fuel consumption.

■ Do not race your engine. Avoid driving at high engine speeds.

Driving with an eye on the tachometer saves fuel. If possible, drive at low revs in each gear and at a constant speed.

Drive in top gear as much as possible, shift up as soon as possible and do not shift down until the engine is no longer running truly.

High speed

■ The faster the speed, the higher the consumption and the noise level. Driving at full throttle uses up a great deal of fuel and generates excessive noise and high emission levels.

■ Slightly releasing the accelerator pedal results in distinct fuel savings with no major loss of speed.

Drive at no more than around three quarters of maximum speed and you will use up to 50% less fuel, without losing a great deal of time.

Tyre pressure

■ Inadequate tyre pressure, leading to higher road resistance, costs money in two ways: more fuel and increased tyre wear.

■ Regular checks (every 14 days) pay off.

Electrical loads

■ The power consumption of electrical equipment increases fuel consumption.

■ Switch off additional consumers (e.g. air conditioning ✱, heated rear window) when they are no longer required.

Roof racks, ski-holders

■ Due to air resistance, a roof load can increase fuel consumption by approx. 3.5 gal./1000 miles (1 l/100km).

■ Remove them if they are not being used.

Repair and maintenance

■ Improper repairs or an adjustment and maintenance work can increase fuel consumption. Do not carry out work on the engine yourself.

You may infringe environmental laws out of ignorance by not disposing of materials properly.

Appropriate parts might not be recycled.

Contact with some of the materials involved may pose a health hazard.

■ We recommend that repair and maintenance be entrusted to your Vauxhall Authorised Repairer.

Extreme driving conditions

■ Driving up steep gradients, cornering, driving on poor roads and winter driving all increase fuel consumption.

Fuel consumption increases dramatically in urban traffic and at winter temperatures, especially on short trips when the engine operating temperature is not reached.

■ Follow the hints given above to keep consumption to a minimum under such conditions.

Fuel consumption, fuel, refuelling

Fuel consumption

Fuel consumption is determined under specific driving conditions – see page 215.

Special equipment increases the weight of the vehicle. As a result, they can increase fuel consumption and reduce the specified maximum speed.

For the first few thousand miles / kilometres, friction between the engine and transmission components is higher. This increases fuel consumption.

Fuel for petrol engines

Normal commercial high-quality fuels with a maximum ethanol content of 5% in accordance with DIN EN 228 are suitable (for catalytic converter – see page 146, for octane numbers – see pages 212, 213). The quality thereof has considerable effect on the performance, running and service life of the engine. The additives mixed with the fuel are extremely important. For this reason you must only refuel with high-quality fuels containing additives.

Fuels with ethanol content greater than 5% do not comply with DIN EN 228 and must not be used unless the vehicle has been specifically developed and approved for these fuels.

Fuel with too low an octane rating can cause pinking. No liability will be accepted for resulting damage.

Petrol with a higher octane number can always be used.

The use of 91 octane fuel is not permitted in vehicles with the Z 22 YH¹⁾ engine.

The ignition timing adjusts automatically to the grade of fuel used (octane number) – see pages 212, 213.

Use of petrol with an octane rating of 95 will ensure economical driving.

For vehicles with Z 20 LEH¹⁾ engine, use of 95 RON fuel reduces performance and torque.

Fuel for diesel engines

Diesel engines must be operated only on commercially available diesel fuel meeting the specifications of DIN EN 590.

Since January 2004, some oil companies have mixed their diesel fuel with up to 5% Bio fuel (FAME = Fatty Acid Methyl Esters) like RME (Rape-Oil Methyl Ester). This is in accordance with the current DIN EN 590 and does not harm the fuel injection system. The characteristics of a diesel fuel mixed up with 5% Bio fuel (FAME) do not differ from conventional diesel fuel and do not influence the vehicle's driveability.

Important: Diesel fuel mixed with 5% FAME according to DIN EN 590 must not be confused with 100% Bio Diesel, which is not to be used in Vauxhall engines.

The flow and filterability of diesel fuel are temperature-dependent.

¹⁾ Sales designation – see page 212.

Diesel fuels with improved low temperature properties are therefore available on the market during the winter months.

Make sure that you fill the tank with winter fuel before the start of the cold weather season.

Additives can be used with diesel fuels with winter properties that are guaranteed by the manufacturer and when using diesel fuel filters that are heated depending on the outside temperature.

Diesel fuels must not be diluted with fuels that are intended for petrol engines.

Fuel filler cap

If replacing the fuel filler cap, be sure to use a genuine fuel filler cap for your model to ensure full functionality. Diesel-engined vehicles have special fuel filler caps.

Refuelling



17192 T

Warning

Care must be taken when handling fuel.

Before refuelling, switch off the engine and where applicable any auxiliary heating with combustion chambers (see sticker on fuel filler cap). Switch off mobile phones.

Warning

Fuel is inflammable and explosive. Therefore, when handling fuel or when in the vicinity of fuel, avoid naked flames and sparks. Do not smoke! This also applies where fuel can be detected by its characteristic smell. If you can smell fuel in your vehicle, have the cause of this rectified immediately by a workshop.

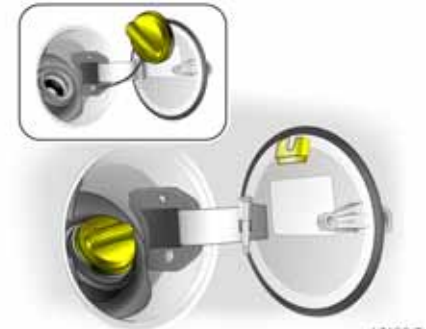

17198 T

Fuel filler neck at right rear side of vehicle.

The tank flap is locked together with the doors – see page 37.

Open the tank flap.

Unscrew the fuel filler cap, remove and suspend from the tank flap.

The fuel tank has a limiting system which prevents overfilling of the tank.

Correct filling depends to a large extent on proper operation of the fuel dispensing pump:

1. Fully insert the pump nozzle and switch it on.
2. At automatic switch off, the specified tank capacity is reached after continued, measured filling. Leave the filler nozzle in place until the flow stops.

To close, place fuel filler cap in position and turn, overcoming the resistance until the ratchet on the cap engages audibly.

Close tank flap.

Wipe off any overflowing fuel immediately.

Catalytic converter, exhaust gases Catalytic converter for petrol engines

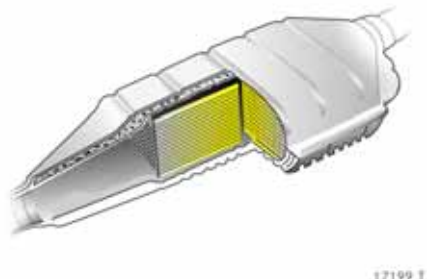

Leaded fuel will damage the catalytic converter and parts of the electronic system, rendering them inoperative.

High quality fuels other than those listed on pages 144, 212 (e.g. LRP¹⁾) could damage the catalytic converter.

Damage to the catalytic converter or the vehicle may result if the following points are not observed:



- In the event of faulty ignition, uneven running after cold starting, clear reduction in engine performance or other unusual problems which may point to a fault in the ignition system, seek assistance of a workshop as soon as

possible. Continue emergency driving for a short period, maintaining low speed and revs.

Irregular engine running and lack of power when the Electronic Stability Programme (ESP[®] Plus ) kicks in are for operational reasons and can be ignored – see page 148.

- If unburned fuel enters the catalytic converter, this may result in overheating and irreparable damage to the catalytic converter.

You should therefore avoid unnecessarily long use of the starter when starting-off, running the tank dry (an irregular fuel supply will lead to overheating) and starting the engine by pushing or towing.

- If the control indicator  for exhaust flashes, ease back on the accelerator until the flashing stops and the control indicator comes on. Seek the immediate assistance of a workshop. Control indicator  for exhaust – see page 147.

Catalytic converter for diesel engines

Damage to the catalytic converter or the vehicle may result if the following points are not observed:

- In the event of uneven running, a clear reduction in engine performance or other unusual problems, seek the assistance of a workshop as soon as possible. Continue emergency driving for a short period, maintaining low speed and revs.

¹⁾ LRP = Lead Replacement Petrol.

Irregular engine running and lack of power when the Electronic Stability Programme (ESP®Plus) kicks in are for operational reasons and can be ignored – see page 148.

Controlling exhaust emission



Design measures – mainly in the area of the injection system and ignition system, in combination with the catalytic converter – have reduced the proportion of harmful substances in the exhaust gases, such as carbon monoxide (CO), hydrocarbons (CH) and nitrous oxides (NO_x), to a minimum.

Control indicator for exhaust



Illuminates when the ignition is switched on and during the start attempt. Goes off shortly after the engine starts running.

If it illuminates while the engine is running, it indicates a fault in the emission control system. The permitted exhaust values may be exceeded. Seek the immediate assistance of a workshop.

If it flashes while the engine is running, this indicates a fault which could lead to damage to the catalytic converter. Continuing to drive without causing damage is possible if you ease up on the throttle until the flashing stops and the control indicator illuminates. Seek the immediate assistance of a workshop.

Control indicator for engine electronics





Illuminates for several seconds when the ignition is switched on.

If it illuminates when the engine is running, there is a fault in engine or transmission electronics. The electronic system switches to an emergency running programme. Fuel consumption may be increased and the driveability of the vehicle may be impaired.

In some cases, faults can be rectified by switching off the engine and restarting it. If the control indicator illuminates again when the engine is running, seek the assistance of a workshop to rectify the cause of the fault.

If it illuminates briefly, but does not recur, it is of no significance.

If  illuminates, this may also indicate that water is present in the diesel fuel filter . At the same time, a text message

appears in the service display – see page 88. Have the diesel fuel filter checked for any residual water – see page 203.

If it flashes after the ignition is switched on, there is a fault in the immobiliser system.

The engine cannot be started – see page 30.

Exhaust gases

Warning

Engine exhaust gases contain poisonous carbon monoxide, which is colourless and odourless and could be fatal if inhaled.

If exhaust gases enter the interior of the vehicle, open the windows and seek the assistance of a workshop.

Avoid driving with an open luggage compartment. Otherwise, exhaust gases could penetrate the interior.

During the first drive, smoke may develop because of wax and oil evaporating on the exhaust system. Park the vehicle in the open for a while after the first drive and avoid inhaling the fumes.

Diesel particle filter *

The diesel particle filter system filters harmful soot particles out of the exhaust gases.

The system includes a self-cleaning function at set intervals. The filter is cleaned by burning off the soot particles at high temperature. This process takes place

automatically under set driving conditions and may take up to 25 minutes. Fuel consumption may be higher during this period. The emission of smells and smoke thus occurring is normal.

Under certain driving conditions, e.g. short distances, the system cannot clean itself automatically.

When the control indicator  flashes, you should continue driving and as soon as the road and traffic conditions so permit, increase your speed to over 25 mph (40 km/h); cleaning of the diesel particle filter will then commence. Cleaning takes place most quickly at high speed and under load. The engine speed should not fall below 2000 rpm. The control indicator will go out as soon as cleaning is complete.

We recommend that you do not turn off the ignition during cleaning.

Maintenance

Have all maintenance work carried out at the intervals specified. We recommend that you entrust this work to your Vauxhall Authorised Repairer, who has proper equipment and trained personnel available. Electronic testing systems facilitate rapid diagnosis and remedy of faults. This way you can be certain that all components of the vehicle's electrical, injection and ignition systems operate correctly, that your vehicle has a low level of pollutant emission and that the catalytic converter system will have a long service life.

You are thereby making an important contribution towards keeping the air clean and compliance with emissions legislation.

The Service work includes testing and adjusting the fuel injection system and the ignition system. For this reason, have all Service work carried out at the intervals specified in the Service Booklet.

Drive Control Systems

IDS+ = Interactive Driving System *

The IDS+ links the sensors and control units of the Electronic Stability Programme (ESP^{Plus}), the Anti-lock Brake System (ABS) and the Continuous Damping Control (CDC). This gives excellent driving dynamics at the same time as high safety levels.

Electronic Stability Programme (ESP^{Plus}) *

ESP^{Plus} improves driving stability when necessary in any driving situation regardless of the type of road surface or tyre grip. It also prevents the drive wheels from spinning, irrespective of road surface type and tyre grip.

The system monitors vehicle movements. As soon as the vehicle starts to swerve (understeers/ oversteers) engine output is reduced (the sound of the engine changes) and individual wheels are specifically braked. This considerably improves the driving stability of the vehicle on snow and ice and on wet or slippery road surfaces.

ESP®Plus is ready for operation as soon as the ignition is switched on and control indicator  goes out.

The ESP®Plus control process is displayed by the flashing of .

The vehicle is now in a critical situation; ESP®Plus allows you to keep control of the vehicle and reminds you to match your speed to the road conditions.

 **Warning**

Do not let this special safety feature tempt you into taking risks when driving.

Traffic safety can only be achieved by adopting a responsible driving style.

Control indicator 



17200 T

Illuminates for a few seconds when the ignition is switched on. The system is now ready for operation.

Flashing during driving:

This shows the system has come into action. The engine output may be reduced (the sound of the engine changes) and the vehicle may be braked automatically to a small degree.



Illuminates whilst driving:

The system is switched off or a fault is present. Continued driving is possible.

The driving stability can however deteriorate depending on road surface conditions.

Switch on ESP®Plus again or have the cause of the fault rectified. Self-diagnosis integrated into the system facilitates rapid rectification of faults.

Switching off 

ESP®Plus can be deactivated if SPORT mode  is engaged (LED in SPORT button illuminates) for high performance driving: Hold the SPORT button down for around 4 seconds, the control indicator  comes on. The service display also shows ESPoff – see page 88.

 **Warning**

ESP®Plus should not be deactivated if one of the run-flat tyres  has no pressure.



17961 T

ESP®Plus is reactivated by pressing the SPORT button again or switching on the ignition.

SPORT mode – see page 150.

CDC (Continuous Damping Control) *

CDC adapts vehicle damping to the current driving situation and road conditions.

The system continually monitors wheel and vehicle movements and immediately modifies the damping of each shock absorber. Chassis calibration is optimally adapted to the driving situation and road conditions.

When SPORT mode is engaged, the damping control is adapted to a sportier driving style ("harder" chassis setting).

SPORT mode – see right column.

Control indicator IDS+ for Continuous Damping Control



Illuminates for approx. 10 seconds when the driver's door is opened. If it illuminates whilst driving, this indicates a fault in the system. The system is not operational. The system switches to the harder chassis setting for reasons of safety. Have the

cause of the fault rectified by a workshop. Self-diagnosis integrated into the system facilitates rapid rectification of faults.

Sport mode *

SPORT mode is used to change damping *, steering *, throttle application * and the shifting point for automatic transmission * and Easytronic * whilst driving.

Damping and steering become more direct and provide better contact with the road surface. The engine reacts more quickly to accelerator movements.

With automatic transmission * and Easytronic *, shifting times are reduced and gearshifting occurs at higher engine speeds (unless cruise control is on).

To activate



Press the **SPORT** button. The LED in the button illuminates.

In vehicles with Automatic transmission * or Easytronic *, the control indicator * also illuminates.

SPORT mode cannot be switched on if the Winter programme * is active (vehicles with automatic transmission * or Easytronic *). For Winter programme – see page 139.

To deactivate

Briefly press the **SPORT** button again or switch off the ignition. The LED in the button goes out.

Holding it pressed switches off ESP®Plus – see page 149. SPORT mode remains engaged.

SPORT mode is switched off when the Winter programme * is activated (vehicles with automatic transmission * or Easytronic *). Winter programme – see page 139.

Control indicator IDS+ for SPORT mode





17201 T

Illuminates for approx. 10 seconds when the driver's door is opened. If it illuminates whilst driving, this indicates a fault in the system. The system is not operational. Have the cause of the fault rectified by a workshop. Self-diagnosis integrated into the system facilitates rapid rectification of faults.

Cruise control *

The cruise control can store and maintain speeds of approx. 20 to 125 mph (30 to 200 km/h). Deviations from the stored speeds may occur when driving uphill or downhill.

For safety reasons the cruise control cannot be activated until the footbrake has been operated once.

Cruise control is operated with buttons , , and  on the turn signal stalk.

Do not use the cruise control if it is not advisable to maintain a constant speed (e.g. in situations presenting a danger to yourself and other road users, in heavy traffic or on winding, slippery or greasy roads).

The cruise control must only be switched on in Automatic mode with automatic transmission * and Easytronic *.

When the cruise control is active, reaction times may be increased due to the different position of the feet.

Warning

The driver is also responsible for maintaining an appropriate speed if the cruise control is on. Failure to follow instructions can cause injuries or put lives at risk.

Control indicator 



17202 T

When driving, control indicator  will illuminate as soon as the system is switched on.

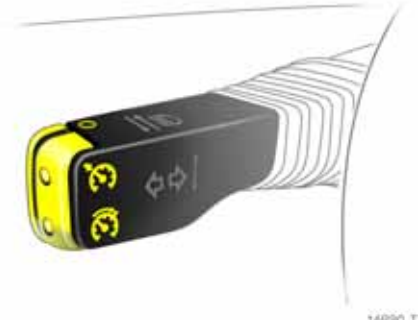

16990 T

To activate

Briefly press button : the current speed is stored and maintained. The accelerator pedal can be released.

Vehicle speed can be increased by depressing the accelerator pedal. When the accelerator pedal is released, the previously stored speed is resumed.

Increase

With cruise control active, hold down button  or briefly press it repeatedly: speed is increased continuously or in steps of 1.2 mph (2 km/h) without using the accelerator pedal.



When button  is released the current speed is stored and maintained.

Reduce

With cruise control active, hold down button  or briefly press it repeatedly: speed is reduced continuously or in steps of 1.2 mph (2 km/h).

When button  is released the current speed is stored and maintained.

To deactivate

Briefly press button : Cruise control is switched off, control indicator  goes out and the vehicle slowly decelerates. To continue driving, depress the accelerator pedal in the usual manner.

For reasons of safety, cruise control deactivates under certain driving conditions.

For example:

- if the vehicle's speed drops below approx. 20 mph (30 km/h) or
- if the brake pedal is depressed or

- if the clutch pedal is depressed or
- if the selector lever of automatic transmission * or Easytronic * is in N.

Resuming the stored speed

Briefly press button  at a speed above 20 mph (30 km/h): the speed selected before the cruise control was switched off is resumed.

The value of the stored speed is deleted when the ignition is turned off.

Parking distance sensors *



17447 T

The parking distance sensors make reverse parking easier by measuring the distance between the vehicle and an obstacle at the front and the rear, and emitting an acoustic signal in the passenger compartment.

The system records the distance using four sensors in the front and rear bumpers.



17448 T

To activate

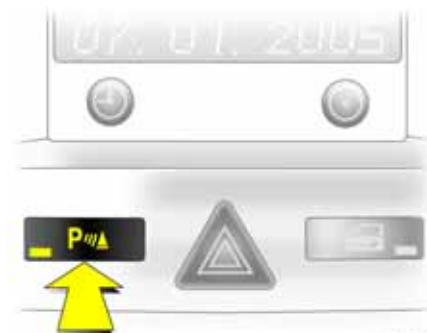

17016 T

If the ignition is on, the front and rear parking distance sensors automatically come on when reverse gear is selected.

The parking distance sensors can also be enabled manually at a speed of less than 15 mph (25 km/h) using the **P** button on the instrument panel.

Function standby is indicated by an illuminated LED in the button **P**.

If the vehicle approaches an obstacle at the front or the rear, a series of acoustic signals is heard in the vehicle interior. The interval between the signals becomes shorter as the obstacle becomes closer. The signal is continuous if the distance is less than 30 cm.

Warning

Under certain circumstances, various reflective surfaces on objects or clothing as well as external noise sources may cause the system to fail to detect obstacles. For this reason, care must be taken when reversing even if the parking distance sensors are operational. This is of particular importance when in the vicinity of pedestrians.

To deactivate

To switch the system off, press **P** button, and LED in button will go off.

The system automatically switches itself off when the vehicle is being driven forwards with a speed above approx. 15 mph (25 km/h).

Control indicator **P**



17204 T

If it illuminates:

Fault in the system. The system is not operational. Have the cause of the fault rectified by a workshop. Self-diagnosis integrated into the system facilitates rapid rectification of faults.

If it flashes:

The fault is due to sensors obstructed with snow or ice. The sensors must be undamaged and free of dirt, snow and ice.

Interference due to external sources of ultra sound (e.g. pneumatic drills, rotary machines). Once the source of interference is removed, the system will operate normally.

Caravan / trailer towing equipment*, caravan / trailer towing

The system automatically detects if a towbar is properly fitted to the vehicle.

In trailer mode, the rear parking distance sensors are automatically switched off when the trailer cable is inserted into the socket.

Fitting rear load racks*

Rear load racks, e.g. bicycle racks, fitted near the sensors could disrupt the system.

Automatic level control*



17449 T

Automatic level control makes it possible to keep the height of the vehicle constant when subjected to different loads in the rear (e.g. when towing a caravan or trailer). This significantly improves driving conditions.

The vehicle is automatically raised at the rear, increasing the spring travel and ground clearance.

The automatic level control system is activated after approx. 2 miles (3 km), depending on the vehicle loading and the nature of the road surface.

Headlight range adjustment – see page 107.

Do not use full payload in the event of a malfunction. Have the cause of the fault rectified immediately by a workshop.

Tyre pressure loss monitoring system DDS (Deflation Detection System) *

The Deflation Detection System continuously monitors the speed of all wheels whilst driving. If a tyre loses pressure, it becomes smaller and rotates more quickly than the other wheels. If the system detects a difference in speed, control indicator  illuminates red.

Stop immediately and check tyre pressure. Mount the spare wheel if necessary – see pages 175, 176.

The system is operational when the ignition is switched on and can detect pressure loss from a speed of 20 mph (30 km/h).

Control indicator



17018 T

If control indicator  illuminates red whilst driving, there is a loss of pressure. Stop immediately and check tyre pressures. A maximum speed of 50 mph (80 km/h) is permitted for run-flat tyres *. Observe the information on page 163.

If control indicator  illuminates yellow whilst driving, this indicates a fault in the system. Have the cause of the fault rectified by a workshop. Self-diagnosis integrated into the system facilitates rapid rectification of faults.

The control indicator flashes three times when the system is initialising.

Warning

The Deflation Detection System does not replace manual checks with a suitable gauge.

Check tyre pressures at least every 14 days and prior to any long journey; the tyres should be checked when cold. Don't forget to check the spare *.

Tyre pressure – see pages 160, 220.

System initialisation

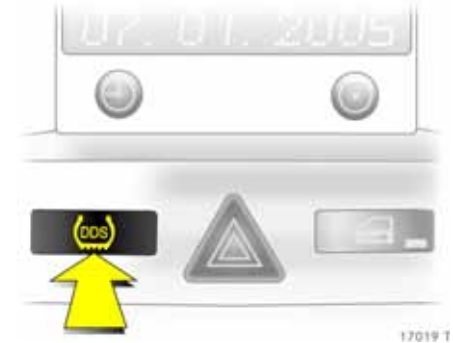

17019 T

After correcting tyre pressure or changing a tyre / wheel, the system must be initialised: With the ignition switched on, press the **DDS** button for approx. 4 seconds. Control indicator  flashes 3 times. The system is operational after driving a certain distance.

Only initialise the system if all tyres have the prescribed pressure.

Tyre Pressure Monitoring System ❄

The Tyre Pressure Monitoring System continually checks the pressure and speed of all four wheels whilst driving.

A pressure sensor is integrated in each wheel. Once a minute, the pressure of each tyre is sent to a control unit, where it is compared. If the system detects one or more pressure differences, a message appears on the information display.

The current tyre pressures are indicated in the information display.

For the system to be operational, all wheels must be equipped with pressure sensors and all tyres must be filled to the prescribed pressure. The Tyre Pressure Monitoring System automatically detects if the vehicle is being driven with a load of up to 3 persons or a full load.

Once the ignition is switched on, the system is operational and will continuously monitor the tyre pressures at speeds of approx. 20 mph (30 km/h) and above.

Warning

The Tyre Pressure Monitoring System does not replace manual checks with a suitable gauge.

Check tyre pressures at least every 14 days and prior to any long journey; the tyres should be checked when cold. Don't forget to check the spare ❄.

Tyre pressure – see pages 160, 220.

Display of current tyre pressure

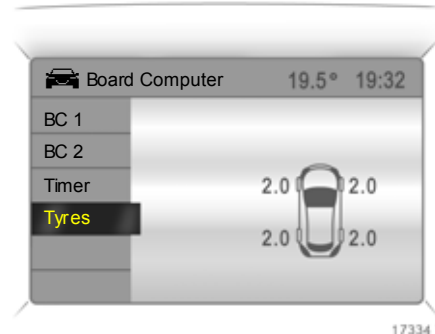

Select menu item **Tyres** from the **Board Computer** menu.

The current pressure of each tyre is displayed.

Warning messages

A message is given on the information display to warn of inconsistent tyre pressures. In some versions, the message is displayed in abbreviated form.

For example, the following messages can be displayed:



A graphic indicating the left rear tyre is shown together with the current tyre pressure: Slight pressure deviation. Reduce speed. Check pressure at next opportunity with appropriate gauge and correct if necessary.

On the Colour Information Display this report will appear in yellow.



A graphic indicating the front left tyre is shown together with the current tyre pressure: Significant pressure deviation or direct pressure loss. Steer out of flow of traffic as quickly as possible without endangering other vehicles. Stop and check the tyres.

Mount the spare wheel * if necessary – see pages 175, 176. A maximum speed of 50 mph (80 km/h) is permitted for run-flat tyres *. Observe the information on page 163.

On the Colour Information Display this report will appear in red.

Acknowledgement of warnings – see page 101.

Control indicator



If control indicator  illuminates yellow whilst driving, this indicates a fault in the Tyre Pressure Monitoring System. Fitting a wheel without a pressure sensor (e.g. spare wheel *) will also lead to a system fault. Have the cause of the fault rectified by a workshop. Self-diagnosis integrated into the system facilitates rapid rectification of faults.

System initialisation

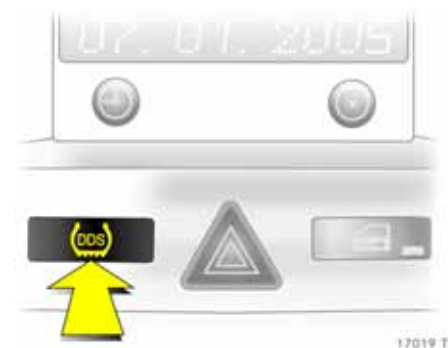

The system must be initialised after a wheel / tyre change:

With the ignition switched on, press button **DDS** for approx. 4 seconds. Control indicator  flashes 3 times. The system is operational after driving a certain distance.

Only initialise the system if all tyres have the prescribed pressure (check when tyres are cold).

General information

The Tyre Pressure Monitoring System is not operational when the temporary spare wheel or spare wheel is used if this is not fitted with a pressure sensor, the control indicator  illuminates yellow. When displaying the tyre pressure, -- appears in the display. The tyre pressure is then monitored by the Deflation Detection System – see page 154.

If a complete set of wheels without Tyre Pressure Monitoring System * sensors is mounted (e.g. four winter tyres), no error message will be displayed. The Tyre Pressure Monitoring System is not operational. The tyre pressure of a set of wheels without sensors is monitored by the Deflation Detection System – see page 154.

Sensors for the Tyre Pressure Monitoring System can be fitted at a later date by a workshop upon request.

When manually checking tyre pressure with a pressure gauge, screw the adapter onto the valve. Tyre pressure – see pages 160, 220.

Every time you change a tyre, the valve inserts and sealing rings from the Tyre Pressure Monitoring System must be replaced by a workshop.

The use of commercially available liquid filled run-flat systems or repair kits can impair the function of the system. Vauxhall-approved systems can be used.

Radio transmitters (e.g. radio headphones, walkie-talkies) operated in the area could cause interference in the Tyre Pressure Monitoring System.

Brake system

The effectiveness of the brakes is an important factor for traffic safety.

To improve effectiveness, do not brake unnecessarily hard for the first 125 miles (200 km) after new brake pads have been fitted.

Brake pad wear must not exceed a specified limit. Regular maintenance as detailed in the Service Booklet is therefore of the utmost importance for traffic safety.

Have worn brake pads replaced by a workshop.

Pads which have been tested and passed ensure optimum brake performance.

Brake pads worn to their minimum are noisy. It is possible to continue driving. Have your brake pads replaced as soon as possible. Seek the assistance of a workshop for replacing the brake pads.

Brake assist

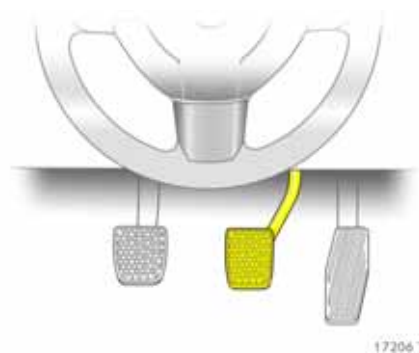

17206 T

Powerful application of the brake pedal automatically applies maximum braking force amplification to achieve the shortest possible braking distance under full braking (brake assist).

Maintain steady pressure on the brake pedal for as long as full-on braking is to continue. When the brake pedal is released, the maximum brake force amplification is taken away.

Adaptive brake light *

During full-on braking, all three brake lights flash for the duration of ABS control.

Footbrake

The footbrake comprises two independent brake circuits.

If a brake circuit fails, the vehicle can still be braked using the other brake circuit. However, braking effect is achieved only when you depress the pedal firmly. You need to use considerably more force for this. The braking distance is extended. Seek the assistance of a workshop before continuing your journey.

To ensure the full pedal travel can be utilized, especially in case of a fault in one of the brake circuits, there must be no mats in the vicinity of the pedals – see page 142.

When the engine is not running, the assistance of the brake servo unit disappears once the brake pedal has been depressed once or twice. Braking effect is not reduced, but braking requires significantly greater force. This is especially important to bear in mind when towing.

Check the brake lights before starting out on a journey. On vehicles with check control ✱ the brake lights are checked automatically – see page 101.

Just before starting any journey, check effectiveness of brake system at slow speed and without obstructing moving traffic, particularly if brakes are wet, e.g. after driving through an automatic car wash.

The brake fluid level should be checked regularly. If the brake fluid level is too low and the handbrake is not applied, control indicator (C) on the instrument cluster illuminates – see page 84.

Hill Start Assist ✱ (HSA)

The system helps pull away on inclines. After releasing the footbrake, if the handbrake is not applied the brakes are only released after 2 seconds. As soon as the acceleration is sufficient to prevent rolling back, the brake is released.

Handbrake

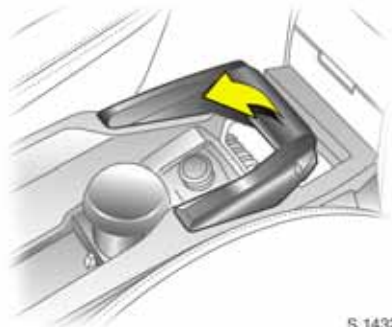

S 14326

Always apply handbrake firmly. On slopes apply the handbrake as firmly as possible.

The mechanical handbrake affects the rear wheel brakes. They automatically engage when the lever is pulled.

To release the handbrake, lift handle slightly, press release button and lower handle all the way down.

To reduce the operating forces of the handbrake, depress the footbrake at the same time.

Brake system control indicator (C)



17208 T

The control indicator illuminates when the ignition is switched on if the handbrake is applied or if the brake or clutch fluid level is too low. Brake fluid – see page 205.

For vehicles with Easytronic ✱, the control indicator flashes for a few seconds when the ignition is turned off if the handbrake is not applied.

⚠ Warning

If the control indicator comes on when the handbrake is off, stop, terminate your journey immediately. Seek the assistance of a workshop.

Anti-lock Brake System (ABS)

The ABS continuously monitors the brake system and prevents the wheels from locking, independently of the type of road surface and the tyre grip.

It starts to regulate the braking pressure as soon as a wheel shows a tendency to lock. The vehicle remains steerable, even in the event of very heavy braking, for instance on bends or when swerving to avoid an obstacle. Even in the case of full-on braking, the ABS makes it possible to drive round an obstacle without releasing the brakes.

ABS control is made apparent through a pulse in the brake pedal and the noise of the regulation process.

Warning

For optimum braking, keep the brake pedal fully depressed throughout the braking process, despite the fact that the pedal is pulsating. Do not reduce the pressure on the pedal.

Do not let this special safety feature tempt you into taking risks when driving.

Traffic safety can only be achieved by adopting a responsible driving style.

Control indicator for ABS



Illuminates for a few seconds after the ignition is turned on. The system is ready for operation when the control indicator goes out.

If the control indicator does not go out after a few seconds, or if it illuminates whilst driving, there is a fault in the ABS. The brake system remains operational without ABS regulation.

Self-check

Each time the ignition is turned on and the engine started, after moving away from a speed of around 2 mph (3 km/h) the system performs a self-check which may be audible.

Fault

Warning

If there is a fault in ABS, the wheels may be subject to locking due to braking that is heavier than normal. The advantages of ABS are no longer operational.

You can continue driving, provided you drive with care and anticipation.

Have the cause of the fault rectified by a workshop. Self-diagnosis integrated into the system facilitates rapid rectification of faults.

Wheels, tyres

See page 220 for suitable tyres and restrictions.

Factory-fitted tyres are matched to the chassis and offer optimum driving comfort and safety.

Changing tyre / wheel type

Note the necessary modifications before switching to different tyres or wheels.

If tyres of a different size than those fitted at the factory are used, the electronic speedometer may require reprogramming to ensure that the correct speed is displayed.

Warning

Use of unsuitable tyres or wheels may lead to accidents and render the vehicle unroadworthy.

Vehicles with Tyre Pressure Monitoring System *

When using winter tyres or when switching to different tyre sizes, sensors for the Tyre Pressure Monitoring System can be fitted at a later date by a workshop upon request. Otherwise, the system would not indicate tyre pressure deviations.

Deflation Detection System * – see page 154.

Tyre Pressure Monitoring System * – see page 155.

Vehicles with run-flat tyres *

When switching wheels, e.g. when switching to winter tyres, use run-flat tyres as there is no spare wheel or tyre repair kit in the vehicle.

Run-flat tyres * – see page 163.

Fitting new tyres

Fit tyres in pairs or in sets, which is even better. Ensure that tyres on one axle are

- the same size
- the same design
- the same make
- and with the same tread pattern.

Fit directional tyres such that they roll in the direction of travel. The rolling direction is indicated by a symbol (e.g. an arrow) on the sidewall.

Tyres fitted opposing the rolling direction (e.g. when a tyre is changed) should be refitted as soon as possible. This is the only way to obtain full benefit from the design properties of the tyre.

Run-flat tyres * must not be combined with conventional tyres.

Observe legal requirements when disposing of tyres.

Some brands of tyres have a beaded edge for alloy wheels to protect against damage. If wheel trim is used on steel wheels with beaded-edge tyres, the following procedure must be followed:

- Wheel trims and tyres that are approved by Vauxhall for the respective vehicle and comply with all of the relevant wheel and tyre combination requirements must be used.
- If the wheel trims and tyres used are not Vauxhall-approved, the tyres must not have a beaded edge.

Warning

Use of unsuitable tyres or wheel trims could lead to sudden pressure loss and thereby accidents.

Tyre pressure

Check tyre pressure, including the spare wheel, at least every 14 days and prior to any long journey; the tyres should be checked when cold. Don't forget to check the spare *.

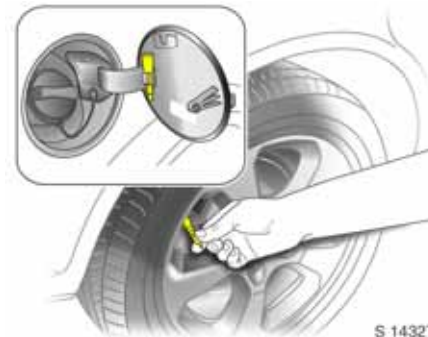

Use the valve cap key to make unscrewing the valve caps easier. The key is located on the inside of the tank flap.

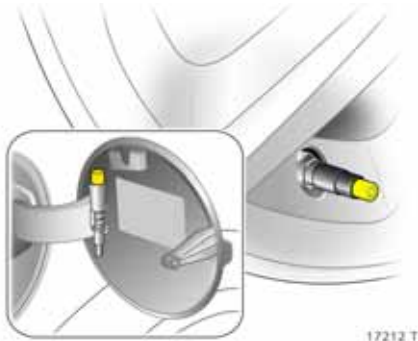

17212 T

In vehicles with Tyre Pressure Monitoring System * there is an adapter in the valve cap key. Screw adapter to valve before attaching tyre pressure gauge – see page 155.

Tyre pressure – see page 220.

Do not reduce tyre pressure when the tyres are warm. Otherwise the pressure may drop below the permissible minimum when the tyres cool down.



17213 T

After having checked the tyre pressures, tighten the valve caps using the valve cap key.

Incorrect inflation pressures will impair safety, vehicle handling, comfort and fuel economy and will increase tyre wear.

If the pressure is too low, this can result in considerable tyre warm-up and internal damage, leading to tread separation and even to tyre blow-out at high speeds.

Hidden tyre damage is not eliminated by adjusting tyre pressure.

⚠ Warning

Incorrect tyre pressure can lead to tyre rupture.

Tyre condition, wheel condition

Drive over edges slowly and at right angles if possible. Driving over sharp edges can cause concealed damage to tyres and wheels that only becomes noticeable later.

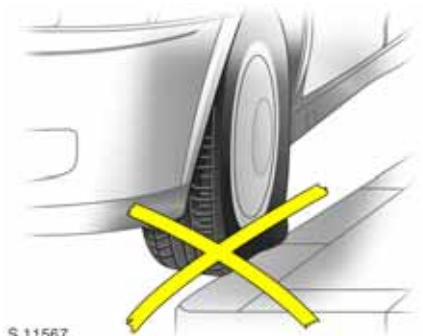

S 11567

Do not trap tyres when parking.

Check tyres regularly for damage (penetrating foreign bodies, nails, cuts, tears, bulges in side walls). Check the wheels for damage. Seek the assistance of a workshop in the event of damage or unusual wear.

⚠ Warning

Damage may lead to tyre blowout.

Tread depth

Check tread depth at regular intervals.

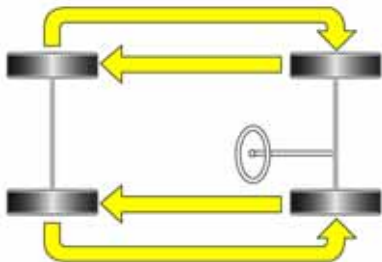

S 11568

If there is more wear at the front than the rear, swap round front wheels and rear wheels.

Correct tyre pressure. For vehicles with Deflation Detection System * or Tyre Pressure Monitoring System *, initialise the system – see pages 154, 156.



Tyres should be replaced for safety reasons if tread depth drops below 2-3 mm (4 mm for winter tyres).

The legally permissible minimum tread depth (1.6 mm) has been reached when the tread has worn down as far as one of the tread wear indicators (TWI¹⁾). A number of tread wear indicators are spaced at equal intervals around the tyre within the tread. Their position is indicated by markings on the tyre sidewall.

General information

- The danger of aquaplaning is greater if the tyres are worn.
- Tyres age, even if they are used only very little or not at all. A spare wheel which has not been used for six years should be used with care.
- Never fit used tyres the previous history and use of which you do not know.

¹⁾ **TWI** = Tread **W**ear Indicator.

- So as not to impair brake cooling, use only wheel trims approved for use on your vehicle.

Tyre designations

Meanings:

e.g. **195/65 R 15 91 H**

195 = Tyre width, mm

65 = Cross-section ratio (tyre height to tyre width), %

R = Belt type: Radial

RF = Type: RunFlat

15 = Wheel diameter, inches

91 = Load index
e.g. 91 is equivalent to 618 kg

H = Speed code letter

Speed code letters:

Q up to 100 mph (160 km/h)

S up to 112 mph (180 km/h)

T up to 118 mph (190 km/h)

H up to 130 mph (210 km/h)

V up to 150 mph (240 km/h)

W up to 168 mph (270 km/h)

Run-flat tyres (RFT) *

Run-flat tyres have reinforced, self-supporting sidewalls, which ensure that the tyres always have a certain amount of driveability, even when there is no pressure.

Run-flat tyres are only permitted on vehicles with ESP^{Plus} and Tyre Pressure Monitoring System or Deflation Detection System.

⚠ Warning
Check tyre pressures regularly even if run-flat tyres are fitted.
Check tyre pressures at least every 14 days and prior to any long journey; the tyres should be checked when cold.

Depending on tyre manufacturer, run-flat tyres can be identified from a marking on the tyre wall. E.g. **ROF** = RunonFlat for Goodyear or **SSR** = Self Supporting Runflat Tyre for Continental.

Run-flat tyres may only be used in combination with Vauxhall-approved alloy wheels; this also applies to winter tyres.

Driving with a damaged tyre

A loss in tyre pressure is indicated by the Tyre Pressure Monitoring System * or the Deflation Detection System *.

If a tyre has no pressure, continued driving is possible

- at a speed of max. 50 mph (80 km/h),
- up to a distance of 50 miles (80 km).

⚠ Warning
When driving with a flat tyre, do not exceed a speed of 50 mph (80 km/h) or a distance of 50 miles (80 km).
The vehicle will be more difficult to steer and handle and the braking distance will be longer.
Adapt driving style and speed to the conditions at hand.

Do not use a tyre repair kit.

Deflation Detection System * – see page 154, Tyre Pressure Monitoring System * – see page 155.

Winter tyres *

For notes on fitting new tyres – see page 159.

See page 220 for restrictions.

Winter tyres (M + S tyres) improve safety at temperatures below 7 °C and should therefore be fitted on all the wheels.

The design of summer tyres means they have limited qualities for winter driving.

If the maximum permissible speed for the winter tyres is less than that of the vehicle, a notice indicating the maximum permissible speed for the tyres must be affixed within the driver's field of vision¹⁾.

If you use the spare wheel when it is fitted with a summer tyre, the vehicle's driveability may be affected, especially on slippery road surfaces. Obtain a replacement for the faulty tyre as soon as possible, and have the wheel balanced and fitted to the vehicle.

Wheel trims *

If the wheel trims and tyres used are not Vauxhall-approved, make sure that the tyres do not have a beaded edge – see page 160.

Tyre chains *

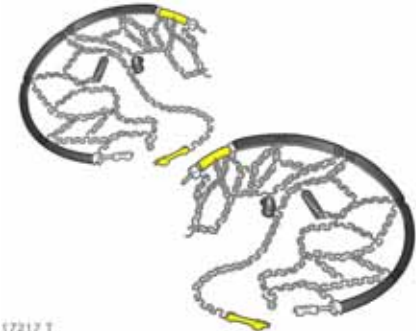

17217 T

Restrictions and further information – see page 220.

¹⁾ Varies from country to country on account of national regulations.

Tyre chains are only permitted on the drive wheels (front axle). They must be fitted to the tyres symmetrically in order to achieve a concentric fit.

Always use fine mesh chains that add no more than 10 mm to the tyre tread and the inboard sides (including chain lock).

Wheel trim on steel wheels could come into contact with parts of the chain and be damaged. Remove the wheel trim – see page 176.

Tyre chains may only be used at speeds up to 30 mph (50 km/h) and, when travelling on roads that are free of snow, they may be used for brief periods only since they are subject to rapid wear on a hard road and may snap.

Temporary spare wheel ❄

Tyre chains must not be used on the temporary spare wheel. If you need to use tyre chains after suffering a flat front tyre, fit the temporary spare on the rear axle and transfer one of the rear wheels to the front axle.

For notes on the temporary spare wheel – see page 176.

Wheel changing – see page 176.

Correct tyre pressure.

Deflation Detection System ❄ –

see page 154,

Tyre Pressure Monitoring System ❄ – see page 155.

Roof racks ❄

⚠ Warning

Disregard of these instructions may lead to injuries or endanger life. Vehicle passengers must be informed accordingly.

For safety reasons and to avoid damage to the roof, we recommend that you use the Vauxhall roof rack system approved for your vehicle.

Fasten the roof rack following the instructions that accompany the system.

Driving hints – see page 142.

Version without roof railing

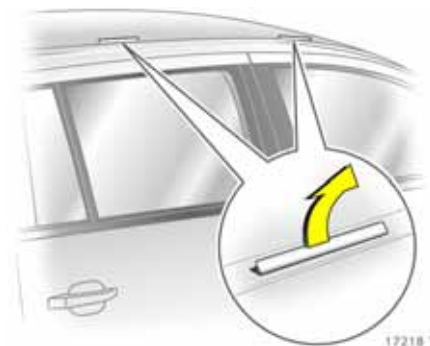

Lift the covers from the fitting openings.

Attach roof rack at appropriate points, see enclosed roof luggage rack system instructions.

Version with roof railing ❄

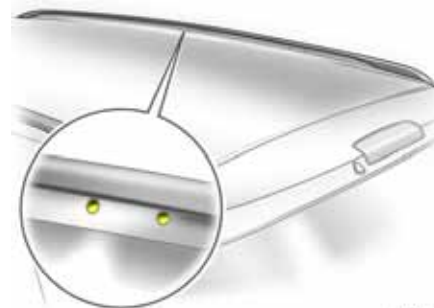

18498 T

To attach the roof rack mounting bolts in the holes shown in the diagram, see the enclosed instruction for the roof rack system.

Towing equipment ❄

⚠ Warning

Disregard of these instructions may lead to injuries or endanger life. Vehicle passengers must be informed accordingly.

Use only towing equipment that has been approved for your vehicle. We recommend entrusting the fitting of towing equipment at a later date to a workshop, whose personnel will be able to advise you on any possible towed load increases. The workshop will have instructions on how to install the towing equipment and make any

necessary changes to the vehicle that affect the cooling system, heat shields or other equipment.

⚠ Warning

When operating without a trailer, remove the coupling ball bar.

For installation dimensions of the trailer towing equipment – see page 227.

Storage of coupling ball bar



The coupling ball bar is stored in a bag, strapped into the left side of the storage compartment in the luggage compartment floor beneath a cover with a rubber strap.

Lift the carpeting to open the hatch. Raise, rotate and lift the ring.

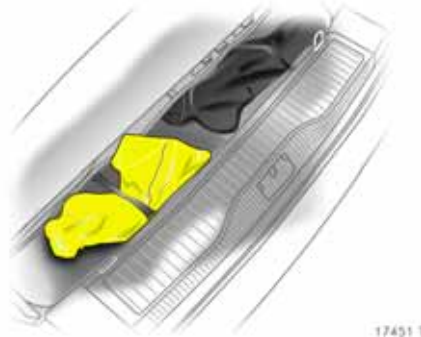

When inserting, ensure that the rotary handle of the coupling ball bar is facing upwards.

Fitting the coupling ball bar

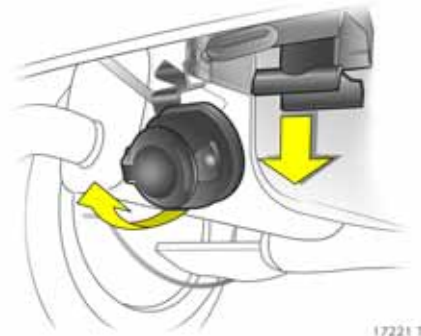

Disengage and fold down the socket. Remove the sealing plug from the hole for the coupling ball bar and stow it in the luggage compartment.

Checking the tensioning of the coupling ball bar



- Red marking on turn knob points towards white marking on coupling ball bar.
- Gap of approx. 6 millimetres between rotary knob and coupling ball bar.
- Key is in lock at position 1.

Otherwise, the coupling ball bar must be tensioned before it is inserted into the coupling housing:



- Unlock coupling ball bar (key to position 1) – see Fig. 17222 T.
- Pull turn knob out and then turn it clockwise as far as it will go – see Fig. 17223 T.

Inserting the coupling ball bar



With other versions * a cover in the bumper must be removed before inserting the coupling ball bar: pull out cover from below at recesses (at an angle, towards the rear) and store in the luggage compartment.

Insert the tensioned coupling ball bar into the coupling housing and push firmly upwards until the coupling ball bar audibly engages in position.

The turn knob snaps back into its home position resting against the coupling ball bar.

⚠ Warning

Do not touch the turn knob when inserting the coupling ball bar – risk of injury.

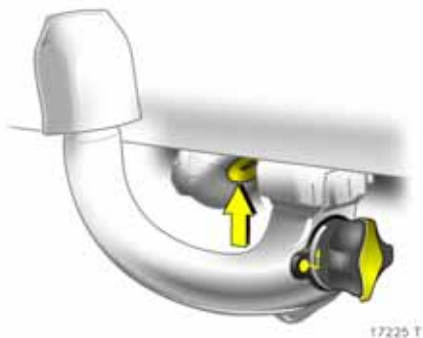

Lock coupling ball bar (key to position 2 – see page 165, Fig. 17222 T). Remove key and press protective flap into position.

When the coupling ball bar is locked the turn knob can no longer be pulled out.

Important

Check that the coupling ball bar is correctly installed:

- Green marking on turn knob points towards white marking on coupling ball bar.
- No gap between turn knob and coupling ball bar.
- Coupling ball bar must be seated firmly in coupling housing.
- Coupling ball bar must be locked and key must be removed.

⚠ Warning

Towing a caravan / trailer is permitted only when a coupling ball bar is fitted correctly. If the coupling ball bar does not engage correctly, seek the assistance of a workshop.

Eye for break-away stopping cable

In the case of caravans / trailers with brake, attach the break-away stopping cable to the eye (arrow in Fig. 17225 T).

Dismounting the coupling ball bar

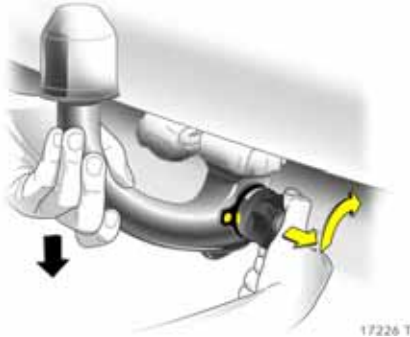

Unlock coupling ball bar (key to position 1 – see page 165, Fig. 17222 T).

Pull out turn knob and turn clockwise as far as it will go. Pull coupling ball bar down out of the coupling housing. For coupling ball bar storage – see page 165.

Insert the sealing plug in the hole for the coupling ball bar. Fold away the socket – see page 165, Fig. 17221 T.

With other versions * Replace cover in bumper: insert guides of cover into bumper, first from the front, then from the rear, and engage. Compress cover in a slightly bent position whilst doing this.

Do not use steam-jet cleaners or other high-pressure cleaners to clean the coupling ball bar.

Caravan / trailer towing Caravan and trailer loads¹⁾

The permissible caravan / trailer loads are vehicle-dependent and engine-dependent maximum values which must not be exceeded. The actual caravan / trailer load is the difference between the actual gross weight of the caravan / trailer and the actual coupling socket load with the caravan / trailer coupled. When the caravan / trailer load is being checked, therefore, only the caravan / trailer wheels – and not the jockey wheel – must be standing on the weighing apparatus.

The permissible caravan / trailer loads for your vehicle are given in the vehicle documents. Unless otherwise stated, they are valid for gradients up to max. 12%.

The permitted trailer load must only be used by drivers with adequate experience driving large or heavy trailers.

The permitted caravan / trailer load applies up to the specified incline and up to an altitude of 1000 metres above sea-level. Since engine power decreases as altitude increases because of the air becoming thinner, therefore reducing climbing ability, the permitted towing weight also decreases by 10% for every 1000 metres of additional altitude. The towing weight does not have to be reduced when driving on roads with slight inclines (less than 8%, e.g. motorways).

¹⁾ Observe national regulations.

The actual caravan / trailer load plus the actual Gross Vehicle Weight of the tow vehicle must not exceed the maximum permitted towing weight. For example, if the permitted Gross Vehicle Weight is utilised, the caravan / trailer load must only be used until the maximum permitted towing weight is reached. The maximum permitted towing weight is shown on the identification plate – see page 210.

Coupling socket load

The coupling socket load is the load exerted by the caravan / trailer on the coupling ball. It can be varied by changing the weight distribution when loading the caravan / trailer.

The maximum permissible coupling socket load (75 kg) is specified on the towing equipment identification plate and in the vehicle documents. Always aim for the maximum load, especially in the case of heavy caravans / trailers. The coupling socket load should never fall below 25 kg.

When measuring the coupling socket load, make sure that the drawbar of the loaded caravan / trailer is at the same height as it will be when the caravan / trailer is coupled with the towing vehicle loaded. Particularly important for caravans / trailers with tandem axle.

Rear axle load during towing

When the caravan / trailer is coupled and the towing vehicle fully loaded (including all occupants), the permissible rear axle load (see identification plate or vehicle documents) may be exceeded by 90 kg

and the Gross Vehicle Weight rating by 75 kg. If the permissible rear axle load is exceeded, a maximum speed of 60 mph (100 km/h) applies. If national regulations specify a lower maximum speed for vehicles towing a caravan / trailer, this must be observed.

Tyre pressure



Increase the tyre pressure on the towing vehicle to the value specified for a full load – see page 220. Check the pressure of the spare wheel and caravan / trailer wheels.

Trailer Stability Assist * (TSA)

TSA monitors vehicle movements when towing a caravan or trailer. If the system detects lurching movements, engine power is reduced and the vehicle / trailer combination is selectively braked until the lurching ceases.

TSA is a function of the Electronic Stability Programme (ESP®^{Plus}) – see page 148.

Driving characteristics, towing tips

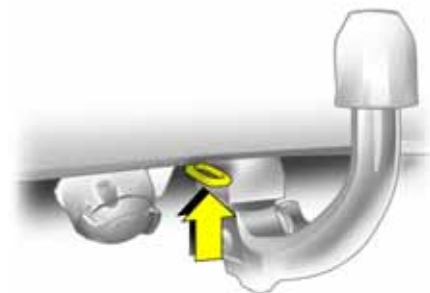

In the case of caravans / trailers with brakes, attach breakaway stopping cable to eye.

Before attaching the caravan / trailer, lubricate the ball of the caravan / trailer towing device. However, do not do so if a stabiliser, which acts on the coupling ball, is being used to damp snaking.

Check caravan / trailer lighting before starting to drive. The fog tail lights on the vehicle are deactivated when towing a caravan or trailer.

Trailers with LED turn signals must have a facility that makes light monitoring possible in a similar way to conventional filament bulbs.

Turn signal control indicators – see page 85.

Parking distance sensors * are deactivated when towing.

Handling is greatly influenced by the loading of the caravan / trailer. Loads should therefore be secured so that they cannot slip and be placed in the centre of the caravan / trailer if possible, i.e. above the axle.

For trailers with less driving stability and caravans with a permitted Gross Vehicle Weight of more than 1300 kg a speed of 50 mph (80 km/h) must not be exceeded; the use of an anti-rolling device that uses the friction principle is recommended.

Do not drive faster than 50 mph (80 km/h) if possible, even in countries where higher speeds are permitted.

Make sure that you have enough room when cornering and avoid sudden manoeuvres.

If the caravan / trailer starts to sway, drive more slowly, do not attempt to correct the steering and brake sharply if necessary.

If it is necessary to apply the brakes fully, depress the brake pedal as hard as possible.

Remember that the braking distance for vehicles towing caravans / trailers with and without brake is always greater than the braking distance for vehicles not towing a caravan / trailer.

When driving downhill, the brakes are under considerably more load when towing a caravan / trailer. For this reason, drive in the same gear as if driving uphill and drive at a similar speed.

Automatic transmission * or Easytronic * in Automatic mode will automatically select the driving programme with the optimum engine braking effect.

As necessary, gear 3, 2 or 1 can also be manually selected.

The cooling fan is electrically operated. Its cooling power is therefore independent of the engine speed.

Since a considerable amount of heat is generated at high engine speeds and less at slower speeds, do not shift down when climbing hills whilst the vehicle is still coping with the gradient in the higher gear.

Starting on inclines



For vehicles with manual transmission, the most favourable engine speed when starting-off on an incline is between 2500 and 3000 rpm for petrol engines and between 2000 and 2200 rpm for diesel engines. Hold engine speed constant, engage clutch gradually (let slip), release handbrake and open throttle. If possible, the engine speed should not drop during this procedure.

For vehicles with automatic transmission * or Easytronic * it suffices to apply full throttle in Automatic mode.

Before starting-off under extreme conditions (high combination weight, mountainous terrain with steep inclines), switch off all unnecessary electrical loads (e.g. heated rear window, air conditioning system *, heated front seats *).

Self-help, Vehicle Care

Diesel fuel system, bleeding	170
Bonnet	170
Starting	171
Starting the engine with jump leads *	171
Towing	172
Warning triangle ▲ *	
First aid kit (cushion) ⊕ *	174
Jack 🛠 * and vehicle tools.....	174
Spare wheel *.....	175
Changing wheels	176
Tyre repair kit *.....	179
Electrical system	182
Fuses and the most important circuits they protect.....	184
Bulb replacement	187
Halogen headlight system	188
Xenon headlight system *, Adaptive Forward Lighting (AFL) system *.....	191
Front fog lights *.....	192
Rear lights	192
Number plate light	193
Courtesy light	194
Vehicle care.....	195

Diesel fuel system, bleeding

Never let the tank run dry! If control indicator 🛢 illuminates, refuel as soon as possible. Refuel immediately if it flashes.

Restarting is possible after running the tank dry. Expect delayed starting. Turn over the ignition three times for 15 seconds at a time. Then start the engine for a maximum of 40 seconds. If the engine fails to start, repeat this process after no less than 5 seconds. If the engine still fails to start, seek the assistance of a workshop.

Bonnet

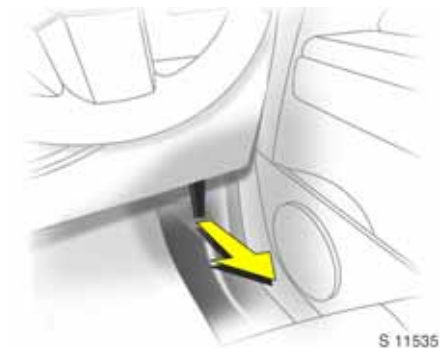

To open the bonnet, pull the release lever located on the driver's side below the instrument panel. The bonnet will then be unlocked and will open partially. Return release lever to its original position.



17381 T

There is a safety catch on the underside of the bonnet: lift this upwards and open the bonnet.

Dirt or snow on the bonnet can slide onto the windscreen when opened and block the air intake.

Air intake – see page 130.



To lock the bonnet in the open position, insert the rod lying across the radiator into the small slot on the bonnet underside. Press rod firmly into its holder before closing.

Lower the bonnet and allow it to drop into its catch.

Check that the bonnet is locked in position by pulling at its front edge. If it is not engaged, repeat the procedure.

Starting

Do not start with quick charger

This prevents damage to electronic components.

Do not start by pushing or towing

Because your vehicle is fitted with a catalytic converter, it must not be started by pushing or towing – see page 146.

Vehicle with the Open&Start system * must not be started by pushing or towing if the battery is discharged, since the steering column lock cannot be released.

The vehicle can only be started using jump leads, see following section.

Starting the engine with jump leads *

A vehicle with a discharged battery can be started using jump leads and the battery of another vehicle.

Attempts to start the vehicle should be made at intervals of one minute and should not last longer than 15 seconds

Warning

Be extremely careful when starting with jump leads. Any deviation from the following instructions can lead to injuries or damage caused by battery explosion or damage to the electrical systems of both vehicles.

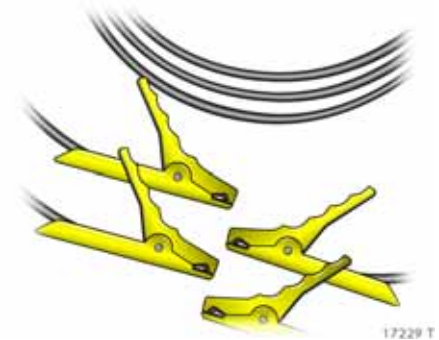

- Never expose the battery to naked flames or sparks.
- A discharged battery can freeze at temperatures of 0 °C. Defrost the frozen battery in a warm room before connecting jump leads.
- Do not allow battery fluid to come into contact with eyes, skin, fabrics or painted surfaces. The fluid contains sulphuric acid which can cause injuries and damage in the event of direct contact.
- Wear eye protection and protective clothing when handling a battery.
- Use auxiliary battery with same voltage (12 volts). Its capacity (Ah) must not be considerably less than that of the discharged battery. Voltage and capacity information can be found on the batteries.

- Use jump leads with insulated terminals and a cross section of at least 16 mm² (25 mm² for diesel engines).
- Do not disconnect the discharged battery from the vehicle.
- Switch off all unnecessary electrical consumers.
- Do not lean over the battery during jump starting.
- Do not allow the terminals of one lead to touch those of the other lead.
- The vehicles must not come into contact with each other during the jump starting process.
- Apply handbrake. Manual transmission or Easytronic * in neutral, automatic transmission * in P.

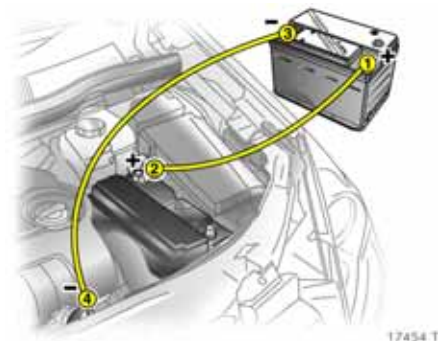

Connect the leads in the order shown in the illustration:

1. Connect one end of the first jump lead to the positive terminal 1 of the battery providing the jump start (identified by "+" sign on battery case or terminal).
 2. Connect the other end of this lead to the positive terminal 2 of the discharged battery ("+" sign).
 3. Connect the first end of the other jump lead to the negative terminal 3 of the battery providing the start ("-" sign).
 4. Connect the other end of the second jump lead 4 to ground on the other vehicle, e.g. engine block or screw connection in the engine suspension.
- Do not connect leads to negative terminal of discharged battery!
 - The connection point should be as far away from the discharged battery as possible.
 - Route the leads so that they cannot catch on rotating parts in the engine compartment.
 - Start the engine of the vehicle providing the jump.
 - After 5 minutes, start the other engine. Start attempts should be made for no longer than 15 seconds at an interval of 1 minute.
 - After the start, allow both engines to idle for 3 minutes with the leads connected.

- In order to avoid excess voltage in the electrical system, before removing a lead, switch on an electrical consumer (e.g. light, heated rear window) in the vehicle receiving the jump start.
- Reverse above sequence exactly when removing leads.

Towing Towing your own vehicle



17455 T

For fixing of the front towing eye, open front right cover strip *: disengage strip at bottom, slide to side and remove.

In another version *: Open cap covering front right towing eye socket: Release cap at bottom and remove from below.

The front towing eye is with the tool kit in a bag in a stowage compartment in the luggage compartment floor. To open the stowage compartment, lift carpet and then lift, turn and pull the tab – see page 174, Fig. 17452 T.



17456 T

Screw in the front towing eye anticlockwise as far as it will go until it stops in a horizontal position.

Attach a tow rope * – or better still a tow rod * – to the eye.

The front towing eye must only be used for towing and not recovering a vehicle.

Switch on ignition – see page 9, to release steering column lock and to permit operation of brake lights, horn and windscreen wiper.

Vehicles with the Open&Start system * must not be towed when the battery is discharged because the steering column lock cannot be released. Towing is only possible with the ignition switched on. Use jump leads to start the engine if necessary – see page 171.

Manual transmission or Easytronic * in neutral, automatic transmission * in N.

Drive slowly. Do not drive jerkily. Excessive tractive force can damage the vehicle.

⚠ Warning

For braking and steering, significantly higher forces are required: brake assistance and steering assistance are effective only with the engine running.

To prevent the entry of exhaust fumes from the towing vehicle, switch on the air recirculation * and close the windows.

Vehicles with automatic transmission * should be towed facing forwards only and must not be towed faster than 50 mph (80 km/h) or further than 60 miles (100 km). If the transmission is defective, or if the above speed or distance is to be exceeded, the front axle must be raised off the ground.

Seek the assistance of a workshop.

If the automatic clutch in vehicles with Easytronic * is released manually in the event of interruption of power supply, towing is not permitted – see page 135.

In this case, seek the immediate assistance of a workshop.

After towing, unscrew the front towing eye clockwise and refit the cover.

Towing service

Entrust your vehicle only to the towing service of your choice and obtain an estimate on towing costs before employing any towing service. In this way you avoid unnecessary costs and possible insurance problems during claim processing.

Towing another vehicle

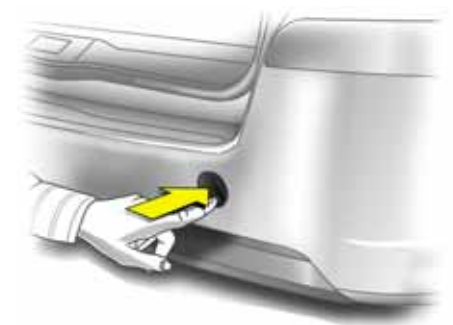

17457 T

To open the cover concealing the rear towing eye socket at the rear right of the vehicle: disengage the cover at the bottom and pull it off downwards.

The rear towing eye is with the tool kit in a bag in a stowage compartment in the luggage compartment floor. To open the stowage compartment, lift carpet and then lift, turn and pull the tab – see page 174, Fig. 17452 T.

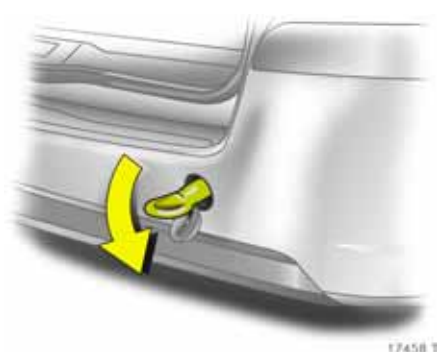

17458 T

Screw in the rear towing eye anticlockwise as far as it will go until it stops in a horizontal position.

The rigid lashing eye at the rear underneath the vehicle must never be used as a towing eye.

Attach a tow rope ❄ – or better still a tow rod ❄ – to the eye.

The rear towing eye must only be used for towing and not recovering a vehicle.

Drive slowly. Do not drive jerkily. Excessive tractive force can damage the vehicle.

After towing, unscrew the rear towing eye clockwise and refit the cover.

Warning triangle ⚠❄, First aid kit (cushion) 🛖❄



17459 T

Insert the warning triangle and the first-aid kit (cushion) in the retaining straps of the tailgate inner panelling.

Jack 🛖❄ and vehicle tools



17452 T

The jack and the vehicle tools are in a bag, strapped into a stowage compartment in the floor of the luggage compartment with a rubber strap.

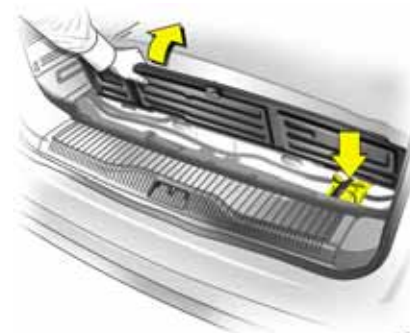

17460 T

To open the stowage compartment, lift the rear carpeting then raise, rotate and pull the ring.

To close it, insert the lugs on the front rim of the lid into the recesses and lock into place.

Spare wheel ✱



The spare wheel is kept beneath the vehicle.

Instead of a spare wheel the vehicle may be equipped with a tyre repair kit – see page 179.

- Open tool kit storage compartment in luggage compartment floor – see page 174, Fig. 17452 T.
- Fully release the hexagon bolt in the stowage compartment floor using the wheel bolt wrench.
- Lift the spare wheel holder.
- Unhook the catch and lower the spare wheel.



- Detach the safety cable.
- Lower holder all the way and remove spare wheel.
- Place replaced wheel in spare wheel holder with outside of wheel facing upwards.

Wheel changing – see page 176.



- Lift the spare wheel holder, insert the safety cable.
- Lift the spare wheel holder and engage in the catch. The open side of the catch must point in the direction of travel.

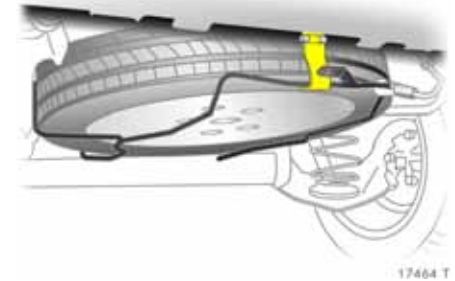

- Turn the hexagon bolt in the stowage compartment floor with the wheel bolt wrench to raise the spare wheel holder all the way up.
- Close and lock stowage compartment cover.

General information

Depending on version, the spare wheel may be in the form of a temporary spare wheel ✱. Refer to the notes in this section and on pages 164, 179, 220.

On vehicles with alloy wheels ✱, the spare wheel may have a steel rim.

If you use winter tyres ✱, the spare wheel may still be fitted with a summer tyre. If you use the spare wheel the vehicle's handling may be altered. Obtain a replacement for the faulty tyre as soon as possible, and have the wheel balanced and fitted to the vehicle.

The spare wheel may be fitted with a smaller tyre and a smaller rim than the other wheels on the vehicle: using the spare wheel may alter the handling of the vehicle. Replace a defective tyre as soon as possible, balance the wheel and have it mounted on the vehicle.

Notes on temporary spare wheel ✱

- Using a temporary spare wheel may change the driving behaviour of the vehicle, particularly if using winter tyres ✱. Replace defective tyre as quickly as possible, balance wheel and fit to vehicle.
- Fit only one temporary spare wheel.
- Do not drive faster than 50 mph (80 km/h).
- Take curves slowly.
- Do not use for a lengthy period.
- Replace temporary spare wheel with full specification wheel without delay.
- Tyre chains are not permitted on the temporary spare wheel. If tyre chains are necessary after a front wheel puncture, fit the temporary spare wheel to the rear

and a rear wheel to the front. Check tyre pressure and adjust if necessary – see page 220.

- Follow temporary spare wheel instructions on pages 164, 179 and 220.

Notes on directional tyres ✱

Tyre with a prescribed rotating direction can only achieve their maximum performance if they are fitted in the prescribed rotating direction. If a tyre or spare wheel is fitted that is rotating in the wrong direction due to a puncture, the following must be noted:

- The handling of the vehicle may be different. Replace defective tyres as soon as possible, have wheel balanced and fitted to the vehicle.
- Do not drive faster than 50 mph (80 km/h).
- Drive particularly carefully on wet and snow-covered road surfaces.
- For more information on tyres with a prescribed rotating direction – see page 163.

Changing wheels

There may be a tyre repair kit instead of a spare wheel – see page 179.

To ensure your safety, make the following preparations and observe the following information when changing wheels:

- Park the vehicle on a level, firm and non-skid surface.
- Switch on hazard warning lights, apply handbrake, for manual transmission or Easytronic ✱ - engage 1st or reverse gear, for automatic transmission ✱ - selector lever in P.
- Correctly set up the warning triangle ✱. Warning triangle – see page 174.
- Remove spare wheel – see page 175.
- Before raising the vehicle, set the front wheels to the straight-ahead position.
- Never change more than one wheel at once.
- Block wheel that is diagonally opposite to wheel being changed by placing wedges or the like in front of and behind the wheel.
- Use the jack ✱ only to change wheels.
- If the ground on which the vehicle is standing is soft, a solid board (max. 1 cm thick) should be placed under the jack ✱. Using a thicker board could damage the jack ✱ and the vehicle.
- No people or animals may be in the vehicle when it is jacked-up.
- Never crawl under a jacked-up vehicle.
- Do not start or run the engine while the vehicle is on the jack.

- Before screwing in the wheel bolts when changing a wheel, you must apply a light coating of grease to the wheel bolts. Keep a standard commercial grease with you for this reason.



1. Pull off wheel trim with hook provided in toolkit ✱. For vehicle tools – see page 174.

With wheel trims with visible wheel bolts ✱ the trim can remain on the wheel. Retaining washers ✱ on wheel bolts must not be removed.



Alloy wheels ✱: Disengage wheel bolt caps with a screwdriver and remove. To protect the wheel, place a soft cloth between the screwdriver and the alloy wheel.

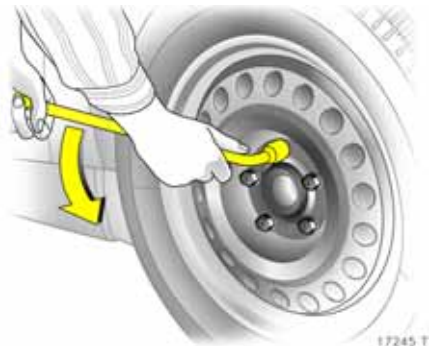

2. Turn wheel bolts half a turn using the wheel bolt wrench ✱, pushing the wrench ✱ on as far as possible.

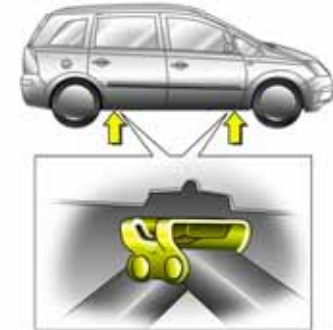

3. The location of each jacking point ✱ is indicated by a mark on the bottom edge of the vehicle.

For vehicles with side skirt trims ✱, the jack ✱ may not be used as it may damage the vehicle.

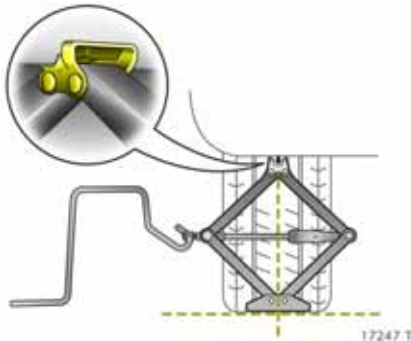

4. Before positioning the jack ✱, set it to the necessary height by rotating the eye by hand. Position the jack ✱ at the front or rear so that the jack claw spans the vertical base and grips in the recess in the vertical base. Make sure it is properly positioned.

The jack base must be on the ground directly below the jacking point in a manner that prevents it from slipping.

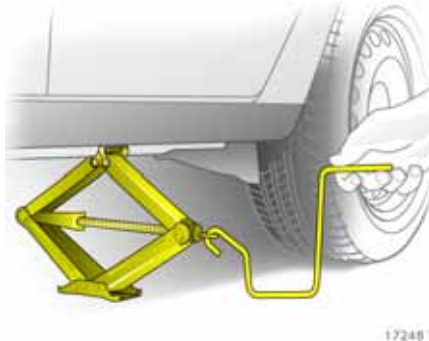

Attach crank to eye of threaded rod and turn crank to raise vehicle.

If this is not the case, carefully lower the vehicle immediately and reposition the jack.

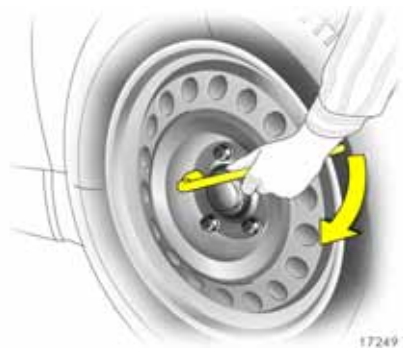

5. Unscrew wheel bolts and wipe clean with a cloth. Then apply a light coating of grease to the wheel bolts. Do not grease the thread of the bolts. Do not put the wheel bolts down in a location where they may become soiled.
If the wheel bolts have retaining washers ✱, they must not be removed.
6. Change the wheel. Notes on spare wheel – see page 175. Notes on temporary spare wheel – see page 176.
7. Screw in wheel bolts and tighten slightly, inserting the wheel bolt wrench ✱ as far as possible.
8. Lower vehicle.
9. Tighten wheel bolts crosswise, putting on wheel bolt wrench ✱ as far as possible.
10. Before refitting the wheel cover clean the wheel around the retaining clips. Valve symbol ✱ on back of wheel cover must point towards valve on wheel.
Align and refit wheel trim or wheel bolt caps ✱.
Alloy wheels ✱: Align and refit wheel bolt caps ✱.
11. Stow the removed wheel, tools and warning triangle ✱ – see pages 174, 175.
12. Check the tyre pressure of the newly fitted wheel. Adjust as necessary.

13. Have the tightening torque of the wheel bolts on the new wheel checked on the vehicle using a torque wrench as soon as possible and, if necessary, corrected. Tightening torque – see page 220.
14. Replace changed, defective tyre with a new one.
15. Replace temporary spare wheel * with a full specification wheel without delay.
16. Initialise the Deflation Detection System * or Tyre Pressure Monitoring System * – see pages 154, 155.

Tyre repair kit *

Minor damage to the tyre tread or side wall, e.g. from foreign bodies, can be repaired using the tyre repair kit (does not apply to run-flat tyres).

Do not remove foreign bodies from the tyres.

Damaged areas bigger than 4 mm and damage at the tyre rim cannot be repaired using the tyre repair kit.

Warning

Driving with low tyre pressures or depressurised tyres may lead to invisible tyre damage. This damage cannot be rectified using the tyre repair kit. Turn off your vehicle and seek the assistance of a workshop.

For important information – see page 181.

If you have a flat tyre:

- Switch on hazard warning lights, apply handbrake, automatic transmission * selector lever in park position **P**, with manual transmission or Easytronic * engage 1st gear or reverse gear.
- Correctly set up the warning triangle *. Warning triangle – see page 174.

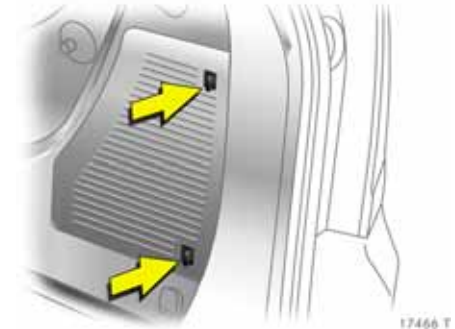

The tyre repair kit is in a stowage compartment on the right in the luggage compartment.

To open the compartment, push locking tabs forwards and remove cover.



1. Take the sealant bottle and bracket with air hose from the compartment.



2. Detach air hose from bracket and screw onto sealant bottle connection.

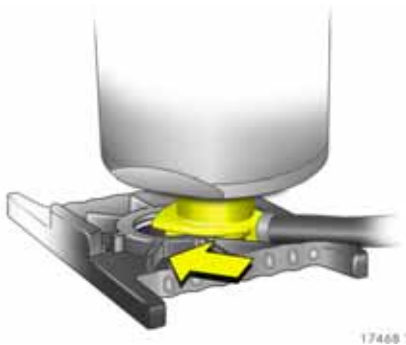

3. Position sealant bottle on bracket as illustrated above. Make sure that the bottle does not fall.



4. Unscrew dust cap from defective tyre.
5. Screw tyre inflation hose to valve.



6. Screw air hose onto compressor connection.
7. Swivel cover of electrical connection upwards from the left, see arrow in Fig. 17944 T, and disconnect plug.

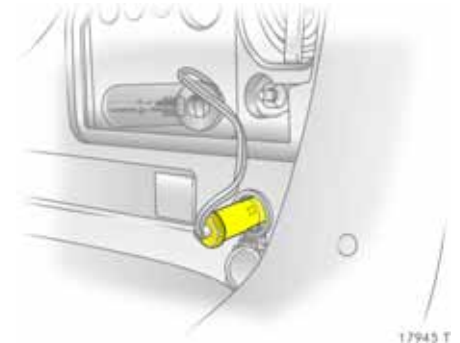

8. Swivel up the accessory socket at the right rear side of the luggage compartment and insert plug of tyre repair kit.

To avoid discharging the battery, we recommend running the engine.



9. Press button **+** on the compressor.
The tyre is filled with sealant.
10. The compressor pressure gauge briefly indicates up to 6 bar (87 psi) whilst the sealant bottle is emptying (approx. 30 seconds). Then the pressure starts to drop.
11. All of the sealant is pumped into the tyre. Then the tyre is inflated.
12. The prescribed tyre pressure – see page 220, should be obtained within 10 minutes. When the correct pressure is obtained, switch off the compressor by pressing button **+** again.

If the prescribed tyre pressure is not achieved within 10 minutes, the tyre is too heavily damaged. Turn off your vehicle and seek the assistance of a workshop.

Release excess tyre pressure using button **-**.

Do not run the compressor for more than 10 minutes, see "Important information" on page 181.
13. Disconnect plug from accessory socket, place in plug compartment and remove tyre repair kit. Push catch on bracket to remove sealant bottle from bracket. Screw tyre inflating hose to free connection of sealant bottle. This prevents sealant from escaping. Stow tyre repair kit in luggage compartment.
14. Remove any excess sealant using a cloth.
15. Collapse warning triangle ***** and stow in luggage compartment – see page 174.
16. Attach the sticker containing the maximum permitted speed that is affixed to the sealant bottle within the driver's field of view. For sticker – see page 180, Fig. 17469 T.
17. Continue driving immediately so that sealant is evenly distributed in the tyre. After driving approx. 6 miles (10 km) but no more than 10 minutes, stop and check tyre pressure. Screw compressor air hose directly onto tyre valve and compressor when doing this.

As long as the tyre pressure is more than 1.3 bar (19 psi), it may be adjusted to the prescribed value. Repeat the procedure until there is no more loss of pressure.

If the tyre pressure has fallen below 1.3 bar (19 psi), the vehicle must not be used. Seek the assistance of a workshop.
18. Stow away tyre repair kit behind cover on right in side panelling in luggage compartment. To close, insert cover at rear and engage in panelling.

Important

Warning

Do not drive faster than 50 mph (80 km/h).

Do not use for a lengthy period.

Steering and handling may be affected.

The driving characteristics of the repaired tyre is severely affected, therefore have this tyre replaced.

If unusual noise is heard or the compressor becomes hot, turn compressor off for at least 30 minutes.

The built-in safety valve opens at a pressure of 7 bar (102 psi).

Protect compressor from moisture and rain.

The sealant can only be stored for approx. 4 years, after which time its sealing capability is no longer guaranteed. Pay attention to storage information on sealant bottle.

The sealant bottle can only be used once. Replace used sealant bottle.

The compressor and sealant can be used from approx. -30 °C.

Dispose of used tyre repair kits in accordance with the applicable laws.

The adapters supplied * can be used to pump up other items e.g. footballs, air mattresses, inflatable dinghies etc.

When using the tyre repair kit, no consumers may be connected to the front accessory socket.

Electrical system



Warning

Electronic ignition systems use a very high voltage. Do not touch the ignition system; danger to life.

Fuses

The vehicle has two fuseboxes: one behind a cover on the left side of the luggage compartment and one in the front left of the engine compartment.

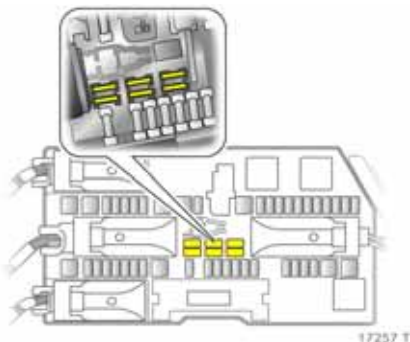

We recommend that you keep a complete set of fuses in the vehicle.

Store spare fuses in the fusebox in the luggage compartment. Open the cover – see page 184.

Before replacing a fuse, turn off the respective switch and the ignition.

A blown fuse (see the following illustrations) can be recognised by its melted wire. Do not install a new fuse until the cause of the fault has been remedied.

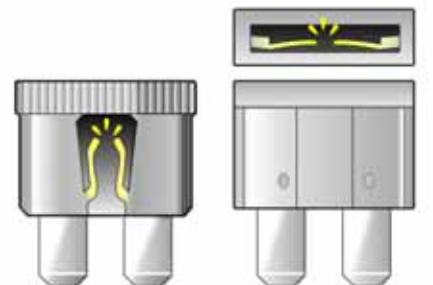

Different types of fuse are used.

Fuse colour	Fuse rating
Brownish yellow	5 A
Brown	7.5 A
Red	10 A
Blue	15 A
Yellow	20 A
Transparent	25 A
Green	30 A



17260 T

Fuse colour	Fuse rating
Blue	20 A
Transparent	25 A
Pink	30 A
Green	40 A

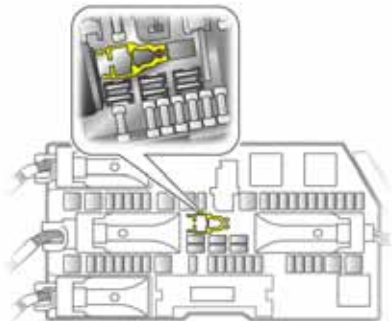

17258 T

There is a fuse extractor in the luggage compartment fusebox to facilitate replacement of fuses – see Fig. 17258 T for an example.

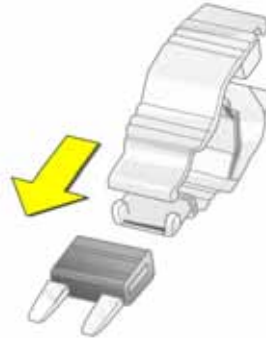

18499 T

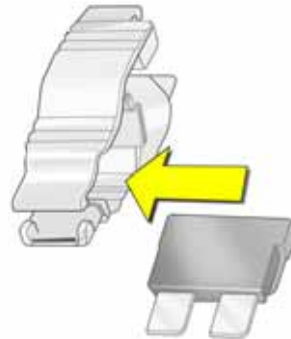

18500 T



18501 T

Place the fuse extractor on the various types of fuse from the top or side, and withdraw fuse.

Only install fuses of the specified rating. Each fuse has its rating written on it, in addition the fuses are colour coded.

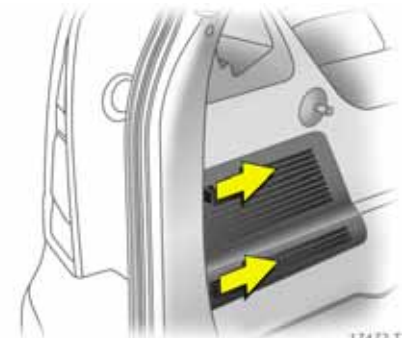

17472 T

Fuses and the most important circuits they protect

Fusebox in luggage compartment

The fusebox is on the left in the luggage compartment behind a cover. To open the compartment, push locking tabs forwards and remove cover.

Do not store any objects behind the cover.

Depending on the equipment version, there are two different fuseboxes in the luggage compartment for differing electrical circuits.

■ Version A – see Fig. 18504 T

■ Version B – see Fig. 17958 T

Spare fuses, fuse extractor – see page 182.

Fusebox version A



Some functions can be protected by several fuses. Pry off relevant cap to change the fuse.

No.	Circuit	Rating
1	Front fog lights	15 A
2	Rear socket	15 A
3	Luggage compartment socket	15 A
4	Reversing lights	7.5 A
5	Electric windows, rear	30 A
6	Air conditioning system	10 A
7	Electric windows, front	30 A
8	Heated exterior mirrors	7.5 A

Fusebox version B

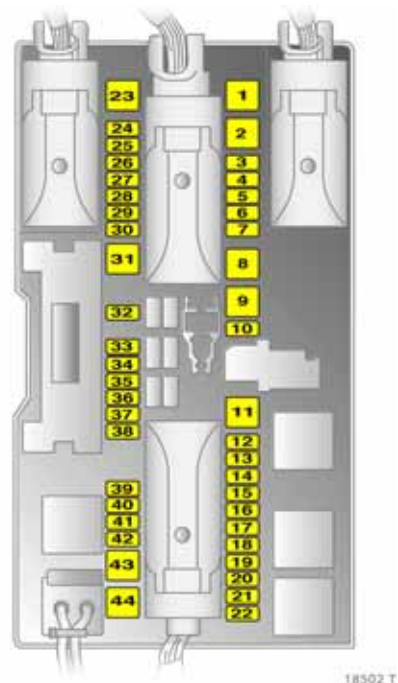

Some functions are protected by several fuses.

No.	Circuit	Rating
1	Electric windows, front	25 A
2	–	–
3	Instruments	7.5 A

No.	Circuit	Rating
4	Heating, air conditioning system, Electronic Climate Control (ECC)	5 A
5	Airbags	7.5 A
6	–	–
7	–	–
8	–	–
9	–	–
10	–	–
11	Heated rear window	25 A
12	Rear window wiper	15 A
13	Parking distance sensors	5 A
14	Heating, air conditioning system	7.5
15	–	–
16	Seat occupancy recognition, Open&Start system	5 A
17	Rain sensor, air quality sensor, Tyre Pressure Monitoring System, interior mirror	5 A
18	Instruments, switches	5 A
19	–	–
20	CDC	10 A
21	Heated exterior mirrors	7.5 A
22	–	–
23	Electric windows, rear	25 A
24	Diagnostics plug	7.5 A
25	–	–

No.	Circuit	Rating
26	Electrically retractable exterior mirrors	7.5 A
27	Ultrasonic sensor, Vauxhall alarm system	5 A
28	–	–
29	Cigarette lighter, front socket	15 A
30	Rear socket	15 A
31	–	–
32	–	–
33	Open&Start system	15 A
34	–	–
35	Rear socket	15 A
36	Towing equipment	20 A
37	–	–
38	Central locking system, terminal 30	25 A
39	Seat heater (left)	15 A
40	Seat heater (right)	15 A
41	–	–
42	–	–
43	–	–
44	–	–

Fusebox in engine compartment



The fusebox is at the front left of the engine compartment.

Warning

Turn off engine before opening engine compartment fusebox; risk of injury – see page 201.

To open the cover, release the catch by inserting a screwdriver into the opening as far as it will go and swivelling it to the side. Open the cover upwards and remove.

Depending on the equipment variant there are two different fuse assignments in the engine compartment fusebox that cover different power circuits:

- If fusebox variant **A** is in the luggage compartment – see Fig. 18504 T, page 184, the version **A** fuse assignments apply, see next page.

■ If fuse box variant **B** is in the luggage compartment – see Fig. 17958 T, page 184, the version **B** fuse assignments apply – see following page. Spare fuses, fuse extractor – see page 182.

Version A fuse assignments

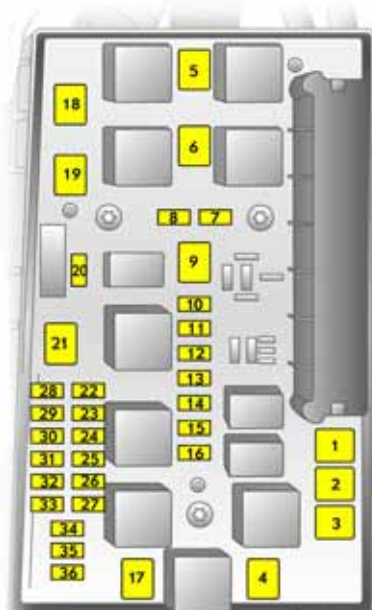

18503 T

Some functions are protected by several fuses.

No.	Circuit	Rating
1	ABS	20 A
2	ABS	30 A
3	Interior fan, Electronic Climate Control (ECC)	40 A
4	Interior fan, heating, air conditioning system	40 A
5	Cooling fan 1 (depending on engine)	30 A 40 A
6	Cooling fan 2 (depending on engine)	20 A 30 A 40 A
7	Central locking system	20 A
8	Windscreen wash system, tailgate	10 A
9	Heated rear window, heated exterior mirror	30 A
10	Diagnostics plug	7.5 A
11	Instruments	7.5 A
12	Mobile telephone, digital radio, Twin Audio, display	7.5
13	Courtesy light	5 A
14	Windscreen wiper	30 A
15	Windscreen wiper	30 A
16	Horn, ABS, brake light switch, air conditioning system	5 A
17	Diesel particle filter or air conditioning system	25 A 20 A

No.	Circuit	Rating
18	Starter	25 A
19	–	–
20	Horn	15 A
21	Engine electronics	20 A
22	Engine electronics	7.5 A
23	Headlight range adjustment	5 A
24	Fuel pump	15 A
25	–	–
26	Engine electronics	10 A
27	Heating, air conditioning system, air quality sensor	7.5 A
28	–	–
29	Electro-hydraulic power-assisted steering	5 A
30	Engine electronics	10 A
31	Rear window wiper	15 A
32	Brake light switch	5 A
33	Headlight range adjustment, light switch, clutch switch, instrument, driver's door module	5 A
34	Control unit, steering column module	7.5 A
35	Infotainment system	20 A
36	Cigarette lighter, front socket	15 A

Version B fuse assignments



18503 T

Some functions are protected by several fuses.

No.	Circuit	Rating
1	ABS	20 A
2	ABS	30 A
3	Interior fan, Electronic Climate Control (ECC)	40 A

No.	Circuit	Rating
4	Interior fan, heating, air conditioning system	40 A
5	Cooling fan 1 (depending on engine)	30 A 40 A
6	Cooling fan 2 (depending on engine)	20 A 30 A 40 A
7	Windscreen wash system	10 A
8	Horn	15 A
9	Headlight wash system	25 A
10	Emergency unlocking of central locking system	20 A
11	-	-
12	-	-
13	Front fog lights	15 A
14	Windscreen wiper	30 A
15	Windscreen wiper	30 A
16	Control module electronics, Open&Start system, ABS, brake light switch	5 A
17	Diesel particle filter heating	25 A
18	Starter	25 A
19	Transmission electronics	30 A
20	Air conditioning system	10 A
21	Engine electronics	20 A
22	Engine electronics	7.5 A
23	Adaptive Forward Lighting, headlight range adjustment	10 A
24	Fuel pump	15 A

No.	Circuit	Rating
25	Transmission electronics	15 A
26	Engine electronics	10 A
27	Electro-hydraulic power-assisted steering	5 A
28	Transmission electronics	5 A
29	Transmission electronics	7.5 A
30	Engine electronics	10 A
31	Adaptive Forward Lighting, headlight range adjustment	10 A
32	Brake system, air conditioning system, clutch switch	5 A
33	Adaptive Forward Lighting, headlight range adjustment, light switch	5 A
34	Control unit steering column module	7.5 A
35	Infotainment system	20 A
36	Mobile telephone, digital radio, Twin Audio, display	7.5 A

Bulb replacement

Before replacing a bulb, switch ignition off and switch relevant switch off.

Only hold new bulb at base! Do not touch the bulb glass with bare hands, otherwise fingerprints on the glass evaporate. Residue builds up on the reflector eventually resulting in a dull reflector. Inadvertently stained bulbs may be cleaned with a clean lint-free cloth, using alcohol or white spirit.

Replacement bulb must be in accordance with data on base of defective bulb. Do not exceed wattage given on bulb base.

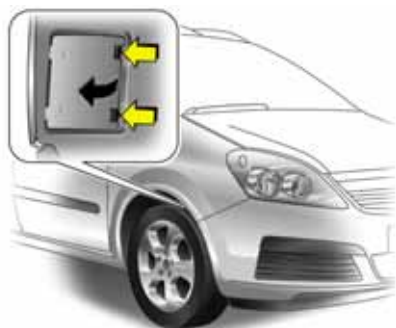

17473 T

The bulbs of the front exterior lights are replaced through openings in the front wheel arch: turn relevant wheels to gain access, release catch and remove cover.

Headlight aiming

We recommend that headlight aiming be carried out by a workshop, who will have special equipment.

When aiming your headlights, the manual headlight range adjustment * must be set to 0.

Halogen headlight system

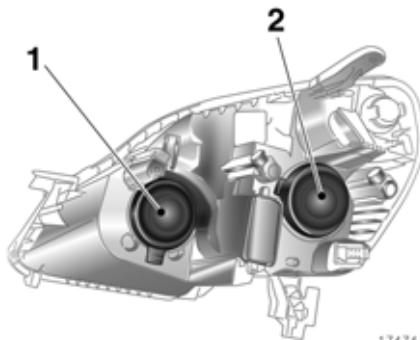

17474 T

Headlights with separate systems for main beam 1 (inner bulbs) and dipped beam 2 (outer bulbs).

Dipped beam

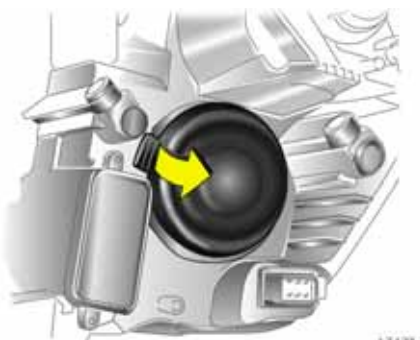

17475 T

1. Replace bulb through opening in the front wheel arch: turn relevant wheel to gain access, release catch and remove cover – see page 187.
2. Remove headlight protective cover.

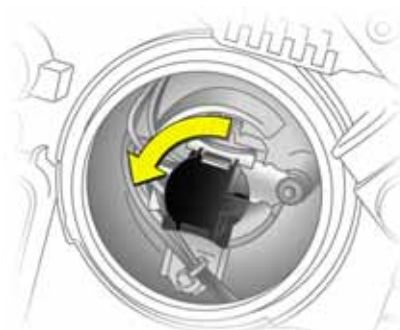

17476 T

3. Rotate left bulb carrier and disengage.



17477 T

4. Remove the bulb holder with bulb from the reflector.

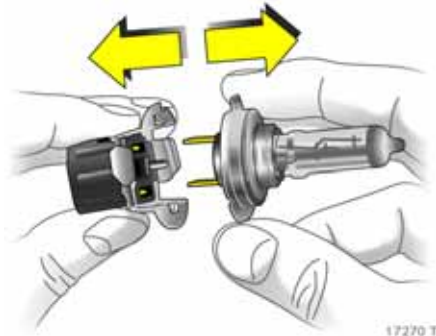

5. Detach bulb from bulb mounting.
6. Insert new bulb into bulb mounting, without touching the glass.
7. Insert new bulb so that the two lugs on the bulb mounting engage in the recesses in the reflector.
8. Rotate bulb carrier to right as far as it will go.
9. Place headlight protective cover in position and close.
10. Position cover on opening in wheel arch and engage.

Main beam



1. Open and support the bonnet.
2. Replace bulbs from engine compartment side.
To replace the bulb on the right-hand side, remove the air hose from the air filter.
To replace the bulb on the left-hand side, remove the plug from the fusebox.
3. Remove headlight protective cover.
4. Detach plug connector from bulb.



5. Disengage spring clip from retainer by pressing forwards and then swing downward.
6. Remove bulb from reflector housing.
7. When fitting a new bulb, engage the lugs in the recesses on the reflector without touching the glass.
8. Engage spring wire clip, plug connector onto bulb.
9. Place headlight protective cover in position and close.
After bulb replacement on the right-hand side, reattach air hose to air filter and engage.
After bulb replacement on the left-hand side, reconnect plug to fusebox and engage.

Parking lights

1. Open and support the bonnet.
2. Replace bulbs from engine compartment side.

To replace the bulb on the right-hand side, remove the air hose from the air filter.

To replace the bulb on the left-hand side, remove the plug from the fusebox.



3. Remove main beam headlight protective cover.

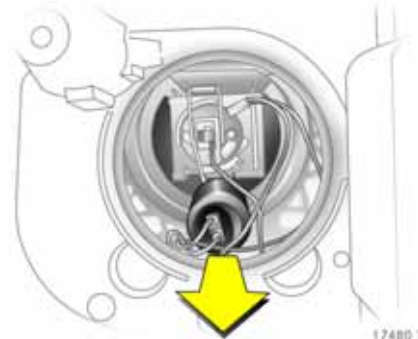

4. Remove parking light bulb holder from reflector.

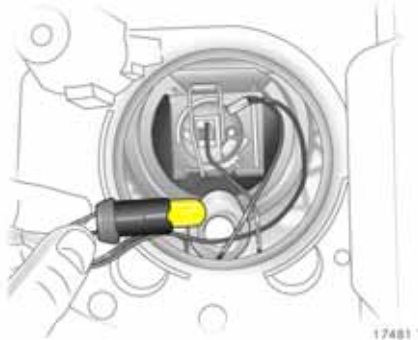

5. Remove bulb from socket.
6. Insert new bulb, without touching the glass.
7. Insert holder in reflector. Place headlight protective cap in position and close.

After bulb replacement on the right-hand side, reattach air hose to air filter and engage.

After bulb replacement on the left-hand side, reconnect plug to fusebox and engage.

Front turn signal lights

1. Open and support the bonnet.
2. Replace bulb through opening in the front wheel arch: turn relevant wheel to gain access, release catch and remove cover – see page 187.

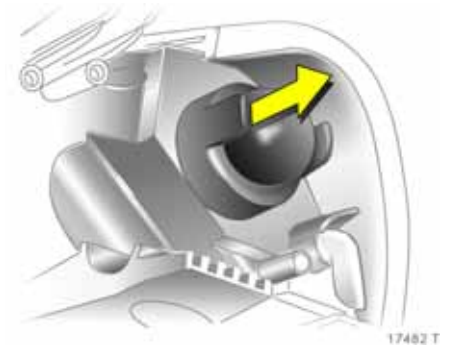

3. Remove protective cover.

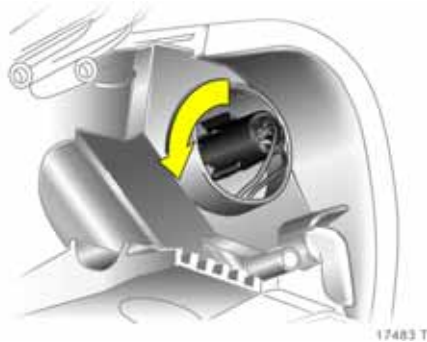

17483 T

4. Rotate bulb holder to left and disengage.
5. Push bulb into socket slightly, rotate left and remove.

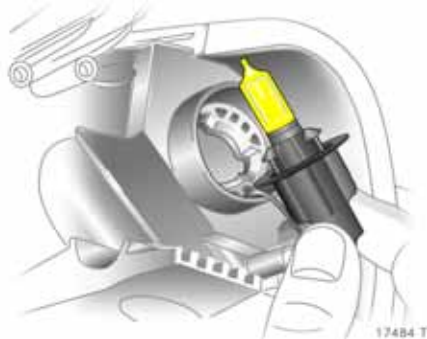

17484 T

6. Insert new bulb, without touching the glass.

7. Insert light holder in reflector, rotate clockwise and engage in position.
8. Position cover on opening in wheel arch and engage.

Xenon headlight system *, Adaptive Forward Lighting (AFL) system *

Xenon headlight system in conjunction with adjustable lighting depending on steering deflection.

Warning

Xenon headlights operate at very high voltages. Do not touch, risk of fatal injury. Have dipped beam, main beam, side lights and parking lights replaced by a workshop only.

Front turn signal lights

1. Open and support the bonnet.
2. Replace bulbs from engine compartment side.

To replace the bulb on the right-hand side, remove the air hose from the air filter.

To replace the bulb on the left-hand side, remove the plug from the fusebox.



17485 T

3. Rotate bulb holder to left and disengage.

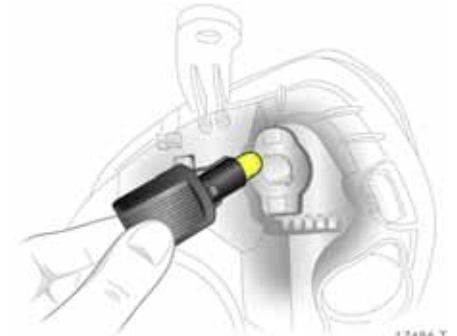

17486 T

4. Push bulb into socket slightly, rotate left and remove.
5. Insert new bulb, without touching the glass.

6. Insert light holder in reflector, rotate clockwise and engage in position.

After bulb replacement on the right-hand side, reattach air hose to air filter and engage.

After bulb replacement on the left-hand side, reconnect plug to fusebox and engage.

Front fog lights *

Have lights replaced by a workshop.

Rear lights

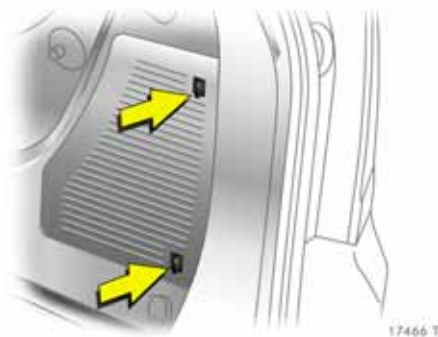

1. To change the bulbs on the right side, open the side cover. Push locking tabs forwards and remove cover.

Remove foam container and tyre repair kit *.

To change the bulbs on the left side, take off the luggage compartment bracket and cover and open the side cover: Push locking tabs forwards and remove cover.

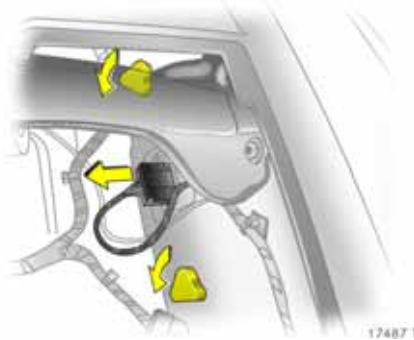

2. Compress plug connector and pull from bulb carrier.

3. Unscrew two plastic securing nuts from the inside by hand.

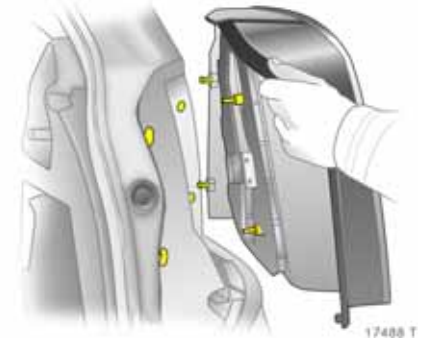

4. Pull bulb housing backwards.

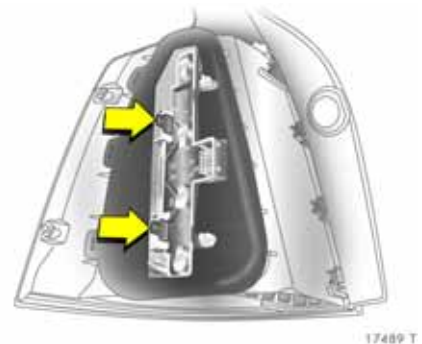

5. Disengage both locking tabs from the bulb carrier and remove bulb carrier.

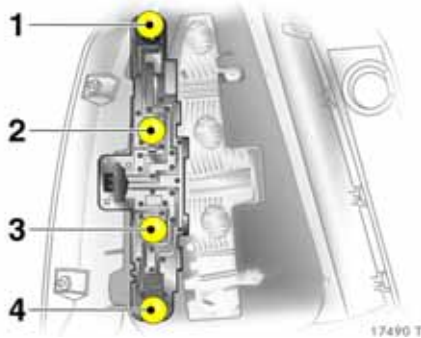

Bulbs in bulb holder:

- 1 = Tail light / brake light
- 2 = Turn signal light
- 3 = Fog tail light
- 4 = Reversing light

6. Remove bulb from socket.

Insert new bulb without touching the glass. Engage bulb holder in bulb housing. Engage plug connector. Insert bulb housing in vehicle body and tighten attachment nuts by hand. On the right-hand side, insert foam container and tyre repair kit *. Engage cover flap in luggage compartment. Engage luggage compartment bracket.

7. Check that rear lights are operating correctly after bulb replacement:

- Switch on ignition
- Operate brake
- Switch on parking lights

Number plate light

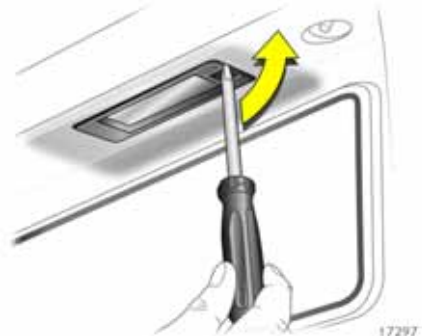

1. Insert screwdriver vertically in bulb insert as shown in illustration. Press to the side and release spring.

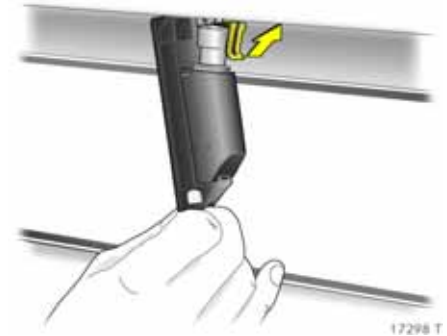

2. Remove bulb housing downward, taking care not to pull on the cable.
 3. Lift flap and disconnect plug from bulb socket.



4. Rotate bulb socket anticlockwise and disengage.
 5. Remove bulb from socket.

6. Insert new bulb, without touching the glass.
7. Insert bulb holder in bulb housing and turn to the right.
8. Connect plug to bulb socket.
9. Insert and engage bulb housing.

Courtesy light

Front courtesy light, reading lights*

To ensure that no power is supplied to the lights, close the doors before removing.

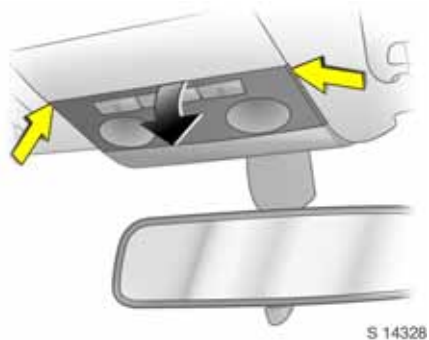

1. Disengage lens by hand at location shown in illustration, press it downward slightly and remove at a downward angle.
2. Remove bulb from socket.
3. Insert new bulb, without touching the glass.
4. Mount lens and engage in position.

Courtesy lights and reading lights above second and third rows of seats

Have lights replaced by a workshop.

Glove compartment lighting, luggage compartment lighting, footwell lighting*

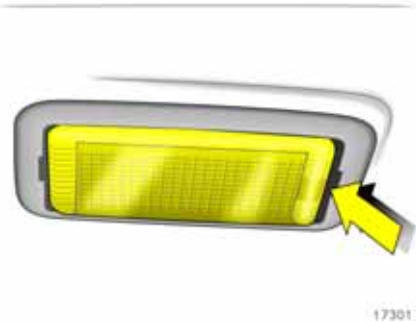

Close doors or hold down contact switch before removing lights so that they are not live.

1. Prise the light out with a screwdriver.



2. Press bulb slightly towards spring clip and remove.
3. Insert new bulb, without touching the glass.
4. Insert light in opening and engage in position.

Instrument illumination, Information display illumination*

Have lights replaced by a workshop.

Vehicle care

When caring for your vehicle, observe all national environmental regulations, particularly when washing it.

Regular, thorough care helps to improve the appearance of your vehicle and maintain its value over the years. It is also a prerequisite for warranty claims for any paint or corrosion damage. The following pages contain tips for vehicle care which, if used properly, will help combat the unavoidable damaging effects of the environment.

Vehicle care aids ✱

Vehicle wash:

- Wash brush,
- Car Shampoo,
- Car Sponges,
- Insect Removal Sponge,
- Wheel Cleaners,
- Engine Cleaners,
- Glass Cleaners,
- Chamois Leather.

Vehicle care:

- Paintwork Cleaner,
- Paintwork Polish,
- Cream Polish,
- Metallic Paintwork Wax,
- Hard wax,
- Touch-up stick,
- Touch-Up / Aerosol Paint,
- Wheel Preserver,
- Insect Remover,
- Alloy Wheel Cleaner,
- Alloy Wheel Preserver,
- Rust Preventative,
- Vauxhall De-icer Spray,
- Window Cleaning Spray,
- Vauxhall Windscreen Wash Solvent,
- Silicone Oil for Rubber Seals,
- Cleaner.

Washing

The paintwork of your vehicle is exposed to environmental influences, e.g. continuous changes in weather conditions, industrial waste gases and dust or thawing salts, so wash and wax your vehicle regularly. When using automatic car washes, select a programme which includes waxing.

Bird droppings, dead insects, resin, pollen and the like should be cleaned off immediately, as they contain aggressive constituents which can cause paint damage.

If using an automatic car wash, comply with the pertinent instructions of the car wash manufacturer. The windscreen wiper and rear window wiper must be switched off – see pages 11, 12. Remove antenna ✱ and roof rack ✱. Stand on the door sill to reach them more easily.

If you wash your vehicle by hand, make sure that the insides of the wings are also thoroughly rinsed out.

Clean edges and folds on opened doors and flaps as well as the areas they cover.

Thoroughly rinse off and leather-off the vehicle. Rinse leather frequently. Use separate leathers for paint and window surfaces: remnants of wax on the windows will impair vision.

Observe national regulations.

Waxing

Wax your vehicle regularly, in particular after it has been washed using shampoo and at the latest when water no longer forms beads on the paintwork, otherwise the paintwork will dry out.

Also wax edges and folds on opened doors and flaps as well as the areas they cover.

Polishing

Polishing is necessary only if the paint has become dull or if solid deposits have become attached to it.

Paintwork polish with silicone forms a protective film, making waxing unnecessary.

Plastic body parts such as the roof module of the panoramic roof must not be treated with preservation and polishing agents.

Use Metallic Paintwork Wax on vehicles with a metallic-effect paint finish.

Panoramic roof*

Never clean with solvents or abrasive agents, fuels, aggressive media (e.g. paint cleaner, acetone-containing solutions etc.), acidic or highly alkaline media or abrasive pads.

No stickers may be applied to the panoramic roof, and do not use plastic protector sleeves.

Wheels

Use a pH-neutral wheel cleaning agent to clean the wheels.

Wheels are painted and can be treated with the same agents as the body. For alloy wheels we recommend use of Alloy Wheel Preserver.

Paintwork damage

Immediately rectify minor paintwork damage such as stone chips, scratches, etc. using a touch-up stick or Touch-Up / Aerosol Paint before rust has a chance to form. If rust has already formed, have the cause rectified by a workshop. Note also the surfaces and edges facing the road on which rust may develop for a long period of time without being noticed.

Exterior lights

Headlight and other protective light covers are made of plastic. If they require additional cleaning after the vehicle has been washed, clean them with Car Shampoo. Do not use any abrasive or caustic agents, do not use an ice scraper, and do not clean them dry.

Plastic and rubber parts

For additional cleaning of plastic and rubber parts use Cleaner. Do not use any other agent, and in particular do not use solvents or petrol.

Do not use high-pressure jet cleaners on plastic and rubber parts.

Wheels and tyres

Do not use high-pressure jet cleaners on wheels and tyres.

Interior and upholstery

Clean the vehicle interior, including the instrument panel fascia, using interior cleaner.

The instrument panel should only be cleaned using a soft damp cloth.

Clean fabric upholstery with a vacuum cleaner and brush. To remove stains, use cleaner that is suitable for both fabrics and vinyl.

Do not use cleaning agents such as acetone, tetrachloride, paint thinner, paint remover, nail varnish remover, washing powder or bleach. Petrol is also unsuitable. Open velcro fasteners on clothing could damage seat upholstery. Make sure that velcro fasteners are closed.

Seat belts

Always keep seat belts clean and dry.

Clean only with lukewarm water or Cleaner.

Windows

When cleaning the heated rear window, make sure that the heating element on the inside of the window is not damaged.

Use a soft lint-free cloth or chamois leather in conjunction with Window Cleaner and Insect Remover.

Vauxhall Windscreen Wash Solvent is suitable for de-icing windows.

For mechanical removal of ice, use a commercially available sharp-edged ice scraper. Press the scraper firmly against the glass so that no dirt can get under it and scratch the glass.

Windscreen wiper blades

Wax such as the wax used in car washes can cause smearing on the windscreen when the windscreen wiper is switched on.

Smearing wiper blades can be cleaned with a soft cloth and Vauxhall Windscreen Wash Solvent, and replaced if necessary – see page 206.

Locks

The locks are lubricated at the factory using a high quality lock cylinder grease. Use de-icing agent only where absolutely necessary, as this removes grease and impairs lock function. After using de-icing agent, have the locks regreased by a workshop.

Engine compartment

Areas of the engine compartment that are painted in the same colour as the vehicle must be looked after like any other painted surface.

It is advisable to wash the engine compartment before and after winter and preserve it with wax. Cover alternator and brake fluid reservoir with plastic sheets before washing the engine.

When washing the engine with a steam-jet cleaner, do not direct the steam jet at components of the Anti-lock Brake System (ABS), air conditioning system, Electronic Climate Control (ECC) or the belt drive and its components.

When washing down the engine, protective wax applied afterwards is also removed. Therefore, after washing, have the engine, parts of the brake system in the engine compartment, axle components and steering and vehicle body parts and cavities preserved thoroughly by a workshop using protective wax.

An engine wash can be performed in the spring in order to remove dirt that has adhered to the engine compartment, which may also have a high salt content. Check protective wax layer and make good if necessary.

Do not use high-pressure jet cleaners in the engine compartment.

Underbody

Your vehicle has a factory-applied PVC undercoating in the wheel arches (including the longitudinal members) which provides permanent protection and needs no special maintenance. The surfaces of the vehicle underbody not covered by PVC are provided with a durable protective wax coating in critical areas.

On vehicles which are washed frequently in automatic car washes with underbody washing facility, the protective wax coating may be impaired by dirt-dissolving additives.

Therefore, check the underbody after washing and have it waxed if necessary. Before the start of the cold weather season, check the PVC coating and protective wax coating. Have them restored to perfect condition if necessary.

Caution - commercially available bitumen / rubber materials can damage the PVC coating. We recommend that you have underbody work carried out by a workshop. They know the prescribed materials and have experience in the use thereof.

The underbody should be washed following the end of the cold weather season to remove any dirt adhering to the underbody since this may also contain salt. Check protective wax coating and, if necessary, have it restored to perfect condition.

Service, Maintenance

Inspection system	200
Genuine Vauxhall Parts and Accessories	201
A note on safety	201
Checking and topping up fluids	202
Engine oil	202
Diesel fuel filter	203
Coolant	204
Brake fluid	205
Windscreen wiper	206
Windscreen and headlight wash systems *.....	207
Battery	207
Protection for electronic components	208
Vehicle decommissioning.....	209
Vehicle recommissioning.....	209

In our experience, the most common cause of all complaints is the result of misunderstanding or lack of communication between the customer and the Vauxhall Authorised Repairer.

We sincerely hope you will never have cause to complain about your vehicle. However, if things do go wrong, the best course of action for you to take is to contact your Vauxhall Authorised Repairer's Service Reception Staff and explain the difficulty you are having. We are confident they will do their utmost to resolve the problem to your complete satisfaction.

Sometimes, however, despite the best of intentions of all concerned, misunderstandings can occur. If your problem has not been resolved to your satisfaction, please make an appointment to discuss the matter with the Manager of the department concerned.

The majority of areas of concern can be quickly resolved in this way.

Should you wish to pursue the matter further, the Principal of the Vauxhall Authorised Repairer should be made aware of your concern. It is advisable in cases such as this to write to him to confirm your problem and the solutions that have been offered.

You can be assured the Authorised Repairer's Principal will only be too anxious to fully investigate your problems and correct any errors made. After all, he has a

large investment in his business and is proud of his reputation and professionalism and fully realises that satisfied customers are his key to success.

In the unlikely event that you are still not happy with the answer your Vauxhall Authorised Repairer has given, or the action he proposes to correct the problem, you may contact the Customer Care Department¹⁾ where a team of Customer Care Consultants will spare no effort to ensure your complete satisfaction.

Vauxhall Motors Ltd.

Customer Care,
Griffin House,
Osborne Road,
LUTON,
Beds., LU1 3YT
Telephone: 0845 090 2044

They will review all the facts involved. Then if it is felt some further action can be taken, the Vauxhall Authorised Repairer will be advised accordingly. In any case, your contact will be acknowledged confirming Vauxhall Motors' position in the matter.

If you are not satisfied with the outcome, you can if you wish, seek advice from an independent third party such as:

Automobile Association (A.A.)

Fanum House,
BASINGSTOKE,
Hants., RG21 2EA

¹⁾ Calls may be monitored and recorded for training purposes.

Royal Automobile Club (R.A.C.),
R.A.C. Motoring Services Ltd.,
89-91 Pall Mall,
LONDON, SW1Y 5AS

The Customer Relations Department,
Society of Motor Manufacturers and Traders Ltd. (S.M.M.T.),
Forbes House, Halkin Street,
LONDON, SW1X 7DS

Customer Complaints Service,
Scottish Motor Trade Association,
(S.M.T.A.),
3 Palmerston Place,
EDINBURGH, EH12 5AQ

The National Conciliation Service,
Retail Motor Industry Federation,
9 North Street,
RUGBY, CV21 2AB

If you have a problem whilst abroad:
The Service Departments of ADAM OPEL GmbH and General Motors branches everywhere will provide information and assistance:

In **Luxembourg** please contact the General Motors Service Department in Antwerp – Belgium
Telephone 00 32-34 50 63 29

General Motors Austria GmbH
Groß-Enzersdorfer Str. 59
1220 Vienna – Austria
Tel. 00 43 1-288 77 444 or
00 43-1-2 88 77 0

General Motors Belgium N.V.
Noorderlaan 401 – Haven 500
2030 Antwerp – Belgium
Telephone 00 32-34 50 63 29

General Motors Southeast Europe,
org. složka
Olbrachtova 9
140 00 Prague – Czech Republic
Tel. 00 420-2 39 004 321

General Motors Denmark
Jaegersborg Alle 4
2920 Charlottenlund – Denmark
Telephone 00 45-39 97 85 00

Vauxhall Motors Ltd.
Customer Care
Griffin House, Osborne Road
Luton, Bedfordshire, LU1 3YT – England
Tel. 00 44-845 090 2044

General Motors Finland Oy
Pajuniityntie 5
00320 Helsinki – Finland
Tel. 00 358-9 817 101 47

General Motors France
1 – 9, avenue du Marais
Angle Quai de Bezons
95101 Argenteuil Cedex – France
Tel. 00 33-1-34 26 30 51

ADAM OPEL GmbH
Bahnhofspatz 1
65423 Rüsselsheim – Germany
Tel. 00 49-61 42-77 50 00 or
00 49-61 42-7 70

General Motors Hellas S.A.
56 Kifisias Avenue & Delfon str.
Amarousion
151 25 Athens – Greece
Tel 00 30-1-6 80 65 01

General Motors Southeast Europe Ltd.
Szabadsag utca 117
2040 Budaörs – Hungary
Tel. 00 36-23 446 100

General Motors India
Sixth Floor, Tower A, Global Business Park
Mehrauli – Gurgaon Road
Gurgaon – 122 022, Haryana – India
Tel. 00 91-124 280 3333

General Motors Ireland Ltd.
Opel House, Unit 60, Heather Road
Sandyford, Dublin 18 – Ireland
Tel. 00 353-1-216 10 00

General Motors Italia Srl
Piazza dell'Industria 40
00144 Rome – Italy
Tel. 00 39-06-5 46 51

General Motors Nederland B.V.
Lage Mosten 49 – 63
4822 NK Breda – Netherlands
Tel. 00 31-76-5 44 83 00

General Motors Norge AS
Kjeller-Vest 6
2027 Kjeller – Norway
Tel. 00 47-23 50 01 04

General Motors Poland Sp. z o. o.
Domaniewska 41
06-672 Warsaw – Poland
Tel. 00 48- 22-606 17 00

General Motors Portugal
Quinta da Fonte
Edifício Femão Magalhães, Piso 2
2780-190 Paço d'Arcos – Portugal
Tel. 00 351- 21 440 75 00

General Motors Southeast Europe,
org. zložka
Apollo Business Centre
Mlynské Nivy 45
821 09 Bratislava – Slovakia
Tel. 00 421-2 58 275 543

General Motors España S.L.
Paseo de la Castellana, 91
28046 Madrid – Spain
Tel. 00 34-902 25 00 25

General Motors Norden AB
Årstaängvägen 17
100 73 Stockholm – Sweden
Tel. 00 46-20 333 000

General Motors Suisse S.A.
Stelzenstraße 4
8152 Glattbrugg – Switzerland
Tel. 00 41-44 828 28 80

General Motors Türkiye Ltd. Sti.
Kemalpaşa yolu üzeri
35861 Torbalı/Izmir – Turkey
Tel. 00 90-2 32-8 53-14 53

In **Albania, Bosnia-Herzegovina, Bulgaria, Croatia, Estonia, Latvia, Lithuania, Macedonia, Romania, Serbia-Montenegro and Slovenia** please contact the General Motors Service Department in Budaörs – Hungary
Tel. 00 36-23 446 100

Inspection system



In order to ensure economical and safe vehicle operation and to maintain the value of your vehicle, it is of vital importance that all maintenance work is carried out at the proper intervals as specified.

In the case of vehicles with fixed engine oil change and service intervals, **InSP** appears in the odometer display if the ignition is switched on when servicing is overdue: have the next Service carried out by a workshop within one week or 300 miles (500 km).

The service interval display takes account of off-the-road periods during which the battery is disconnected.

For vehicles with flexible engine oil change and service intervals, the length of these intervals is based on several parameters stemming from usage. For this reason, various engine-specific data is continually gathered and is used to calculate the remaining distance until the next Service.

This remaining distance can be displayed with the ignition off: briefly press the trip odometer reset button, the mileage / kilometre reading appears. Press the button again for around 2 seconds, **InSP** and the remaining distance is shown.

If the remaining distance is less than 1000 miles (1500 km), **InSP** is displayed with a remaining distance of 600 miles (1000 km) when the ignition is switched on and off. **InSP** is displayed for several seconds if the remaining distance is less than 600 miles (1000 km). Have the Service work that is due carried out within one week or 300 miles (500 km). Have this work carried out by a Vauxhall Authorised Repairer in order to avoid invalidation of warranty claims.

Further information on maintenance and the Service Plan can be found in the Service Booklet, which is in the glove compartment.

Have maintenance work and repair work on the vehicle body and engine carried out by a repairer in accordance with Vauxhall Motors' recommendations, using Genuine Vauxhall Parts and Accessories.

We recommend consulting your Vauxhall Authorised Repairer, who has excellent knowledge of Vauxhall vehicles and possesses the necessary special tools and the current Service Instructions from Vauxhall. To avoid a loss of warranty claims, you are advised to consult a Vauxhall Authorised Repairer during the warranty period in particular. For further information, see the Service Booklet.

Separate anti-corrosion service

Have this work done in accordance with the intervals specified in the Service Booklet.

Genuine Vauxhall Parts and Accessories

We recommend that you use "Genuine Vauxhall Parts and Accessories" and conversion parts approved expressly for your vehicle type. These parts have undergone special tests to establish their reliability, safety and specific suitability for Vauxhall vehicles. Despite continuous market monitoring, we cannot assess or guarantee these attributes for other products, even if they have been granted approval by the relevant authorities or in some other form.

"Genuine Vauxhall Parts and Accessories" and conversion parts approved by Vauxhall can be obtained from your Vauxhall Authorised Repairer, who can provide comprehensive advice about permitted technical changes and ensure that the part is installed correctly.

A note on safety

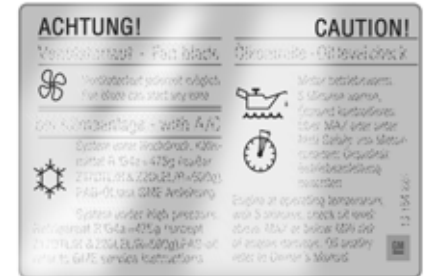

17304 T

To avoid injury from moving parts and cables conducting ignition voltage, only carry out engine compartment checks (e.g. checking brake fluid or engine oil level) when the ignition is switched off.

Warning

The cooling fan is controlled by a thermostatic switch and can therefore start unexpectedly even if the ignition is switched off. Risk of injury.

Electronic ignition systems use a very high voltage. Do not touch the ignition system; danger to life.

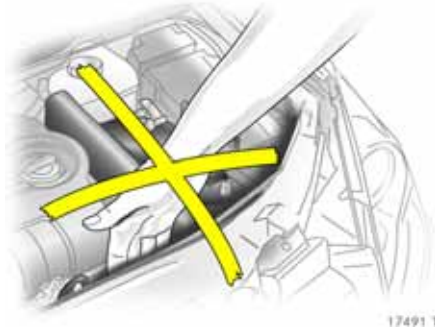

17491 T

Never carry out any repairs or adjustment and maintenance work on the vehicle yourself. This especially applies to the engine, chassis and safety parts. You may, out of ignorance, infringe the provisions of the law and, by not performing the work properly, you may endanger yourself and other road users.

Checking and topping up fluids

The caps for topping up the engine oil, the coolant, the wash fluid and the oil dipstick are yellow for ease of identification.

Engine oil

Information on engine oils is available in the Service Booklet.

Engine oil level and consumption

Every engine consumes engine oil for technical reasons. The engine oil consumption cannot be assessed until a fairly long distance has been driven, and may be above the specified value when the vehicle is first being driven (run-in period). Frequent driving at high revs increases engine oil consumption.

The engine oil level is checked automatically¹⁾ – see page 85. Before embarking on a long journey it is advisable to check the engine oil level.

Warning

Important: It is the owner's responsibility to maintain the correct level of an appropriate quality oil in the engine.

Engine oil level check, topping up engine oil



17492 T

The illustrations show checking of a petrol engine and a diesel engine.

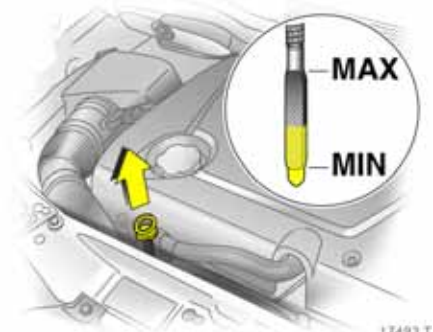

17493 T

¹⁾ Not for Z 20 LEH engine.
Sales designation – see page 212.

The oil level must be checked with the vehicle on a level surface and with the engine (which must be at operating temperature) switched off. Wait at least 5 minutes before checking the level to allow the normal engine oil accumulation in the engine to flow into the oil pan.

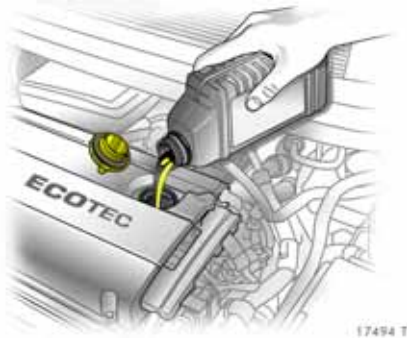

To check the engine oil level, insert wiped oil dipstick into dipstick tube as far as it will go. Top engine oil up if the level has dropped into the range of the top-up mark **MIN**.

The engine oil level must not exceed the upper mark **MAX** on the dipstick. Excess engine oil must be drained off or extracted. If the engine oil level is above the **MAX** mark, there is a risk of damage to the engine or the catalytic converter.

Capacity between **MIN** and **MAX** marks – see pages 224, 225.

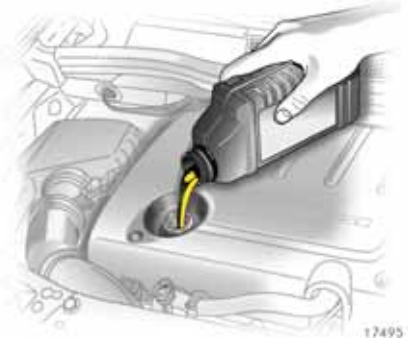

Top up with the same brand of engine oil that was used during the previous oil change, following the instructions in the Service Booklet.

To close, position the cap and screw it into place.

Capacities – see pages 224, 225.

Warning

Do not allow the engine oil to drop below the minimum level!

Engine oil change, engine oil filter change

Have engine oil and filter changed by a workshop in accordance with the service intervals indicated.



We recommend that you use genuine engine oil filters.

Warning

Empty engine oil containers are not domestic refuse. Observe legal requirements regarding protection of your health and the environment when disposing of used oil and engine oil filters.

Diesel fuel filter

When changing the engine oil, have the diesel fuel filter checked by a workshop for any residual water.

Illumination of control indicator  indicates water in the diesel fuel filter .

Have diesel fuel filter checked at shorter intervals if the vehicle is subjected to extreme operating conditions such as high humidity (primarily in coastal areas), extremely high or low outside temperatures and substantially varying daytime and night-time temperatures.

Coolant

The glycol-based coolant provides excellent corrosion protection for the heating and cooling systems as well as anti-freeze protection down to approx. -28 °C. It remains in the cooling system throughout the year and need not be changed.

Use of certain anti-freezes can lead to engine damage. We therefore recommend that you use only approved anti-freezes.

Warning

Anti-freeze is a danger to health; it must therefore be kept in the original container and out of the reach of children.

Anti-freeze and corrosion protection

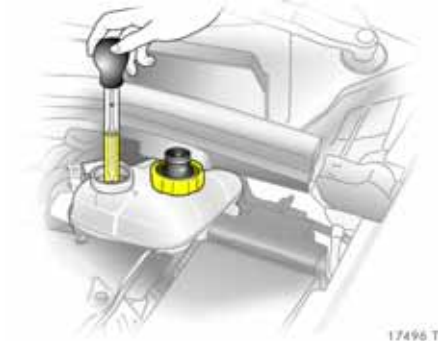

Have your coolant replaced at the correct concentration by a workshop at the start of the winter.

The frost protection must ensure anti-freeze protection down to approx. -28 °C. Too low a concentration of anti-freeze will reduce frost protection and corrosion protection. If required, top up anti-freeze.

If coolant loss is topped up with water, have concentration checked and add anti-freeze if necessary.

Coolant level

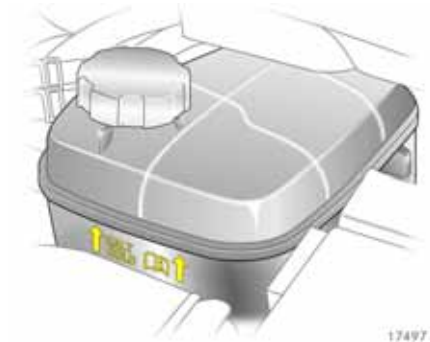

Hardly any losses occur since the cooling system is sealed and it is thus rarely necessary to top up the coolant.

The coolant should be a little above the **KALT / COLD** mark in the expansion tank with a cold cooling system. The coolant level can also be read off from the outside of the expansion tank.

Warning

Allow engine to cool down before removing coolant filler cap. Remove filler cap carefully so that pressure can escape slowly, otherwise there is a risk of scalding.

When the engine is at operating temperature, coolant level rises. It falls again when the system cools. If it falls below the **KALT / COLD** mark when the system is cold, top up to the mark.

Top up anti-freeze. If no anti-freeze is available, top up with clean tap water. If tap water is unavailable, distilled water can be used.

When you top up with tap water or distilled water, add concentrated anti-freeze and possibly mix in anti-freeze as well. Have the reason for the loss of coolant rectified by a workshop.

Too low a coolant level can cause engine damage.

To close, position the cap and screw it into place.

Coolant temperature

Control indicator  illuminates when coolant temperature is too high. Check coolant level immediately:

- Coolant level too low:
Top up coolant: see the instructions under "Anti-freeze and corrosion protection" and "Coolant level". Have the reason for the loss of coolant rectified by a workshop.
- Coolant level correct:
Have the reason for the high coolant temperature rectified. Seek the assistance of a workshop.

Brake fluid

Brake fluid level

Warning

Brake fluid is poisonous and corrosive. Do not allow it to contact eyes, skin, fabrics or painted surfaces. Direct contact may cause injuries and damage.



The fluid level in the container must be neither higher than the **MAX** mark nor lower than the **MIN** mark.

There are brake fluids which could lead to damage or reduced braking when used. Therefore, we recommend that you use, where necessary, only approved high performance brake fluid.

When topping up, ensure maximum cleanliness as contamination of the brake fluid can lead to function problems in the braking system.

Once the brake fluid level has been corrected, have the reason for the loss of brake fluid rectified by a workshop.

Brake fluid change

Brake fluid is hygroscopic, i.e. it absorbs water. If the brakes become hot, such as when driving on long downhill stretches, vapour bubbles can occur in the water, which can have an extremely adverse effect on braking power (depending on the proportion of water).

The fluid change intervals specified in the Service Booklet must therefore be observed.

Warning

Have your brake fluid changed at a workshop. Observe legal requirements – regarding protection of your health and the environment – when disposing of used oil and engine oil filters.

Windscreen wiper

Clear vision is essential for safe driving.

Perform regular checks on the windscreen wiper and headlight wash system * to ensure they are operating correctly. We recommend wiper blade replacement at least once a year.

If the windscreen is dirty, operate the windscreen wash system before switching on the windscreen wiper or setting the wiper to automatic operation with the rain sensor *. This will avoid wiper blade wear.

Do not switch on the windscreen wiper or set it to automatic operation with the rain sensor * if the windscreen is iced up, as this could damage the wiper blades or the wiper system.

We recommend that you release a frozen windscreen wiper using de-icer spray before starting the vehicle, to prevent wiper motor damage.

Smearing wiper blades can be cleaned with a soft cloth and Vauxhall Windscreen Wash Solvent.

Wiper blades whose lips have become hardened, cracked or covered with silicone must be replaced. This may be necessary as a result of the effects of ice, thawing salt or heat, or the incorrect use of cleaning agents.

Switch off the windscreen wiper or automatic wiper with rain sensor * in car washes – see pages 11, 12, 195.

Windscreen wiper care – see page 197.



To ensure proper operation of the rain sensor *, the sensor area must be free from dust, dirt and ice, which is why the windscreen wash system must be operated at regular intervals and the sensor area de-iced. Vehicles with a rain sensor * can be identified by the sensor area near the top of the windscreen.

Service setting for front windscreen wiper



(e.g. for changing or cleaning the front wiper blades).

Within 4 seconds of turning off the ignition, with the key still in the starter switch or for the Open&Start system * after switching off the ignition and before opening the driver's door, press the wiper stalk down. Release wiper stalk as soon as the wiper is vertical.

Wiper blades on the windscreen



17499 T

Activating service position, see previous column. Lift wiper arm, push both bars on wiper arm, release wiper blade and remove.

Wiper blade on the rear window



17318 T

Lift wiper arm. Disengage wiper blade as shown in Fig. 17318 T and remove.

Windscreen and headlight wash systems *



17500 T

The fluid reservoir filler neck for the windscreen wash system and headlight wash system * is located at the front next to the left headlight.

Capacities – see pages 224, 225.

Fill only with clean water to prevent the nozzles from clogging. To improve cleaning efficiency, we recommend that you add a little Vauxhall Windscreen Wash Solvent.

The windscreen wash system and headlight wash system will not freeze in winter:

Frost protection down to	Mixture strength Vauxhall Windscreen Wash Solvent: Water
- 5 °C	1: 3
- 10 °C	1: 2
- 20 °C	1: 1
- 30 °C	2: 1

When closing the container, press the lid firmly over the beaded edge all the way round.

Battery



17320 T

The battery is maintenance-free.

 **Warning**

Have your battery changed at a workshop. Observe legal requirements – regarding protection of your health and the environment – when disposing of old batteries.

The battery may be placed under additional load or discharged by retro-fitting electric or electronic accessories. Seek advice on technical options, e.g. having a stronger battery fitted.

Laying up the vehicle for more than 4 weeks can lead to battery discharge, which may reduce the service life of the battery. Disconnect battery from on-board power supply by detaching negative terminal.

The Vauxhall alarm system * siren must be deactivated as follows: switch the ignition on then off, disconnect the vehicle's battery within 15 seconds.

Ensure that ignition is switched off before connecting battery. Then perform the following actions:

- Setting date and time in the information display – see pages 90, 93, 97.
- Activate window * if necessary – see page 48.

In order to prevent the battery from discharging, some consumers such as the courtesy light automatically switch off after approx. 10 minutes.

Disconnecting / connecting the battery from / to the electrical system

Before charging, disconnect the battery from the electrical system: remove the negative cable first, then the positive.

The battery poles, i.e. the connections for the positive and negative cables, must not be confused. When connecting, connect the positive cable first, then the negative.

Protection for electronic components

In order to prevent faults in electronic components in the electrical system, never connect or disconnect battery with engine running or ignition switched on. Never start engine with battery disconnected, e.g. when starting using jump leads.

To avoid damaging the vehicle, do not make any modifications to the electrical system, e.g. connecting additional consumers or tampering with electronic control units (chip tuning).

 **Warning**

Electronic ignition systems use a very high voltage. Do not touch the ignition system; danger to life.

Vehicle decommissioning

Observe national regulations.

If the vehicle is to be laid up for several months, the following work should be undertaken by a workshop in order to prevent damage.

- Wash and preserve the vehicle – see page 195.
- Check preservation in engine compartment and on underbody and rectify where necessary.
- Clean and preserve rubber seals on bonnet and doors.
- Change engine oil – see page 203.
- Check anti-freeze and corrosion protection – see page 204.
- Check the coolant level, top up with anti-freeze if necessary – see page 204.
- Empty windscreen wash system and headlight wash system.
- Increase tyre pressure to value specified for full load – see page 220.

Vehicle storage

- Park vehicle in a dry, well ventilated place. With manual transmission or Easytronic ✱, engage 1st or reverse gear. With automatic transmission ✱, selector lever in P. Use chocks or the like to prevent the vehicle from rolling.
- Do not apply handbrake.
- Disconnect battery by disengaging negative terminal from vehicle electrical system – see page 207.

Vehicle recommissioning

Observe national regulations.

Perform the following work before recommissioning the vehicle:

- Connect battery – see page 207.
- Check tyre pressure and correct if necessary – see page 220.
- Fill up windscreen wash system and headlight wash system – see page 207.
- Check engine oil level – see page 202.
- Check the coolant level; top up with anti-freeze if necessary – see page 204.
- Fit the number plate if necessary.

Technical Data

Vehicle documents, identification plate..... 210

Vehicle identification data..... 211

Coolant, brake fluid, oils 211

Engine data..... 212

Performance..... 214

Fuel consumption, CO₂ emissions 215

Weights, payload and roof load..... 217

Tyres 220

Electrical system 223

Capacities 224

Dimensions..... 226

Installation dimensions of trailer towing equipment..... 227

Permissible options for fitting a child restraint..... 228

Vehicle documents, identification plate



The technical data is determined in accordance with European Community standards. We reserve the right to make modifications. Specifications in the vehicle documents always have priority over those given in this manual.

The identification plate is affixed to the front right door frame.



Information on identification plate:

- 1 Manufacturer
- 2 Type approval number
- 3 Vehicle Identification Number
- 4 Permissible Gross Vehicle Weight
- 5 Permissible Gross Train Weight
- 6 Maximum permissible front axle load
- 7 Maximum permissible rear axle load
- 8 Vehicle-specific or country-specific data

Vehicle identification data



The Vehicle Identification Number is stamped on the identification plate and on the right side of the vehicle floor, under a cover between the front door and the seat.

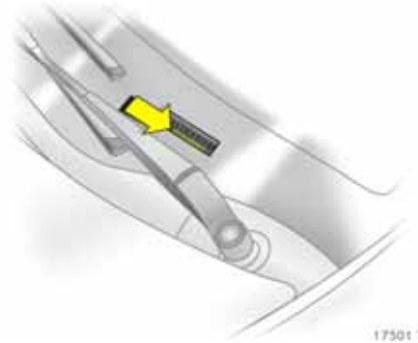

The Vehicle Identification Number may be embossed on the instrument panel.

Engine code and engine number: stamped on left-hand side of engine on crankcase.

Coolant, brake fluid, oils

Use approved fluids only.

Use of unsuitable fluids could cause serious damage to the vehicle.

Engine oils

Information on engine oils is available in the Service Booklet.

Engine data

Sales designation	1.6	1.6	1.8	2.0 Turbo	2.0 Turbo	2.2
Engine identifier code	Z 16 XEP	Z 16 XE1	Z 18 XER	Z 20 LER	Z 20 LEH	Z 22 YH
Number of cylinders	4	4	4	4	4	4
Piston displacement (cm ³)	1598	1598	1796	1998	1998	2198
Brake horse power (kW) at rpm	77 6000	77 6000	103 6300	147 5400	177 5600	110 5600
Torque (Nm) at rpm	150 3900	150 3900	175 3800	262 4200	320 2400-5000	215 4000
Fuel type ¹⁾	Petrol	Petrol	Petrol	Petrol	Petrol	Petrol
Octane requirement (RON) ²⁾ unleaded	95 ³⁾	95 ³⁾	95 ³⁾	95 ³⁾	95 ³⁾⁵⁾	95 ³⁾
or unleaded	98 ³⁾	98 ³⁾	98 ³⁾	98 ³⁾	98 ³⁾	98 ³⁾
or unleaded	91 ³⁾⁴⁾	91 ³⁾⁴⁾	91 ³⁾⁴⁾	91 ³⁾⁴⁾	91 ³⁾⁶⁾	— ⁷⁾
Max. permissible engine speed, continuous (rpm) approx.	6500	6500	6400	6400	6400	6500
Oil consumption (l/1000 km)	0.6	0.6	0.6	0.6	0.6	0.6

1) Standard high-quality fuels, unleaded DIN EN 228.

2) Standard high-quality fuels. Value printed in bold: recommended fuel.

3) Knock control system automatically adjusts ignition timing according to type of fuel used (octane number).

4) Use of 91 RON fuel reduces power and torque.

5) Use of 95 RON fuel reduces power and torque. Slight increase in fuel consumption.

6) If no unleaded premium fuel is available, 91 RON can be used, taking care to avoid high engine load or full load as well as driving in mountainous terrain with a caravan / trailer load or high payload.

7) The use of fuel with an octane of 91 RON is not permitted.

Engine data

Sales designation	1.9 CDTI	1.9 CDTI
Engine identifier code	Z 19 DT	Z 19 DTH
Number of cylinders	4	4
Piston displacement (cm ³)	1910	1910
Brake horse power (kW) at rpm	88 3500	110 4000
Torque (Nm) at rpm	280 2000-2750	320 2000-2750
Fuel type ¹⁾	Diesel	Diesel
Cetane requirement (CN) ²⁾	49 (D) ³⁾	49 (D) ³⁾
Max. permissible engine speed, continuous (rpm) approx.	5200	5200
Oil consumption (l/1000 km)	0.6	0.6

¹⁾ Standard high-quality fuels, diesel DIN EN 590

²⁾ Standard high-quality fuels: D = Diesel

³⁾ A lower value is possible with winter diesel fuels.

Performance

(approx. mph/km/h)

Engine ¹⁾	Z 16 XEP	Z 16 XE1	Z 18 XER	Z 20 LER	Z 20 LEH	Z 22 YH
Maximum speed ²⁾						
Manual transmission	110/177	110/177	122/197	140/225	144/231	124/200
Easytronic	–	–	122/197	–	–	–
Automatic transmission	–	–	–	–	–	118/190
Engine ¹⁾					Z 19 DT	Z 19 DTH
Maximum speed ²⁾						
Manual transmission					116/186	126/202
Easytronic					–	–
Automatic transmission					113/182	123/198

¹⁾ Sales designation – see pages 212, 213.

²⁾ The maximum speed indicated is achievable at kerbweight (without driver) plus 200 kg payload. Optional equipment could reduce the specified maximum speed of the vehicle.

Fuel consumption, CO₂ emissions

Directive 80/1268/EEC (last changed by 1999/100/EC) has applied for the measurement of fuel consumption since 1996.

The directive is oriented to a actual driving practices: Urban driving is rated at approx. $\frac{1}{3}$ and extra-urban driving with approx. $\frac{2}{3}$ (urban and extra-urban consumption). Cold starts and acceleration phases are also taken into consideration.

The specification of CO₂ emission is also a constituent of the directive.

The figures given must not be taken as a guarantee for the actual fuel consumption of a particular vehicle.

All values are based on the EU base model with standard equipment.

The calculation of fuel consumption as specified by directive 1999/100/EC takes account of the vehicle's kerbweight, ascertained in accordance with these regulations. Optional extras may result in slightly higher fuel consumption and CO₂ emission levels than those quoted.

To convert l/100 km into mpg, divide 282 by number of litres/100 km.

Saving fuel, protecting the environment – see page 143.

Fuel consumption (approx. l/100 km), **CO₂ emission** (approx. g/km) (up to tyre width 195 mm)

Engine ¹⁾	Z 16 XEP	Z 16 XE1	Z 18 XER	Z 20 LER	Z 20 LEH	Z 22 YH
Manual transmission/Easytronic/Automatic transmission						
Urban	9.3/-/-	9.3/-/-	10.1/ 9.9/-	-/-/-	-/-/-	-/-/-
Extra-urban	5.8/-/-	5.8/-/-	6.2/ 6.0/-	-/-/-	-/-/-	-/-/-
Total	7.1/-/-	7.1/-/-	7.6/ 7.4/-	-/-/-	-/-/-	-/-/-
CO ₂	170/-/-	170/-/-	182/ 178/-	-/-/-	-/-/-	-/-/-
					Z 19 DT	Z 19 DTH
Manual transmission/Easytronic/Automatic transmission						
Urban					-/-/-	-/-/-
Extra-urban					-/-/-	-/-/-
Total					-/-/-	-/-/-
CO ₂					-/-/-	-/-/-

Fuel consumption (approx. l/100 km), **CO₂ emission** (approx. g/km) (up to tyre width 225 mm)

Engine ¹⁾	Z 16 XEP	Z 16 XE1	Z 18 XER	Z 20 LER	Z 20 LEH	Z 22 YH
Manual transmission/Easytronic/Automatic transmission						
Urban	9.5/-/-	9.5/-/-	10.3/10.1/-	13.3/-/-	13.4/-/-	11.3/-/11.6
Extra-urban	6.0/-/-	6.0/-/-	6.4/ 6.2/-	7.3/-/-	7.4/-/-	6.4/-/ 6.7
Total	7.3/-/-	7.3/-/-	7.8/ 7.6/-	9.5/-/-	9.6/-/-	8.2/-/ 8.5
CO ₂	175/-/-	175/-/-	187/ 182/-	228/-/-	230/-/-	197/-/204
					Z 19 DT	Z 19 DTH
Manual transmission/Easytronic/Automatic transmission						
Urban					7.5/-/9.7	7.6/-/ 9.7
Extra-urban					5.0/-/5.6	5.1/-/ 5.6
Total					5.9/-/7.1	6.0/-/ 7.1
CO ₂					159/-/192	160/-/192

1) Sales designation – see pages 212, 213.

Weights, payload and roof load

The payload is the difference between the permitted Gross Vehicle Weight (see identification plate, page 210) and the EC kerbweight.

To calculate the kerbweight, enter the data for your vehicle below:

- Kerbweight from
Table 1, page 218 +..... kg
- Additional weight of
optional extras from
Table 2, page 219 +..... kg
- Weight of heavy
accessories from
Table 3, page 219 +..... kg
- Total =..... kg

is the EC kerbweight.

Optional equipment and accessories increase the kerbweight, which means that the payload will also change slightly.

Note the weights given in the vehicle documents.

The combined total of front and rear axle loads must not exceed the permissible Gross Vehicle Weight. For example, if the front axle is bearing its maximum permissible load, the rear axle can only bear a load that is equal to the Gross Vehicle Weight minus the front axle load.

When the caravan / trailer is coupled and the towing vehicle fully loaded (including all occupants), the permissible rear axle load (see identification plate or vehicle documents) may be exceeded by 90 kg and the Gross Vehicle Weight rating by 75 kg. If the permissible rear axle load is exceeded, a maximum speed of 60 mph (100 km/h) applies. If national regulations specify a lower maximum speed for vehicles towing a caravan / trailer, this must be observed.

For permitted axle loads, see identification plate and vehicle documents

Roof load

The permissible roof load is 75 kg. The roof load consists of the weight of the roof rack plus the load carried.

Driving hints – see page 141.

Roof racks, caravan and trailer towing – see page 164.

Table 1, Kerbweight in kg¹⁾

Model	Engine ²⁾	Manual transmission	Easytronic	Automatic transmission
Zafira	Z 16 XEP	1505	–	–
	Z 16 XE1	1505	–	–
	Z 18 XER	1503	1503	–
	Z 22 YH	1570	–	1595
	Z 19 DT	1613	–	1643
	Z 19 DTH	1613	–	1643
	Zafira with air conditioning system or Electronic Climate Control (ECC)	Z 16 XEP	1520	–
Z 16 XE1		1520	–	–
Z 18 XER		1518	1518	–
Z 20 LER		1610	–	–
Z 20 LEH		1665	–	–
Z 22 YH		1585	–	1610
Z 19 DT		1628	–	1658
Z 19 DTH		1628	–	1658

¹⁾ According to EC Directive, including assumed weights for driver (68 kg), luggage (7 kg) and all fluids (tank 90 % full).

²⁾ Sales designation – see pages 212, 213.

Table 2, Additional weight of optional extras in kg

Engine ¹⁾	Z 16 XEP	Z 16 XE1	Z 18 XER	Z 20 LER	Z 20 LEH
Expression / Life	10	10	10 ²⁾	–	–
Design	–	–	23	16	–
SRi	–	–	20	13	–
Club	12	12	12	–	–
VXR	–	–	–	–	3)

Engine ¹⁾	Z 22 YH	Z 19 DT	Z 19 DTH
Expression / Life	5 ²⁾	5 ²⁾	–
Design	16	16	16
SRi	13	13	13
Club	5	5	–
VXR	–	–	–

Table 3, Heavy accessories in kg

Accessories	Towing equipment	Adaptive Forward Lighting (AFL)	Headlight wash system	Panoramic roof system
Weight	17	4	3	35

¹⁾ Sales designation – see pages 212, 213.

²⁾ Life only.

³⁾ Values not available at time of printing.

Tyres

Restrictions

Tyres of size 225/45 R 17 may only be used in conjunction with the Electronic Stability Programme (ESP) *.

Not all tyres available on the market currently meet the structural requirements. We recommend that you consult a Vauxhall Authorised Repairer concerning suitable tyre makes.

These tyres have undergone special tests to establish their reliability, safety and specific suitability for Vauxhall vehicles. Despite continuous market monitoring, we are unable to assess these attributes for other tyres, even if they have been granted approval by the relevant authorities or in some other form.

Further information – see page 159.

Wheels

Wheel bolt tightening torque: 110 Nm.

Winter tyres *

Tyres of size 225/40 R 18 and 235/35 R 19 are not permitted for use as winter tyres.

If you use winter tyres, the spare wheel * may still be fitted with a summer tyre. If you use the spare wheel the vehicle's handling may be altered. Obtain a replacement for the faulty tyre as soon as possible, and have the wheel balanced and fitted to the vehicle.

Winter tyres may only be used on the Zafira VXR on special alloy wheels approved by Vauxhall.

Further information – see page 159.

Tyre chains *

Tyre chains may be used on the front wheels only.

We recommend the use of fine tyre chains which rest by a maximum of 10 mm on the tyre tread and on the insides of the tyres with a chain lock.

Tyre chains are not permitted on tyres of size 225/40 R 18 and 235/35 R 19.

Further information – see page 159.

Spare wheel *

Depending on the version, the spare wheel may take the form of a temporary spare wheel *: vehicle driveability may be altered by use of the spare wheel. Obtain a replacement for the faulty tyre as soon as possible, and have the wheel balanced and fitted to the vehicle. Observe the notes on this page and on pages 164, 176.

On vehicles with alloy wheels *: the spare wheel may have a steel rim.

The spare wheel may be fitted with a smaller tyre and smaller wheel than the wheels fitted to the vehicle.

Tyre pressure in bar / psi¹⁾

The specified tyre pressures are valid for cold tyres. The increased tyre pressure resulting from extensive driving must not be reduced. The tyre pressures specified on the following pages apply to both summer and winter tyres.

Always inflate the spare wheel * to the tyre pressure for full load, see tables on following pages.

Temporary spare wheel tyre pressure *, see tables on next pages.

In vehicles with Tyre Pressure Monitoring System * there is an adapter in the valve cap key. Screw adapter to valve before attaching tyre pressure gauge – see page 160.

Further information – see pages 159 to 163.

¹⁾ 1 bar corresponds to 100 kPa / 14.5 psi.

Continued:

Tyre pressure in bar / psi¹⁾

Engine ²	Tyres	Tyre pressure with load of up to 3 people		Tyre pressure ECO ¹⁾ loaded up to 3 people		Tyre pressure with full load	
		Front	Rear	Front	Rear	Front	Rear
Z 16 XEP, Z 16 XE1, Z 18 XER	195/65 R 15, 205/55 R 16, 225/45 R 17	2.0/29	2.0/29	2.5/36	2.5/36	2.1/30	2.6/38
	225/40 R 18	2.2/32	2.2/32	–	–	2.3/33	2.8/41
Z 22 YH	205/55 R 16, 225/45 R 17	2.2/32	2.0/29	2.6/38	2.6/38	2.4/35	2.9/42
	225/40 R 18	2.4/35	2.2/32	–	–	2.5/36	3.0/44
Z 20 LER	205/55 R 16, 225/45 R 17	2.5/36	2.3/33	–	–	2.6/38	3.1/45
	225/40 R 18	2.6/38	2.4/35	–	–	2.8/41	3.2/46
All	Spare wheel (temporary spare wheel) ³⁾	4.2/61	4.2/61	–	–	4.2/61	4.2/61

¹⁾ To achieve the smallest amount of fuel consumption possible. Not for use with run-flat tyres.

²⁾ Sales designation – see pages 212, 213.

³⁾ For notes on the temporary spare wheel – see page 176.

¹⁾ 1 bar corresponds to 100 kPa / 14.5 psi.

Continued:

Tyre pressure in bar / psi¹⁾

Engine ²⁾	Tyres	Tyre pressure with load of up to 3 people		Tyre pressure ECO ¹⁾ loaded up to 3 people		Tyre pressure with full load	
		Front	Rear	Front	Rear	Front	Rear
Z 20 LEH	205/50 R 17 ³⁾ , 225/45 R 17 ³⁾⁴⁾ , 225/40 R 18, 235/35 R 19	2.5/36	2.3/33	–	–	2.7/39	3.2/46
Z 19 DT, Z 19 DTH	195/60 R16	2.6/38	2.4/35	–	–	2.8/41	3.2/46
	205/55 R 16, 225/45 R 17	2.4/35	2.2/32	–	–	2.6/38	3.1/45
	225/40 R 18	2.5/36	2.3/33	–	–	2.7/39	3.1/45
Z 19 DTH ⁵⁾	205/55 R 16, 225/45 R 17	2.5/36	2.3/33	–	–	2.6/38	3.1/45
All	Spare wheel (temporary spare wheel) ⁶⁾	4.2/61	4.2/61	–	–	4.2/61	4.2/61

1) To achieve the smallest amount of fuel consumption possible. Not for use with run-flat tyres.

2) Sales designation – see pages 212, 213.

3) Only permitted as winter tyres.

4) To guarantee a correct speed display, the electronic speedometer must be reprogrammed.

5) Version with automatic transmission and panoramic roof.

6) For notes on the temporary spare wheel – see page 176.

1) 1 bar corresponds to 100 kPa / 14.5 psi.

Electrical system

Battery	Voltage	12 Volt
	Amp hours	44 Ah / 55 Ah * / 60 Ah * / 66 Ah * / 70 Ah *

Battery for remote control of central locking system and electronic key of Open&Start system CR 20 32

Capacities

(approx. litres)

Engine¹⁾	Z 16 XEP	Z 16 XE1	Z 18 XER	Z 20 LER	Z 20 LEH	Z 22 YH
Fuel tank (nominal content)	56	56	56	56	56	56
Engine oil with filter change	4.5	4.5	4.5	4.25	5.0	5.0
between MIN and MAX on dipstick	1.0	1.0	1.0	1.0	1.0	1.0
Wash fluid reservoir for windscreen wash system	2.3	2.3	2.3	2.3	2.3	2.3
with headlight wash system	4.2	4.2	4.2	4.2	4.2	4.2

¹⁾ Sales designation – see pages 212, 213.

Capacities

(approx. litres)

Engine ¹⁾	Z 19 DT	Z 19 DTH
Fuel tank (nominal content)	56	56
Engine oil with filter change between MIN and MAX on dipstick	4.3 0.7	4.3 0.7
Wash fluid reservoir for windscreen wash system with headlight wash system	2.3 4.2	2.3 4.2

¹⁾ Sales designation – see pages 212, 213.

Dimensions

(approx. mm)

	Zafira	Zafira VXR
Overall length	4467	4503
Overall width	1801	1801
Width with two exterior mirrors	2025	2025
Overall height	1635	1635
Height with panoramic roof	1670	1670
Luggage compartment length at floor	1088	1088
Luggage compartment width	1071	1071
Height of luggage compartment opening	895	895
Wheelbase	2703	2703
Turning circle diameter, wall to wall ¹⁾	11.50	11.85

¹⁾ In metres.

Installation dimensions of trailer towing equipment

All dimensions refer to factory-fitted towing equipment.

Warning

Only use towing equipment approved for your vehicle. We recommend entrusting retrofitting of towing equipment to a workshop.

Dimension **mm**

A 76.4

B 425.4

C 448.7

D 404.0

E 510.5

F 466.0

G 188.5

H 168.0

I 466.0

K 510.5

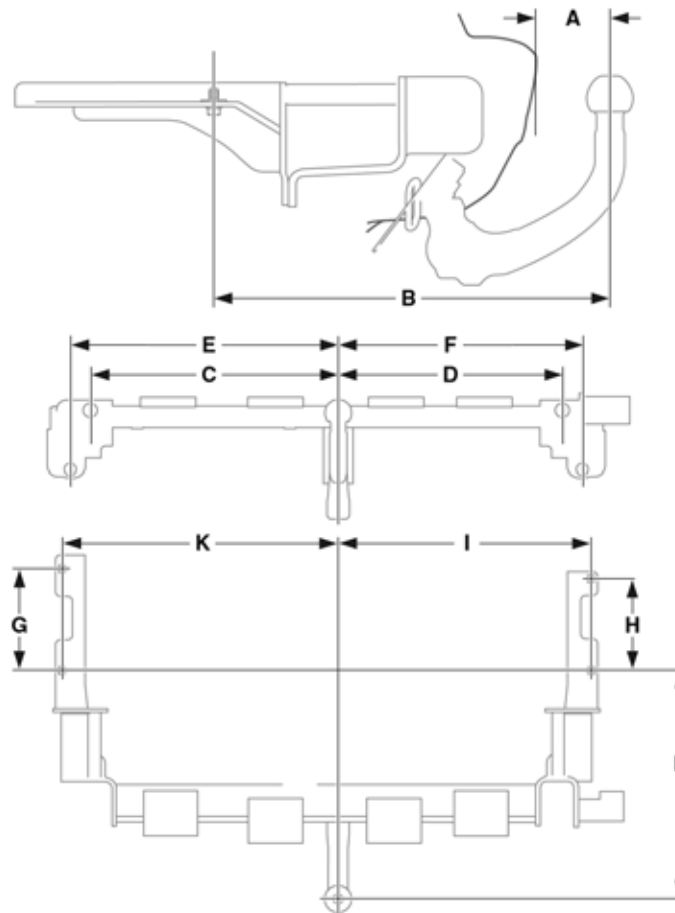

Permissible options for fitting a child restraint¹⁾

Weight and age class ²⁾	On front passenger's seat	On outboard seats in the second row	On centre seat in the second row	On the seats in the third row
Group 0: up to 10 kg or approx. 10 months	B ¹ , +	U, +	U	X
Group 0+: up to 13 kg or approx. 2 years				
Group I: 9 to 18 kg or approx. 8 months to 4 years	B ² , +	U, +, ++	U	UF
Group II: 15 to 25 kg or approx. 3 to 7 years	X	U	U	UF
Group III: 22 to 36 kg or approx. 6 to 12 years				

¹⁾ For reasons of safety, we recommend that the child restraint be installed on one of the outboard seats in the second row of seats.

²⁾ We recommend the use of each system until the child reaches the upper weight limit.

B¹ = Limited, only with seat occupancy recognition and Vauxhall child restraint system with transponders.

If the child restraint system is being secured using a three-point seat belt, move seat height adjustment * to uppermost position. Move front passenger's seat as far back as possible and move front passenger's seat belt anchorage point to lowest position.

B² = Limited, only with seat occupancy recognition and Vauxhall child restraint system with transponders.

If the child restraint system is being secured using a three-point seat belt, move seat height adjustment * to uppermost position. Move front passenger's seat as far back as possible so that vehicle safety belt runs from anchorage point towards the front.

U = Universal suitability in conjunction with three-point seat belt.

UF = Can be used universally for child restraint systems facing the front in combination with a three-point seat belt.

+ = Vehicle seat available with ISO-FIX attachments. When attaching using ISO-FIX, only the ISO-FIX child restraint systems permitted for the vehicle may be used.

++ = Vehicle seat available with ISO-FIX attachments. When attaching using ISO-FIX and Top Tether, universally permitted ISO-FIX child restraint systems may be used.

X = No child restraint system permitted in this weight class.

Index

A

ABS (Anti-lock Brake System)..... 159
 Accessories..... 174
 Accessory socket 78
 Adjust incline
 Seat50
 AFL (Adaptive Forward Lighting) 108
 Bulb replacement 191
 Driving abroad..... 111
 Air conditioning system 114, 119
 Air intake..... 130
 Air quality sensor..... 125
 Air recirculation system.....120, 123, 129
 Air vents 115
 Airbag system.....23, 69
 Airbags..... 69
 Alarm 44
 Alarm system..... 42
 Alternator..... 84
 Antenna 112, 195
 Anti-freeze 204
 Anti-freeze protection.....204, 207
 Anti-knock quality of fuel 144
 Octane number..... 212
 Anti-theft alarm system..... 42
 Anti-theft locking system 38
 Towing equipment 166
 Anti-theft protection 18
 Aquaplaning 162
 Armrest..... 52
 Ashtray..... 79, 110

Automatic air recirculation mode.126, 128
 Automatic anti-dazzle interior mirror..... 46
 Automatic level control..... 153
 Automatic transmission..... 14, 15, 136
 Automatic mode 137
 Control indicator..... 138
 Driving programme 138
 Fault 140
 Interruption of power supply..... 141
 Kickdown..... 139
 Manual mode 138
 Selector lever..... 14, 15, 137, 138
 Winter programme..... 139
 Automatic wiping..... 12, 103

B

Battery	142, 207, 223
Interruption of	
power supply	48, 135, 141
Battery discharge protection.....	110
Before starting-off	16
Belt force limiters	64
Belt tensioners.....	64
Bleeding, diesel fuel system.....	170
Board Information Display	89
Bonnet	170
Brake assist	157
Brake light	157
Brake system	84
Brakes	
ABS	159
Brake assist	157
Brake fluid	205
Brake lights.....	191
Brake servo unit	141
Footbrake	157
Handbrake	158
Bulb replacement	187
Bulbs	187

C

Capacities	224
Car Pass	30
Caravan / trailer towing	141, 167
Care	194
Catalytic converter	146, 148, 171
Central locking system	37
Changing the battery	
Remote control	33, 37, 223
Changing tyre / wheel type	159
Changing wheels	176
Chassis number,	
see vehicle identification number	211
Check control	25, 101
Child restraint systems	68, 228
Child safety locks.....	45, 47
Cigarette lighter	78, 110
Climate control	114
Clutch operation.....	142
CO ₂ emissions	215
Cold start	142
Colour Information Display	89
Continuous Damping Control.....	85, 150
Contrast.....	98

Control indicators.....	8, 82, 83
ABS (Anti-lock Brake System).....	159
AFL (Adaptive Forward Lighting).....	87, 108
Airbag	73
Belt tensioners	64
Brake system.....	158
Cruise control.....	151
DDS (Deflation Detection System) ...	154
Engine electronics.....	147
ESP (Electronic Stability Program)....	148
Exhaust.....	147
IDS+	
(Interactive Driving System)	150, 151
Immobiliser	31
Parking distance sensors	153
Transmission	138
Tyre pressure monitoring system	156
Coolant	204
Coolant level.....	204
Coolant temperature	84
Cooled glove compartment	117
Cooling	120, 124
Correcting time.....	92, 97
Corrosion protection	196, 201
Coupling socket load	167
Courtesy lights	109
Bulb replacement	193
Cruise control.....	151
Curtain airbags	72
Curve lighting (AFL)	29, 108

D

Data 30, 210
 Date 90, 93
 Daytime running lights 105
 DDS (Deflation Detection System) .. 28, 154
 Decommissioning 208
 Demisting and defrosting 119
 With air conditioning system 120, 124
 With Electronic Climate Control 127
 Diesel fuel filter 203
 Diesel fuel system 170, 203
 Diesel particle filter..... 86, 116, 142
 Dimensions..... 225, 226
 Dipped beam 10
 Bulb replacement 188
 Display 88, 89
 Display instruments 87
 Display mode 98
 Door handle lighting 110
 Door locks..... 30, 196
 Doors 84
 Door-to-door lighting 108
 Drink holders 81
 Driving abroad 144, 199
 Driving hints 141

E

Easytronic 14, 131
 Driving programmes 133
 Fault 135
 Interruption of power supply 135
 Kickdown 134, 135
 Selector lever 14
 Starting-off 132
 Winter programme 133
 Economical driving 143
 Electric windows 46
 Electrical system 182, 208, 223
 Electro-hydraulic
 power-assisted steering 141
 Electronic Climate Control 115, 124
 Electronic components 208
 Electronic immobiliser 30
 Electronic Stability Program 148
 Engine code 211, 212, 213
 Engine control indicator 147
 Engine oil 202
 Engine oil change 203
 Engine oil level and consumption ... 85, 202
 Engine speed 142
 Engine wash 196
 Entry lighting 110
 Environmental protection 194, 203
 ESP (Electronic Stability Program) 148
 Exhaust control indicator 147
 Exhaust gases 148
 Exhaust system 148
 Exterior mirrors 5, 45, 116

F

Fan 117, 201
 Filling station
 Capacities 224, 225
 Engine oil level 202
 Fuel 144, 212, 213
 Opening the bonnet 170
 Tyre pressure 144, 220
 Vehicle data 211
 Windscreen wash system 207
 First-aid kit (cushion) 174
 Flat tyre 179
 Flex Organizer 60
 Fog tail light 107
 Bulb replacement 191
 Footbrake 157
 Front fog lights 106
 Bulb replacement 191
 Front passenger's airbag 69
 Fuel 145, 212, 213
 Fuel consumption 143, 144, 215
 Fuel filler cap 145
 Fuel filter 203
 Fuel level 88
 Fuel system, diesel 170
 Fuse extractor 183
 Fuses 182

G

Gears	14
Generator – see Alternator	84
Genuine Vauxhall Parts and Accessories	201
Glasses compartment	80
Glove compartment	80, 117
Glove compartment lighting	110
Bulb replacement	194
Graphical Information Display	89
Gross Vehicle Weight.....	217

H

Halogen headlight system	188
Bulb replacement	188
Driving abroad	111
Handbrake.....	17, 18, 158
Hazard warning lights	11, 107
Head restraints	24, 51, 52
Head light flash	10, 105
Head light range adjustment	107, 187
Head light switch	10, 105, 106
Head light wash system	12, 103, 207
Head lights.....	10
Daytime running lights	105
Driving abroad	111
Reversing lights.....	107
Warning device.....	102
Heated exterior mirrors.....	13, 116
Heated rear window	13, 116
Heated seats.....	116
Heating	114, 118
Seats	116
With air conditioning system	120, 124
With Electronic Climate Control	126
Height adjustment	
Seat belts.....	66
Steering wheel	9
High-pressure jet	167, 197
Hill Start Assist	158
Horn.....	11

I

Identification plate.....	210
IDS+ (Interactive Driving System) ..	148, 150
Ignition logic.....	93, 98
Ignition system	201, 208
Immobiliser	30
Information display	89
Infotainment system	112, 113
Inspection system	88, 200
Instrument illumination	109
Bulb replacement	194
Instruments	82
Interior mirror.....	5, 46
Interruption of power supply ...	48, 100, 102
Easytronic.....	135
Electric windows	48
Selector lever lock	141
ISO-FIX	68

J

Jack174, 177
Jump leads 171

K

Keys30
 Extending30
 Locking doors.....37
 Remove 18
 Starter switch 9
 Starting the engine 9, 16, 17

L

Language selection93, 97
Lashing eyes 60
Leather trim 196
Light switch 10
Lighting 10, 85, 105
 Driving abroad 111
Load compartment –
 see Luggage compartment 41
Loading 167, 217
Locking doors2, 37
Locking from the inside 39
Locks 196
Lubricants 202, 211
Luggage compartment
 Bulb replacement 194
 FlexOrganizer 60
 Lashing eyes 60
 Lighting 110
 Loading62, 167, 217
 Locking 41
Luggage compartment cover57, 58
Luggage compartment extension 54
Lumbar support..... 50

M

Main beam 10, 105
 Bulb replacement 189
 Control indicator 86
Maintenance
 Air conditioning system 130
 Anti-freeze protection 204
 Brake fluid 205
 Brakes 157
 Catalytic converter 148
 Engine oil 202
 Fuel consumption 144
 Tyre pressure 160
 Tyres 161, 162
 Windscreen wiper 206
Manual transmission – see Transmission 14
Mirrors 5, 45, 46
Misted windows 13, 119, 127
Mobile telephone 113
Motorway lighting (AFL)29, 108

N

- Neutral, transmission 14
- Number plate lighting 193
 - Bulb replacement 193
- Number plates 209

O

- Octane numbers 144, 212
- Odometer 87
- Oil change 203
- Oil level and consumption 202
- Oils 202
- Open&Start system 17, 26, 33, 83
- Operating temperature 142
- Outside temperature gauge 90
- Overrun 142, 143

P

- Paintwork damage 196
- Panoramic roof 48, 195
- Parking distance sensors 27, 152
- Parking 18, 152
- Parking lights 10, 109
 - Bulb replacement 189
- Parts 201
- Pedals 142
- Performance 215
- Petrol 144, 212, 213
- Pinking 144
- Pollen filter 129, 130
- Power steering, see electro-hydraulic
 - power-assisted steering 141
- Preheating 17, 86
- Puddle light 110
- Pushing, towing 171

Q

- Quickheat 118, 123, 126

R

- Radio 112
- Radio equipment (CB) 113
- Radio reception 112
- Rain sensor 12, 103, 206
- Reading lights 110
- Rear light cluster 105
 - Bulb replacement 191
- Rear seat backrests 20
- Rear window
 - wash system 12, 104, 195, 207
- Rear window wiper 104
- Refuelling 145
 - Fuel filler cap 146
- Remote control
 - Central locking system 2, 26, 32, 34
 - Luggage compartment 3
 - Steering wheel 26, 112
- Replacement keys 30
- Reversing lights
 - Bulb replacement 191
- Roof load 63, 142, 144, 217
- Roof racks 144, 164, 217
- Run-flat tyres (RFT) 163
- Running-in 141
 - Brakes 157

S

Safeguard against unauthorised use	9, 19
Safety net	58
Saving energy	143
Seat adjustment	3, 49
Seat belts	63, 65, 196
Seat height adjustment	4, 49
Seat occupancy recognition	74
Seat position	50
Seats	3, 49, 50
Heated	116
Seats in second row	20
Seats in third row	20, 53, 55
Selector lever	132, 137
Selector lever lock	14, 15, 137
Self-diagnosis	64, 74, 159
Self-help	170
Automatic transmission	140
Electric windows	48
Information display	90
Remote control	32, 37

Service	198
Service interval display	200
Service work	200
Side airbags	71
Silencer, see Exhaust system	148
Spare fuses	182
Spare keys	30
Spare wheel	175, 176
Speed	143, 144
Fuel consumption	143, 144
Speedometer	87
Sport mode	27, 85, 150
Starter switch	9
Starting the engine	9, 31, 131, 171
Self-help	171
Steam jet	167, 197
Steering column lock	9, 18
Steering wheel adjustment	9
Steering wheel remote control	26, 112
Stop watch	94
Stowage compartments	79, 80, 81
Sunvisors	81, 110
Sunblind	48
System settings	92, 96

T

Tables	79
Tachometer	87
Tail lights	105
Bulb replacement	191
Tailgate	41
Technical data	210
Telephone – see Mobile telephone	113
Temperature regulation	117, 126
Temporary spare wheel	164, 176, 220
The first 600 miles (1000 km)	141
Tightening torque	178, 220
Time	90, 93
Tools	174
Top-Tether	69
Towing	172
Towing equipment	164, 227
Towing eye	172, 173
Trailer / caravan towing	141, 167
Transmission display	88, 131, 136

Transmission, automatic.....14, 15, 136
 Automatic mode..... 137
 Driving programme 138
 Fault 140
 Interruption of power supply 141
 Kickdown 139
 Selector lever 14, 137, 138
 Selector lever lock 14
 Winter programme 139
 Transmission, Easytronic..... 131
 Driving programmes 133
 Fault 135
 Interruption of power supply 135
 Kickdown 134, 135
 Selector lever 14, 132
 Winter programme 133
 Transmission, manual 14
 Tread depth 162
 Trip computer 25, 93, 98
 Trip odometer 87
 Triple Information Display 89
 TSA (Trailer Stability Assist)..... 168
 Turn signals..... 10, 106
 Bulb replacement 190, 191
 Twin Audio 26, 112
 Tyre chains..... 163, 220
 Tyre condition 161
 Tyre pressure..... 28, 155, 160, 220
 Tyre pressure monitoring system 28, 155
 Tyre repair kit..... 179
 Tyres, wheels..... 159

U

Units of measure 93, 98
 Unleaded fuel 144, 146, 212
 Used oil..... 203

V

Valve cap key 161, 220
 Vehicle care 194
 Vehicle decommissioning 208
 Vehicle dimensions..... 226
 Vehicle Identification Number..... 211
 Vehicle keys – see Keys..... 30
 Vehicle recommissioning 209
 Ventilation..... 114, 118, 123, 127

W

Warning buzzers 102
 Warning messages..... 91, 95
 Warning triangle, 174
 Wash fluid reservoir,
 windscreen wash system..... 207
 Weights 217
 Wheels, tyres..... 159
 Windows
 Demisting
 and defrosting 13, 119, 120, 124, 127
 Windscreen wash system 12, 103
 Anti-freeze protection 207
 Capacities 224, 225
 Wash fluid reservoir 207
 Windscreen wiper 11, 102, 205
 Winter mode
 Starting-off aid 133
 Winter operation
 Battery 142
 Coolant, anti-freeze 204
 Fuel consumption 144
 Fuel for diesel engines 145
 Heating 114, 120, 124
 Locks 196
 Tyre chains..... 164, 220
 Window demisting and defrosting.... 119
 Windscreen wash system,
 anti-freeze protection 207
 Winter programme..... 133, 139
 Winter tyres..... 163, 220

X

Xenon headlight system

Bulb replacement..... 191

Driving abroad..... 111



©Copyright by Vauxhall Motors Ltd., England.

Reproduction or translation, in whole or in parts, is not permitted without prior written consent from Vauxhall Motors Ltd.

All rights as understood under the copyright laws are explicitly reserved by Vauxhall Motors Ltd.

All information, illustrations and specifications contained in this manual are based on the latest production information available at the time of publication.

The right is reserved to make changes at any time without notice.

Edition: January 2007.

TS 1639-B-07

