

# Corsa

2008 Models Edition 2





# C'MON!

## Put the fun back into driving

Get yourself into a Corsa. And get a lot more fun out of life. With stunning styling and brilliant attention to detail, inside and out. A dynamic chassis and punchy petrol or diesel engines. Plus bags of clever features. It can only make life better. Wherever you go. Whatever's in store for you.

*This brochure covers Corsa Expression, Life, Club, Design, SXi and SRi models only. Some of the models shown include options and accessories available at extra cost. And not all of the features described are available on every model. So please check in the Equipment section for further details. From time to time, we also offer alternative Corsa models such as Special Editions, featured in their own separate literature or found on the Vauxhall website: [www.vauxhall.co.uk](http://www.vauxhall.co.uk)*



Real style	6
Environmental issues	10
Driving dynamics	12
Safety and security	16
Great features	18
Corsa line-up	22
Options and accessories	30
Corsa VXR	36
Colours and trims	40
Equipment	44
Technical data	54







# C'MON Check the style

Corsa looks brilliant from every angle. The seriously sporty three-door, sharp and dynamic with real attitude. And the flexible five-door – maybe a little more grown-up, but ever so versatile and wonderfully well proportioned. On the inside, we've got sharp tailored fabrics, clean lines, modern surface finishes and chrome detailing. And every model has its own unique personality, so all you have to do is choose the one that matches yours.











# RESPECT your world.

We all share a responsibility to look after our world. That's why Vauxhall has been at the forefront of green automotive initiatives for many years. We are always looking to reduce vehicle CO<sub>2</sub> emissions, of course, and our EcoFlex models like the Corsa 1.3CDTi (75PS) have among the lowest vehicle CO<sub>2</sub> emissions in the UK.

But our commitment to preserving the environment goes even further. We are working on even cleaner, alternative power sources, including zero-emission fuel cell technology for example. We have dramatically reduced manufacturing emissions, and our new models use more recycled materials and more recyclable parts than ever before.

We also offer free and easily accessible, environmentally friendly, end-of-life vehicle disposal through our partners Autogreen Ltd. And under our EcoFlex Scrap Allowance\* programme, if you buy a selected low-emission Corsa model, we'll even offer you £1000 to take your old, higher emission car off the road.

That way, we reduce our environmental impact in every phase of every vehicle's life cycle. Because your world is our world, too.

\*Terms and conditions apply. Please ask your Retailer for details.





# C'MON!

## Enjoy the drive

The best way to discover how much fun Corsa is to drive is to try it for yourself. You certainly won't be disappointed. We've tuned the chassis for a great ride and secure, agile roadholding. Intelligent chassis safety features are available to help in emergency situations. And every Corsa engine – petrol or diesel – matches plenty of punch with remarkable fuel economy. Book that test drive today!

## A new dimension of driving fun

Okay, we could just tell you that the Corsa chassis has been designed to ensure pure driving pleasure without ever compromising ride comfort. But wouldn't it be better to discover how much fun it is to drive by trying it for yourself?

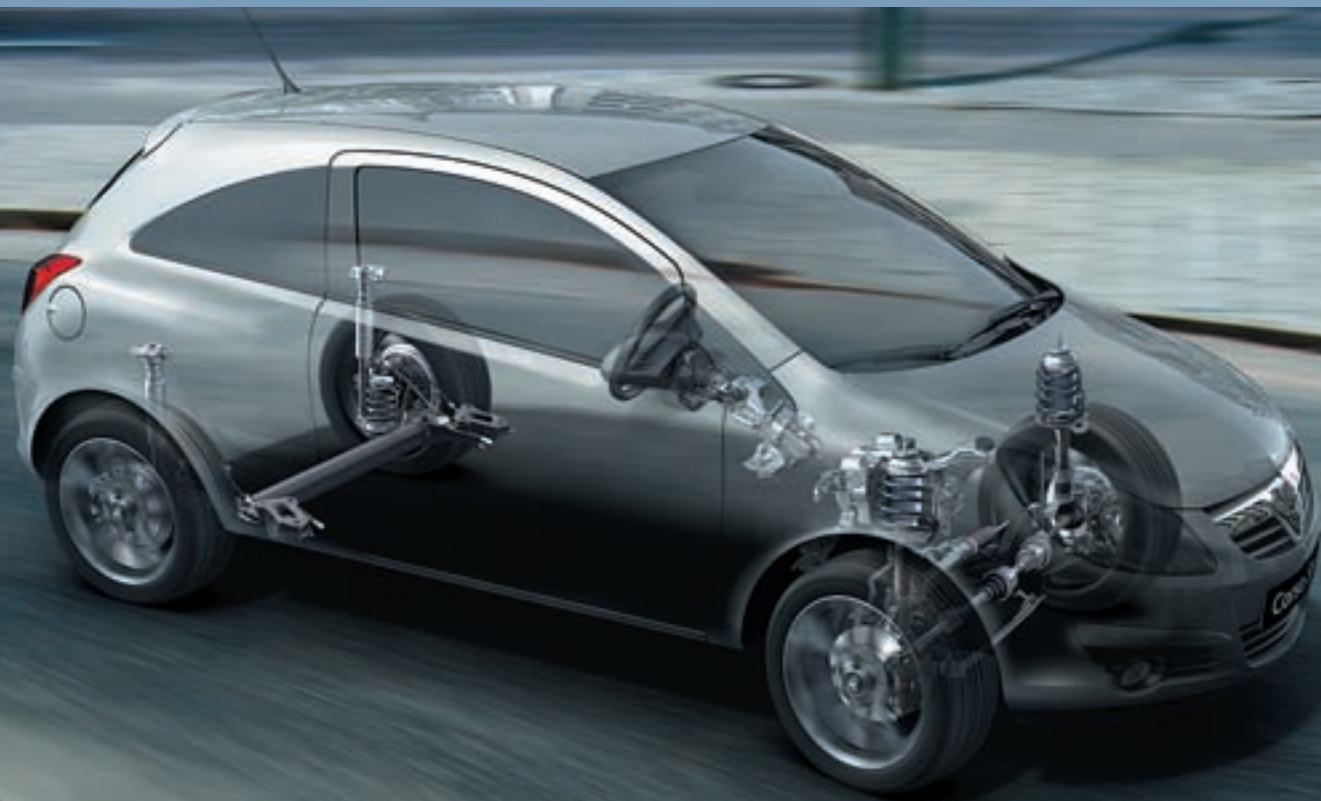



◀ **Easytronic.** Choose Corsa's optional Easytronic transmission and you'll get a five-speed manual gearbox with a fully automatic mode. In manual mode, you simply push the lever forward or back to shift gears up or down and by nudging the lever to the side you switch to fully automatic mode. There's no clutch pedal so you can drive it on an automatic-only driving licence.



▶ **Corsa EcoFlex models.** The Corsa EcoFlex models have among the lowest vehicle CO<sub>2</sub> emissions in the UK. Not only is the 1.3CDTi 16v (75PS) turbo-diesel engine fuel efficient it also ensures that EcoFlex models are eligible for the lower band B Vehicle Excise Duty charges.



▶ **New 1.6i 16v Turbo.** Available on SRI models only, this range-topping engine, with its turbocharger and intercooler, puts out an impressive 150PS and 210Nm maximum torque. Yet a high level of flexibility ensures it's equally at ease in traffic or at motorway speeds.

▶ **Six-speed and Auto.** Cars like Corsa never used to come with a six-speed manual gearbox, but the new 1.6i 16v Turbo petrol and 1.3CDTi 16v 90PS and 1.7CDTi 16v diesel models do. Others come with a five-speed manual as standard, with a sophisticated four-speed automatic also available.

▶ **Chassis.** The Corsa chassis combines serious ride comfort with real agility. The advanced anti-lock braking system has a number of sophisticated features and combines with other chassis safety features to improve stability and steering behaviour in a range of emergency situations.

Choose the sporty SXi or SRI – or the optional 17-inch alloy wheels on Design models – and you will enjoy a lower ride height and sportier spring and damper settings, plus progressive rate variable ratio speed-sensitive power steering.

▶ **Speed-sensitive steering.** With Corsa's power steering, it's easier to turn the wheel at parking speeds when you need it most, but more stable, with more feedback, once you're out on the road. The setup is even tuned to the specific engine to ensure the perfect level of assistance, with a progressive rate variable ratio system on SXi and SRI for an even sportier response.



▶ **Petrol engines.** Corsa models are available with 1.0i 12v, 1.2i 16v, 1.4i 16v and 1.6i 16v Turbo multi-valve petrol engines. Most feature our Twinport variable induction system and very much the same attitude, too. Big on flexibility with lively power delivery. Big on fuel economy. But low on emissions.

▶ **Turbo diesels.** Corsa's 1.3CDTi 16v – 75PS and 90PS – and 1.7CDTi 16v are low on emissions, with serious mid-range punch and incredible economy. How do we do it? Common rail injection, an intercooled turbocharger and plenty of Vauxhall know-how.



**▲ ABS and ESP-plus.** Corsa's Anti-lock Braking System (ABS) includes safety features like Straight Line Stability control and Cornering Brake Control as standard. Electronic Stability Programme (ESP-plus) is standard on SRi and optional on all other models. Turn to the Technical data on page 59 for more details.

  
[www.euroncap.com](http://www.euroncap.com)  
  
 Adult occupant rating

**▼ Airbags.** Most Corsa models feature double-action front seatbelt pretensioners and up to six airbags, including front seat side-impact and curtain airbags too. Press a button on the centre console to deactivate the front passenger's airbag and you can keep a rear-facing child seat up front.



**▼▶ Halogen AFL.** Another feature you don't expect on a car like Corsa, optional Halogen Adaptive Forward Lighting moves the headlight beams up to 15 degrees left or right of the straight ahead position when you turn the steering wheel, helping improve your vision of the approaching bend.

**▶ Adaptive brake lights.** ABS brakes can shorten your stopping distance in slippery road conditions, but what about the driver behind you? With Corsa, if the ABS is activated at over 18mph, your brake lights blink at five times a second, warning the following driver that you're emergency braking.

**Double pretensioners.** Front seatbelt pretensioners act on the diagonal shoulder restraint on all models. And on the lap belt too, on Club models and above. So in the event of a collision, they're ready to interact with the front airbags and compensate for lateral seat movement.



**▶ Security.** Every Corsa features an engine deadlock immobiliser and central deadlocking – by remote control on most models – with an internal door locking switch for added reassurance in the event of unwanted attention from outside the car. The Corsa SRi adds a remote control security alarm as standard.



**▶ Security.** Every Corsa features an engine deadlock immobiliser and central deadlocking – by remote control on most models – with an internal door locking switch for added reassurance in the event of unwanted attention from outside the car. The Corsa SRi adds a remote control security alarm as standard.





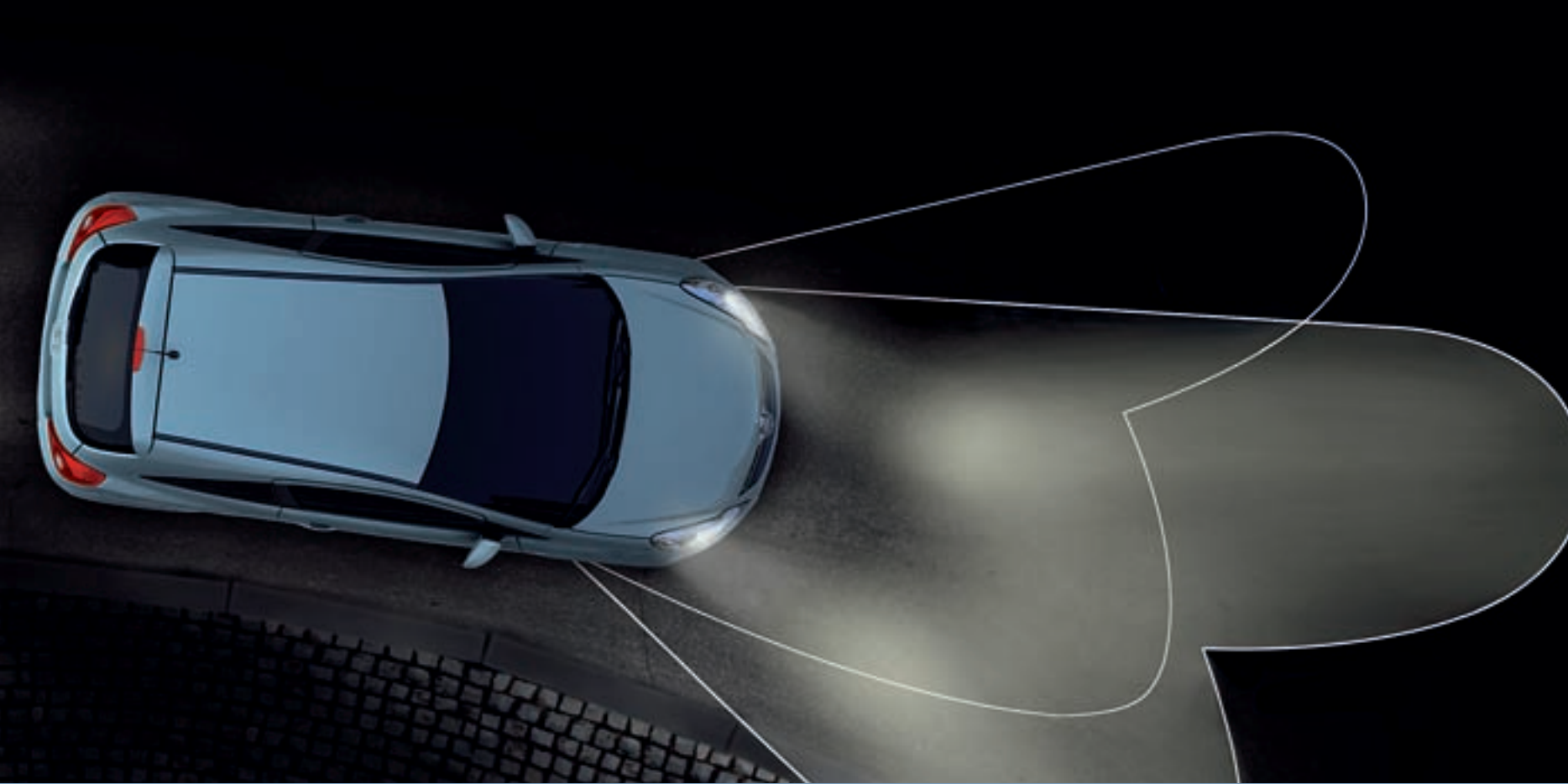

## Intelligent safety

Our life-saving safety features are almost taken for granted on Vauxhall cars nowadays, but it doesn't mean we've stopped inventing new ones. Double front seatbelt pretensioners and adaptive brake lights are just two examples of how Corsa achieves such a high safety rating.

**Door-to-door illumination.** Every Corsa features door-to-door illumination. Just flick the headlight stalk as you exit the car and the dipped headlights and rear lights stay on for 30 seconds – helping you find your way out of an unlit driveway or car park. Some models feature welcome lighting too, switching on the interior light and rear number plate lights when the car is unlocked.



**Infotainment.** If quality sounds are high on your agenda, you won't be disappointed by Corsa. Choose Expression or Life and you get a quality radio/CD player. Select Club, Design, SXi or SRi and you're also treated to MP3 CD format and a new auxiliary-in socket so you can play tracks direct from your personal MP3 player. The optional CD 60 system adds sophisticated satellite navigation. And a mobile phone system\* with Bluetooth® wireless connectivity is also available. Turn to page 50 for more feature information.

\*Please refer to the Vauxhall Car and Accessory Price Guide for a list of phone-specific cradles.



**Rain and light sensors.** Automatic lighting control can switch the car's lights on when it gets dark. Other sensors can switch the wipers on and even dim the rear-view mirror – all automatically. These features are standard on Design and optional as the Sight and Light Pack on SXi and SRi.



**Air-con and ECC.** Air conditioning provides chilled air on hot days, faster demisting on damp days and a more pleasant atmosphere throughout the year. Move up to Electronic Climate Control (ECC) for a more consistent control of the interior temperature.



**Cruise control.** The easy-to-use, twist up/twist down cruise control, available as part of the Plus Pack on Club, Design, SXi and SRi, allows you to maintain a steady speed without keeping your foot on the throttle. So it's more comfortable on long journeys and easier to keep to speed limits too.





▲ **Driving position.** You're going to be spending some quality time in your Corsa. So we've made it easy for you to make sure it's exactly how you want it. The Corsa interior is big on ergonomic efficiency. Which means it's designed around real people, with space to relax and plenty of room for long legs and broad shoulders – front and rear. All the controls are within easy reach so you don't have to take your eyes off the road for more than a moment to adjust the heating or the audio, for example.

Best of all, it's easy to find the perfect seating position with a driver's seat that moves six ways – including height adjustment – on most models. On Club models and above (optional on Life as part of the Plus Pack), you'll find fully adjustable steering too, bringing us right back to what we said earlier about real people and perfect ergonomics.



## Easy life

Corsa is available with some pretty brilliant features so you never have to compromise on what you really want. Like real quality audio and satellite navigation. Your favourite seating position. And added peace of mind. So it's easy to choose a Corsa that fits the way you live perfectly.



## Clever equipment

How do you build a small car that feels like a big one? You give it plenty of space for you and your friends. You make room available for all your kit with clever storage solutions. And you make plenty of smart features available, so every Corsa is exactly the way you want it.



▼▶ **Flex-Fix®.** If your plans change all the time, so can your Corsa. Choose the optional revolutionary Flex-Fix® system and it incorporates an integrated carrier for two bikes, so you don't need a separate roof or rear carrier. Please see additional information below right or page 58 for more technical information.



▲ **Sunroof with interior blind.** Corsa's optional electrically operated sunroof stretches wide across the car for maximum fresh air and blue sky. And if the sun's too strong, you simply wind out the roller blind to reduce glare. Noise is kept to a minimum thanks to an integrated wind deflector.



◀▲▶ Most of the time Flex-Fix® stays hidden behind the rear number plate, but when the need arises, you simply extend it, attach the extra rear lights, fix your bikes to the carrier and off you go. An acoustic warning sounds when the carrier is extended and reverse gear is engaged.



▼ **Translucent controls.** Smart backlight, translucent controls are standard on the audio equipment and, on some models, heating and air conditioning system and window switches. On Design, SXi and SRi, the front and (on 5-door models) rear footwells are gently lit too, for a subtle, welcoming effect.



◀▼ **Clever storage.** Corsa has so many places to keep your belongings. There are drinks holders and storage compartments in the centre console, an underseat storage tray under the front passenger's seat and the front door pockets (and rear side panels on 3-door models) have holders for bottles up to 1.5L.

▲ **Luggage area.** Some Corsa models feature a DualFloor luggage compartment. When the rear seat backs are folded, it provides a long, level, load surface which makes loading that bit easier. And when lowered, it offers a deeper load area.





# C'MON!

## Make a choice

So here's the question. Do you get what you want? Or make do with what you get? We suspect the former. So it's just as well that Corsa comes with a brilliant choice of feature-packed models, petrol and diesel engines, and drop-dead gorgeous colour and trim choices.

**EXPRESSION AND LIFE**

Yet more Vauxhall models that disprove the theory that you only get what you pay for, Corsa Expression and Life come packed with all this essential kit for a super-competitive price.

**Standard features include:**

- Driver's and front passenger's dual-stage airbags
- Anti-lock Braking System (ABS)
- Emergency Brake Assist
- Cornering Brake Control
- Electronic engine deadlock immobiliser
- Stereo radio/CD player
- Speed-sensitive power-assisted steering
- Door-to-door illumination
- Electrically adjustable door mirrors
- Body-colour bumpers
- Central locking (remote control on Life)
- Electrically operated front windows (Life)
- Welcome lighting (Life)

Engine availability	Insurance groups (ABI)	
	20	50
<b>Expression 3-door</b>		
1.0i 12v	1E	1E
<b>Life 3- and 5-door</b>		
1.0i 12v	1E	2E
1.2i 16v	2E	4E
1.2i 16v Easytronic	2E	4E
1.3CDTi 16v (75PS) EcoFlex	3E	6E

*Please note: Insurance groups relate to both the previous 20 group rating and the new 50 group rating.*

*Two-coat pearlescent paint is optional at extra cost.*



**Optional Life Plus Pack**

- Driver's seat height adjuster
- Steering column adjustable for reach and rake (above)



## CLUB

Go on. Treat yourself. Choose Corsa Club for specially co-ordinated interior colour combinations, added versatility and plenty of brilliant features.

### Additional features over and above Life model include:

- Front seat side-impact and full-size curtain airbags
- Stereo radio/CD with MP3 format
- Auxiliary-in socket
- Steering wheel mounted audio controls
- Steering column adjustable for reach and rake
- Driver's seat height adjuster
- 60/40 split-folding rear seat back
- Electrically heated door mirrors
- Chrome-effect interior detailing
- DualFloor luggage compartment
- Body-colour door handles
- 15-inch steel wheels

### Engine availability

### Insurance groups (ABI)

	20	50
--	----	----

3- and 5-door

1.2i 16v	2E	4E
1.2i 16v Easytronic	2E	4E
1.4i 16v	3E	6E
1.4i 16v Automatic	3E	6E
1.3CDTi 16v (75PS) EcoFlex	3E	6E

*Please note: Insurance groups relate to both the previous 20 group rating and the new 50 group rating.*

*Air conditioning, Easytronic transmission and two-coat pearlescent paint are optional at extra cost.*



### Optional Club Plus Pack

- 15-inch five-spoke alloy wheels
- Cruise control (above)
- Front fog lights
- Multi-function trip computer

Club

**DESIGN**

Make no mistake, Corsa Design makes a high quality style statement in every respect. Inside and out, it's a small car loaded with upmarket features.

**Additional features over and above Club model include:**

- Air conditioning
- 16-inch alloy wheels
- Automatic Lighting Control
- Rain-sensitive windscreen wipers
- Front and rear seats with Morrocana side bolsters
- Front fog lights
- Translucent lighting and window controls
- Leather-covered steering wheel
- Sports instruments
- Piano black centre console
- Platinum-coloured seatbelts
- Rear reading light (5-door)
- Front map reading lights

**Engine availability**

**Insurance groups (ABI)  
20 50**

3- and 5-door

1.2i 16v	3E	4E
1.4i 16v	4E	6E
1.4i 16v Automatic	4E	6E
1.3CDTi 16v (90PS)	4E	8E
1.7CDTi 16v (125PS)	6E	13E

*Please note: Insurance groups relate to both the previous 20 group rating and the new 50 group rating.*

*Four-speed automatic transmission and two-coat metallic paint are optional at extra cost.*



**Optional Design Plus Pack**

- Electronic Climate Control
- Cruise control
- Multi-function trip computer
- Graphic Information Display (above)

## SXi

Dynamic handling and responsive performance are certainly good reasons to choose SXi. But so is the ability to stand out and get away in style.

### Additional features over and above Club model include:

- 16-inch alloy wheels
- Sports suspension
- Front fog lights
- Dark-style headlights
- Sports-style front seats
- Translucent lighting and window controls
- Sports instruments
- Matt chrome-effect centre console
- Rear reading light (5-door)
- Front map reading lights
- Leather-covered sports steering wheel
- Chrome-effect exhaust tailpipe
- Progressive rate variable ratio speed-sensitive power steering

Engine availability	Insurance groups (ABI)	
	20	50

3- and 5-door

1.2i 16v	3E	4E
1.4i 16v	4E	6E
1.4i 16v Automatic	4E	6E
1.3CDTi 16v (90PS)	4E	8E

*Please note: Insurance groups relate to both the previous 20 group rating and the new 50 group rating.*

*Air conditioning, Sight and Light Pack, 17-inch twin-spoke alloy wheels and two-coat metallic paint are optional at extra cost.*



### Optional SXi Plus Pack

- Electronic Climate Control
- Cruise control
- Multi-function trip computer
- Graphic Information Display (above)

**SRI**

Corsa SRI is back! Queue here if you appreciate sports styling inside and out, with sharp chassis dynamics and powerful turbocharged engines.

**Additional features over and above SXi model include:**

- 17-inch alloy wheels
- Body-colour sports front lower spoiler, side sills, rear lower skirt and rear spoiler
- Uprated sports suspension (1.6i 16v Turbo)
- ESP-plus with Enhanced Understeering Control (switchable on 1.6i 16v Turbo models)
- Aluminium pedals
- Remote control security alarm system
- Two-tone leather-covered sports steering wheel
- Leather-covered gear knob
- Red seatbelts

**Engine availability**

**Insurance groups (ABI)**  
**20 50**

3- and 5-door

1.6i 16v Turbo	13A	26A
1.7CDTi 16v (125PS)	7E	14E



**Optional SRI Plus Pack**

- Electronic Climate Control
- Cruise control
- Multi-function trip computer
- Graphic Information Display (above)

*Please note: Insurance groups relate to both the previous 20 group rating and the new 50 group rating.*

*Adaptive Forward Lighting, Sight and Light Pack and air conditioning are optional at extra cost.*



◀ **Aluminium pedals.** Standard on Corsa SRI, aluminium pedals add a further sporting accent to the Corsa cockpit. They also feature rubber inserts for additional grip.

▶ **Body styling.** Serious body styling is all part of the new SRI package. Not just this rear skirt, but a front lower spoiler, side sills, a rear roof spoiler, a chrome-effect exhaust tailpipe and 17-inch five-spoke alloy wheels.





SRI

## Options and accessories

Vauxhall options and accessories are all about choice – selecting your new car, then personalising it to suit yourself. There's a choice of factory-fitted options and a huge range of retailer-fit accessories. You can also choose styling products from the VXR range as well as auto design specialist Irmischer International. You'll find further information on the following pages or just ask your Vauxhall retailer for more details.



## VXR Styling

Inspired by the hugely successful VXRacing team, Vauxhall VXR styling products come with all the same experience, knowledge, and passion for style and performance. They put the accent firmly on quality and exclusivity, with a winning edge. And they add flair, personality and excitement to every Corsa model. VXR styling products are available as factory-fit option packs or accessories fitted by your Vauxhall retailer. Please refer to the Vauxhall Car and Accessory Price Guide for availability details of the full Vauxhall VXR styling range.

### ◀ ▼ VXR Styling Pack One.\*

Available on SXi models the VXR Styling Pack consists of a front lower spoiler, side sills, rear roof spoiler and rear skirt. These items are also available separately as retailer-fit accessories. Vehicle illustrated additionally features optional 17-inch alloy wheels.



## Irmscher Styling

Developed in conjunction with auto design specialists Irmscher International, Corsa styling accessories perfectly complement the vehicle's lines, as well as being manufactured to the same exacting standards as the car itself. For availability details of these features – please refer to the Vauxhall Car and Accessory Price Guide.



▲ Irmscher Styling Pack\*. Treat your Corsa to the Irmscher Styling Pack which consists of body colour front lower spoiler, side sills, rear hood spoiler and rear bumper sports insert. Vehicle illustrated also features cross hatch grille with aluminium upper and laser-etched 'Irmscher' logo and 17-inch Sport Star alloy wheels.

\*Not available on models fitted with the optional Flex-Fix® system.



### ▲ Irmscher rear hood spoiler.

Typical of the quality and attention to detail that goes into every Irmscher styling product, the Corsa rear hood spoiler is aerodynamically optimised and adds real visual impact. It's available for both three- and five-door models.



▲ Irmscher alloy wheels. They're the perfect way to personalise your Corsa. With a huge range to choose from (style illustrated is Stila), and sizes from 14 to 17 inches, you're sure to find one to suit your style and budget. And don't forget to ask about our accessory wheel locking kits too.

Available individually or in special packs at great prices, Corsa options can make life better in so many ways. Alloy wheels, infotainment upgrades, air conditioning, a sunroof – there's a huge range to choose from. Simply make your choice when you order your new car and it'll be fitted at the factory for you. You'll find further information on availability in the Equipment section. Or you can ask your Vauxhall retailer.

*Club model illustrated features glass sunroof, Plus Pack and two-coat pearlescent paint optional at extra cost.*





**▶ Rear parking distance sensor.** This clever early warning system helps safeguard your car. When reverse gear is selected, the system beeps as you reverse close to an obstruction, rising to a continuous tone when the object is approximately 300mm away.



**▼ Bluetooth®.** With the optional mobile phone system, your phone interfaces with the infotainment unit, for operation via the steering wheel controls and fascia display. Bluetooth® wireless connectivity with voice activation is included. Does not include phone or cradle.

## OPTIONS AND OPTION PACKS

Corsa options are available individually or in special option packs at great prices. The Equipment section has more details.

### INDIVIDUAL OPTIONS INCLUDE:

- Flex-Fix® integrated carrier system
- Air conditioning
- Halogen adaptive forward lighting
- Electronic Stability Programme-plus (ESP-plus)
- ISOFIX system for front passenger seat

**◀ Satellite navigation.** Fast becoming the 'must have' option for people on the move, this CD-ROM based Sat Nav system guides you to your destination, with clearly spoken directions and directional pictograms of the route. It can also point out accident black spots, schools and points of interest.



**◀ Sunroof with interior blind.** Optional on all models except Expression and Life, Corsa's electrically operated sunroof has a manually operated roller blind to reduce glare, and twin-chamber insulation to reduce noise when it's shut. An integrated wind deflector reduces wind noise, too.



**◀ Sight and Light Pack.**

- Automatic lighting control
- Rain-sensitive windscreen wipers
- Electro-chromatic anti-dazzle rear-view mirror



**◀ ▶ Alloy wheels.** Nothing sets your car apart like a stunning set of Vauxhall alloys. Check out the 15-inch alloy wheel, available as part of the Plus Pack on Club models (above) and the larger 17-inch size for Design and SXi (left).



Vauxhall accessories are the right choice for your Corsa. Whatever you're into, there's certain to be a Vauxhall accessory with your name on it, all fitted by trained Vauxhall professionals. We've only featured a small selection of what's available here. The Vauxhall Car Accessory Brochure and Car and Accessory Price Guide give further details or check out our website at [www.vauxhall-accessories.com](http://www.vauxhall-accessories.com)



◀ **Cargo Liner.** Don't let your car's load area take a beating. Protect it with this semi-rigid moulded plastic liner. Designed with lipped sides for a snug fit, it provides maximum protection, yet is easily removed for cleaning.



▲ **Rear parking distance sensors.** Helping reduce the risk of bumps and scrapes, this two-sensor, retailer-fit system beeps as you reverse close to an obstruction, changing to a continuous tone when the object is approximately 300mm away.



◀ **Base carrier.** The Vauxhall roof rack system begins with this base carrier. It comprises of two T-track bars which support a wide range of attachments. Each carrier is supplied with locks for security.

▶ **Child seats.** Vauxhall offers a range of child seats, ergonomically styled for comfort and safety. The Baby-Safe (for babies from birth to 13kg), and Kid (15-36kg) seats are fixed with a standard lap and diagonal seatbelt, while the Duo ISOFIX (9-18kg) can also be attached using the ISOFIX child seat restraint fittings, which are standard on the outer rear seats of all Corsa models. The rigid ISOFIX anchoring mechanism virtually eliminates the dangers of incorrect child seat installation. Corsa is also compatible with Vauxhall's new Top Tether system, designed to stop the top of ISOFIX child seats moving forward in a frontal collision. For further information, please ask for a copy of the Vauxhall Accessories Child Seat brochure available from your Vauxhall retailer.



## VAUXHALL ACCESSORY PACKS

Vauxhall accessory packs bring together a selection of essential accessories at great prices, helping you to protect your car and equipping you for roadside emergencies.



◀ **Sunshades.** Look cool and stay cool with our removable rear and rear side window sunshades. Provides effective protection against the sun's glare while adding a definite style accent to your car. Excellent view-through properties for enhanced safety.



◀ ▶ **Protection Pack.**

- Velour mats
- Mudflaps
- Cargo liner

▶ **Side-loading bicycle carrier.** The perfect solution for easy loading and unloading, this innovative carrier has a swinging support bar which ensures the bike clears the side and roof of the car. A gas-assisted strut helps take the weight of the bike. Two carriers can be fitted to one base carrier.



▶ **Travel Pack.**

- First aid kit
- Warning triangle
- Hi-visibility vest



# CORSA VXR

**This is extra-sensory stimulation. Cars with soul and power to make you feel alive, electrified and inspired. A range of driver-focused, performance machines for the road, born on the track.**







- > Unique VXR body styling
- > 192PS 1.6i 16v Turbo
- > VXR Recaro shell-backed sports seats
- > 17-inch Y-design alloy wheels
- > 18-inch V-spoke alloy wheels with anthracite inner, 225/35 R 18 ultra-low profile tyres illustrated far right (optional at extra cost)



DISCOVER 6.8<sup>SEC</sup>  
0-60MPH

VXR takes all the experience, knowledge and passion gained from over 110 BTCC wins and crystallises it into a range of high performance road cars. Clinching the 2007 Dunlop MSA British Touring Car Championship (BTCC) driver and manufacturer honours in the final race of the season, Vauxhall became the most successful manufacturer in the modern era, accumulating seven Drivers Championships, seven Manufacturers Championships and four team titles along the way.

*For more information on the Corsa VXR please ask your Vauxhall retailer for a copy of the latest VXR range brochure.*

“IT’S FAST, IT’S MEAN AND IT’S READY TO TAKE THE HOT HATCH MARKET BY STORM.”

*AUTO EXPRESS – JANUARY 2007*





## CORSA VXR.

Whichever way you look at it, Corsa VXR doesn't hang around. The lightweight 1.6 litre turbo puts out 192PS and the software controlled overboost increases max torque to 260+Nm for safer overtaking. No worries in the chassis department either. With lowered sports suspension, bigger brakes and Electronic Stability Programme (ESP) with traction control – it's all designed for rapid, safe progress.

This season's 'must have' colour? Take your pick from a brilliant range of Corsa shades. Plenty to choose from. All coupled with a great new cloth trim line-up.

*Due to the limitations of the printing process the colours reproduced may vary slightly from the actual paint colour or trim material. As a result they should be used as a guide only. Your Vauxhall retailer has a comprehensive display of all our paint samples and trim swatches.*

*\*Optional at extra cost.*



▶ Flame Red – solid



▶ Glacier White – solid



▶ Royal Blue – solid



▶ Sunny Melon – solid





▶ Metro Blue – metallic\*



▶ Green Spirit – metallic\*

*Restricted availability, see page 43.*



▶ Silver Lightning – metallic\*



▶ Ultra Blue – pearlescent\*



▶ Star Silver – metallic\*



▶ Black Sapphire – pearlescent\*



▶ Lancelot – metallic\*



▶ Air Blue – pearlescent\*



Interior trims

▼ Punch, Charcoal



▼ Cable, Indian Red



▼ Cable, Charcoal

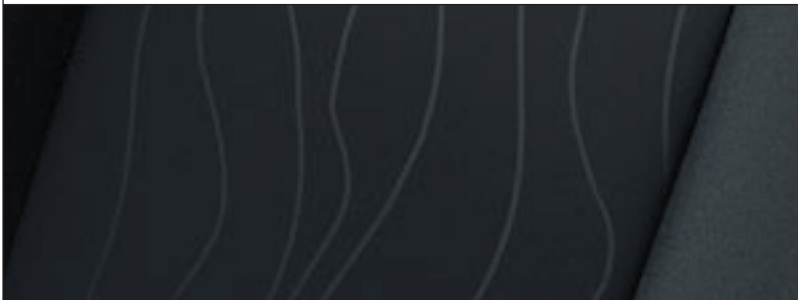

▼ Cable, Asia Blue



Exterior colours

Model, trim name and trim colour

	Expression Punch cloth	Life Punch cloth	Club Cable cloth	Design Fuse cloth/Morrocana	SXi Fuse cloth	SRi Oxygen cloth
<b>Solid</b>						
Flame Red	Charcoal	Charcoal	Charcoal	Charcoal	Red	Charcoal/Red
Glacier White	Charcoal	Charcoal	Charcoal or Red	Charcoal	Red	Charcoal/Red
Royal Blue	Charcoal	Charcoal	Charcoal or Blue	Charcoal	-	-
Sunny Melon	Charcoal	Charcoal	Charcoal	Charcoal	-	-
<b>Two-coat metallic*</b>						
Metro Blue	-	Charcoal	Charcoal or Blue	Charcoal	Red	-
Silver Lightning	-	Charcoal	Charcoal or Blue	Charcoal	Red	Charcoal/Red
Star Silver	-	Charcoal	Charcoal or Red	Charcoal	Red	Charcoal/Red
Lancelot	-	Charcoal	Charcoal or Blue	Charcoal	-	-
Green Spirit**	-	Charcoal	Charcoal	-	-	-
<b>Two-coat pearlescent*</b>						
Ultra Blue	-	Charcoal	Charcoal	Charcoal	-	-
Black Sapphire	-	Charcoal	Charcoal or Red	Charcoal	Red	Charcoal/Red
Air Blue	-	Charcoal	Charcoal or Blue	Charcoal	-	-

\* = Optional at extra cost. \*\* = Only available on 1.3CDTi 16v (75PS) EcoFlex models. - = Exterior colour listed is not available on this model.

▼ Fuse/Morrocana, Charcoal

▼ Fuse, Garnet Red

▼ Oxygen, Red

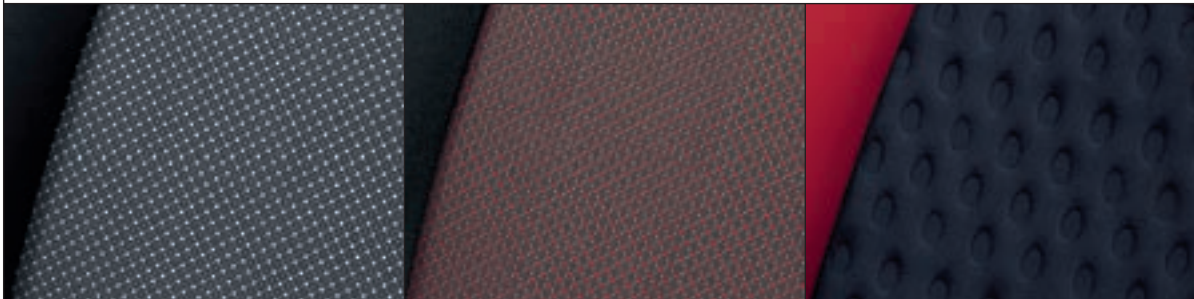

## Contents

### Equipment

Safety Security	44
Heating and ventilation Facia, instruments and controls Seating	45
Additional interior features Mechanical	46
Exterior and convenience features Exterior protection and styling	47
Exterior lighting	48
Wheels and tyres	49
Audio, navigation and communication	50
Option packs	52
<b>Technical data</b>	
Engines	54
Performance, fuel economy and emissions	55
Weights and towing data	56
Vauxhall Assistance and warranties, transmissions, steering, suspension and brakes	57
Exterior dimensions Luggage capacities	58
Features explained	59

## Safety

**Standard features** • Driver's dual-stage airbag • Front passenger's dual-stage airbag • Pedal release system – Reduces potential injury to the driver's legs and feet during a severe frontal impact • Laminated windscreen • Reinforced passenger safety cell • Side-impact protection beams • Fuel tank located ahead of rear axle

• Child-proof locks on rear doors • ISOFIX child seat restraint system for outer rear seats incorporating top tether – Secures specially designed ISOFIX child safety seats to the vehicle itself, virtually eliminating the dangers that can result from improper installation (does not include child seat) • Deactivation switch for front passenger's airbag

• Anti-lock Braking System (ABS) with Electronic Brakeforce Distribution • Straight Line Stability control – see **D1** on page 59 • Cornering Brake Control – see **D2** on page 59 • Emergency Brake Assist – see **D3** on page 59 • Adaptive Brake Lights • Drag Torque Control – Helps maintain stability when suddenly lifting off the accelerator

• Height-adjustable front seat head restraints • Height-adjustable front seatbelts • Pyrotechnic front body-lock seatbelt pretensioner system – Tightens the diagonal belt during the early stages of a frontal impact • Driver's and front passenger's seatbelt force limiters – Reduces potential upper body injuries during a frontal impact • Adjustable outer rear seat head restraints • Height-adjustable centre rear seat head restraint (five-door models only) • Three inertia-reel lap and diagonal rear seatbelts • Anti-submarining ramps in all seats – Help prevent occupants sliding underneath the lap belt during a collision • Driver's seatbelt unfastened audible warning

<b>Additional features</b>	Exp.	Life	Club	Design	SXi	SRI
Front seat side-impact airbags	□	□	●	●	●	●
Full-size curtain airbags	□	□	●	●	●	●
Pyrotechnic front lap belt pretensioner system	□	□	●	●	●	●
Electronic park/brake pedal safety interlock (on automatic transmission models)			●	●	●	
Electronic Stability Programme-plus (ESP-plus) with traction control – see <b>D4</b> on page 59. Switchable on 1.6i 16v Turbo SRI models only	○	○	○	○	○	●
ISOFIX child seat restraint system for front passenger's seat (does not include child seat)		○	○	○	○	○

## Security

**Standard features** • Electronic theft protection for audio equipment • Electronic engine deadlock immobiliser • 'Key left in ignition' audible warning • Visible Vehicle Identification Number (VIN) • Door-to-door illumination

<b>Additional features</b>	Exp.	Life	Club	Design	SXi	SRI
Central locking (doors, tailgate, fuel flap)	●					
Remote control central locking (doors, tailgate, fuel flap) with security deadlocks		●	●	●	●	●
Remote control security alarm system						●

## Heating and ventilation

**Standard features** • Side window demist vents and four adjustable heating and ventilation outlets • Air blend heater with four-speed fan and illuminated controls • Interior pollen filter

<b>Additional features</b>	Exp.	Life	Club	Design	SXi	SRi
Interior odour-reducing activated charcoal filter	●	● <sup>1</sup>	● <sup>1</sup>		● <sup>1</sup>	● <sup>1</sup>
Air conditioning (includes air recirculation facility)		○	○	●	○	○
Electronic climate control incorporating air conditioning (includes graphic information display)				□	□	□

## Facia, instruments and controls

**Standard features** • Multi-function display panel showing time, date, audio information and outside air temperature (with ice warning function) • Digital clock with automatic RDS time adjustment • Adjustable speed limit audible warning – Allows the driver to set the speed above which an alarm sounds • Trip odometer • Rev counter • Electronically controlled fuel gauge • Low fuel level warning light • Headlight/brake light bulb failure warning light • Service-due indicator • Handbrake-on warning light • Instrument panel light dimmer • Glovebox with lid • Electrical accessory socket

<b>Additional features</b>	Exp.	Life	Club	Design	SXi	SRi
Steering column adjustable for reach and rake		□	●	●	●	●
Leather-covered steering wheel				●		
Leather-covered sports steering wheel					●	
Two-tone leather-covered sports steering wheel						●
Leather-covered gear knob						●
Sports instruments				●	●	●
Multi-function trip computer			□	□	□	□
Cruise control			□	□	□	□

## Seating

**Standard features** • Reclining front seats • Front passenger's underseat storage tray (deleted if optional glass sunroof is specified) • Adjustable rear seat backrest • Easy-entry front seats with memory function (three-door models only)

<b>Additional features</b>	Exp.	Life	Club	Design	SXi	SRi
Driver's seat height adjuster		□	●	●	●	●
Front passenger's seat height adjuster <sup>2</sup>			○	○	○	○
Sports-style front seats					●	●
One-piece folding rear seat	●	●				
60/40 split-folding rear seat back			●	●	●	●



Electronic climate control.



Steering column adjustable for reach and rake.

- = Standard equipment
- = Optional at extra cost.
- = Only available as part of an extra-cost option pack (see page 52 for details).
- Exp. = Expression.

- 1 = Activated charcoal filter is deleted if optional air conditioning is specified.
- 2 = Fitted in conjunction with optional glass sunroof. Not available separately.



Stowable luggage compartment cover.



Front door pockets.



Chrome-effect trim on instrument surrounds.

## Additional interior features

**Standard features** • Front door pockets • Rear door pockets (five-door models only) • Rear bottle holders (three-door models only) • Chrome-effect door handles • Drinks holder and coin holders in centre console • Front tiltable driver's and passenger's assist handles • Two rear tiltable passenger assist handles (five-door models only) • Dipping rear-view mirror • Twin sunvisors with vanity mirror and sliding cover • Two rear coat hooks • Luggage compartment cover • Stowage facility for luggage compartment cover behind rear seats • Illuminated luggage area • Load restraint lashing eyes • Interior tailgate handles • Interior courtesy light operated by door switches • Chrome-effect handbrake button • Translucent lighting for radio control

<b>Additional features</b>	Exp.	Life	Club	Design	SXi	SRi
Chrome-effect trim on instrument surrounds			●	●	●	●
Chrome-effect gear knob trim (manual models only)			●	●	●	●
Satin stone-effect centre console	●	●				
Satin stone-effect centre console and steering wheel inlays			● <sup>3</sup>			
Piano black centre console and steering wheel inlays			● <sup>4</sup>	●		
Matt chrome-effect centre console and steering wheel inlays					●	●
Platinum-coloured seatbelts				●		
Red seatbelts						●
Rear reading light (five-door models only)				●	●	●
Front map reading lights			○ <sup>2</sup>	●	●	●
Translucent lighting for heating, window and lighting controls				●	●	●
Ambient footwell lighting (front only on three-door models)				●	●	●
Electro-chromatic anti-dazzle rear-view mirror				●	□	□
DualFloor luggage compartment			●	●	●	●
Aluminium pedals						●

## Mechanical

**Standard features** • Front-wheel drive • Five-speed manual gearbox • Speed-sensitive electric power-assisted steering • Gas-pressure dampers • Front anti-roll bar

<b>Additional features</b>	Exp.	Life	Club	Design	SXi	SRi
Six-speed manual gearbox (1.3CDTi 16v (90PS), 1.6i 16v Turbo, 1.7CDTi 16v models)				●	●	●
Four-speed automatic transmission with Winter driving mode (1.4i 16v models only)			○	○	○	
Easytronic five-speed transmission with sequential manual gearshift or automatic mode (1.2i 16v models only)		○	○			
Progressive-rate variable ratio power-assisted steering				○ <sup>5</sup>	●	●
Sports suspension with lower ride height (1.7CDTi 16v only on SRi models)				○ <sup>5</sup>	●	●
Upated sports suspension with lower ride height (1.6i 16v Turbo only)						●

## Exterior and convenience features

**Standard features** • Heated rear window • Intermittent rear window wash/wipe • Two-speed windscreen wipers with variable intermittent wipe • Tinted glass • Manually foldable door mirrors

<b>Additional features</b>	Exp.	Life	Club	Design	SXi	SRi
Rain-sensitive windscreen wipers				●	□	□
Electrically operated front windows with safety autoreverse and one-touch facility		●	●	●	●	●
Twin electrically adjustable door mirrors (wide-angle on driver's side)	●	●				
Twin electrically adjustable/heated door mirrors (wide-angle on driver's side)			●	●	●	●
Folding key		●	●	●	●	●
Two-tone horn					●	●
Electrically operated sliding glass sunroof with interior blind <sup>6</sup>			○	○	○	○
Rear parking distance sensors <sup>7</sup>			○	○	○	○
Flex-Fix <sup>®</sup> integrated carrier system (includes two-bicycle carrier attachment) <sup>8</sup> – see page 58 for important Flex-Fix <sup>®</sup> and bicycle dimensions information			○	○	○	
Two-coat metallic or pearlescent paint		○	○	○	○	○

## Exterior protection and styling

<b>Features</b>	Exp.	Life	Club	Design	SXi	SRi
Body-colour bumpers	●	●	●	●	●	●
Body-colour rear spoiler					□	●
Body-colour front lower spoiler/side sills/rear lower skirt					□	●
Dark-style headlights					●	●
Part body-colour door mirrors	●	●	●			
Full body-colour door mirrors				●	●	●
Body-colour door handles			●	●	●	●
Body-colour tailgate handle	●	●	●	●	●	●
Black foil on B-pillars (not with optional Black Sapphire two-coat pearlescent paint)				●	●	●
Chrome-effect exhaust tailpipe extension					●	●



Six-speed manual gearbox.



Folding key.

- = Standard equipment.
- = Optional at extra cost.
- = Only available as part of an extra-cost option pack (see page 52 for details).
- Exp. = Expression.
- 2 = Fitted in conjunction with optional glass sunroof. Not available separately.
- 3 = Only on models fitted with Charcoal or Asia Blue trim.
- 4 = Only on models fitted with Indian Red trim.
- 5 = Fitted in conjunction with optional 17-inch alloy wheels. Not available separately.
- 6 = Also includes front passenger's seat height adjuster and front map reading lights. Deletes front passenger's underseat storage tray.
- 7 = Not available in conjunction with Flex-Fix<sup>®</sup> system.
- 8 = Not available in conjunction with rear parking distance sensors or VXR Styling Pack One. The spare wheel is replaced by an emergency tyre inflation kit.



Adaptive Forward Lighting.



Front fog lights.



Automatic Lighting Control.

## Exterior lighting

**Standard features** • Lights-on audible warning • Electric headlight beam levelling • High-level LED centre brake light • Rear fog light • Dual Ellipsoidal halogen headlights

Additional features	Exp.	Life	Club	Design	SXi	SRi
Welcome lighting		●	●	●	●	●
Adaptive Forward Lighting				○	○	○
Automatic Lighting Control				●	□	□
Front fog lights			□	●	●	●

### Adaptive Forward Lighting – halogen

Optional at extra cost on Design, SXi and SRi. Adaptive Forward Lighting is a sophisticated lighting system that 'allows you to see around corners'! Corsa is one of the first cars in its class to offer such technology. *Autocar* magazine describes it as a 'must-have' feature. There are two main functions:

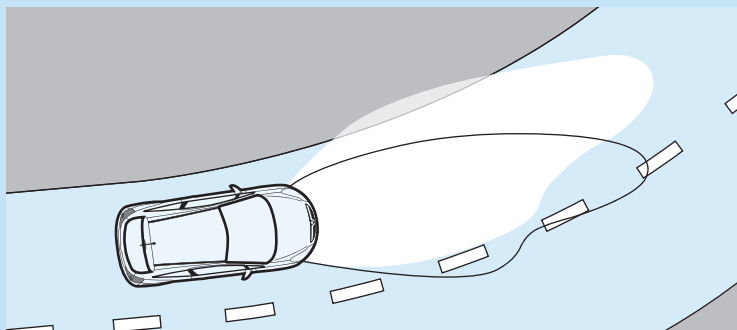

#### Curving light

Speed-dependent, the system is activated by movements of the steering wheel and allows the headlight beam to move up to 15 degrees left or right of the straight ahead position. This ensures that the main headlight beams are always aimed in the direction you're about to go – and not necessarily the direction the front of the car is already pointing in!

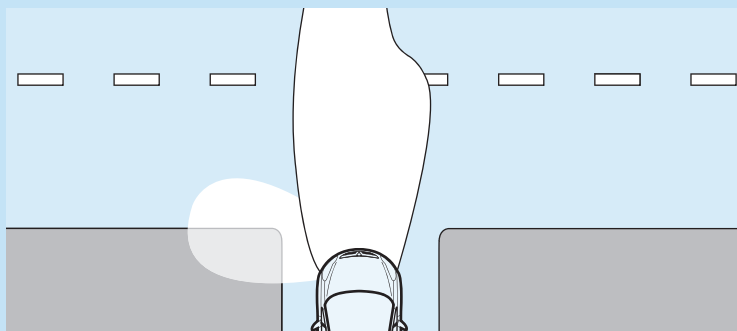

#### Cornering light

When turning into a junction or rounding a tight corner, the cornering light projects an additional beam of light at approximately 90 degrees to the direction of travel, giving the headlights a helpful 'wide angle' effect without detracting from the regular beam. It's activated in one of two ways: simply detecting the application of steering lock at slow speeds and it also reacts to the application of the indicators as you approach a junction.



## Wheels and tyres

Features	Exp.	Life	Club	Design	SXi	SRi
Flush wheel covers	●	●	●			
14-inch steel wheels with 185/70 R 14 low profile tyres <b>W1</b>	●	●				
15-inch steel wheels (14-inch spare) with 185/65 R 15 low profile tyres <b>W2</b>			●			
15-inch alloy wheels (14-inch steel spare) with locking bolts and 185/65 R 15 low profile tyres <b>W3</b>			□			
16-inch seven-spoke alloy wheels (15-inch steel spare) with locking bolts and 195/55 R 16 ultra-low profile tyres <b>W4</b>				● <sup>9</sup>		
16-inch twin-spoke alloy wheels (15-inch steel spare) with locking bolts and 195/55 R 16 ultra-low profile tyres <b>W5</b>					●	
17-inch five-spoke alloy wheels (emergency tyre repair kit in lieu of spare wheel) with locking bolts and 215/45 R 17 ultra-low profile tyres <b>W6</b>						●
17-inch twin-spoke alloy wheels (16-inch steel spare) with locking bolts and 215/45 R 17 ultra-low profile tyres <b>W7</b>				○ <sup>10</sup>	○ <sup>11</sup>	

● = Standard equipment.  
 ○ = Optional at extra cost.  
 □ = Only available as part of an extra-cost option pack (see page 52 for details).  
 Exp. = Expression.

<sup>9</sup> = 1.7CDTi 16v models feature five-bolt wheel attachment, all others are four-bolt.  
<sup>10</sup> = Also includes sports suspension with lower ride height and progressive-rate variable ratio power-assisted steering. 1.7CDTi 16v models feature five-bolt wheel attachment, all others are four-bolt.  
<sup>11</sup> = Optional alloy wheel features four-bolt attachment, not five-bolt as illustrated below.



Standard Expression/Life wheel cover.

Standard Club wheel cover.

Optional Club Plus Pack alloy wheel.



Standard Design alloy wheel.

Standard SXi alloy wheel.

Standard SRi alloy wheel.

Optional Design/SXi alloy wheel.



CD 30 stereo radio/CD player.



CD 60 stereo radio/CD with MP3 format/satellite navigation.

## Audio, navigation and communication

Features	Exp.	Life	Club	Design	SXi	SRI
<b>CD 30 stereo radio/CD player</b> • AM/FM stereo radio with 36 station presets • RDS with Traffic Programme • CD player • Remote display • 17 watts per channel output • 4 speakers	●	●				
<b>CD 30 MP3 stereo radio/CD player with MP3 format</b> • AM/FM stereo radio with 36 station presets • RDS with Traffic Programme • CD player with MP3 format • Auxiliary-in socket • Remote display • 20 watts per channel output • 7 speakers			●	●	●	●
<b>CD 60 stereo radio/CD player with MP3/satellite navigation</b> • AM/FM stereo radio with 40 station presets • RDS with Traffic Programme • CD player with MP3 format • Satellite navigation system • Auxiliary-in socket • Remote monochromatic graphic information display • 20 watts per channel output • 7 speakers			○	○	○	○
Mobile phone system with Bluetooth® (does not include phone or phone-specific cradle) and graphic information display			○	○	○	○
Steering wheel mounted audio controls			●	●	●	●



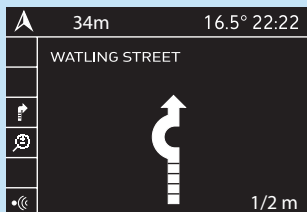

### Satellite navigation

The CD 60 stereo radio/CD with MP3 format/navigation unit uses the international network of GPS (Global Positioning System) satellites (originally developed by the US military) linked to a comprehensive CD-ROM mapping system to determine your precise location and guide you to your chosen destination virtually anywhere in mainland Britain. The system is very simple to operate, using a range of menu-driven options which are easily accessed via the steering wheel mounted audio controls.

The audible direction guidance prompt gives details of road numbers and motorway junction numbers, while you can also plan your route to avoid toll roads, if required. In addition route guidance instructions in the form of directional arrows are shown on the centrally mounted monochromatic graphic information display.

The CD 60 also features Traffic Message Channel (TMC), a specific application of RDS used for broadcasting real-time traffic information, delivered either visually or verbally. TMC can also offer dynamic route guidance – alerting the driver to a problem on the planned route and calculating an alternative route to avoid the incident.

The CD-ROM supplied with the system covers all major link roads and streets in towns and cities across mainland Britain. Discs are updated twice a year and are available at extra cost by subscription. Additional discs can be purchased for all major European countries, which means that making a cross-European trip can now be as simple as changing a CD.

### Auxiliary-in socket

The auxiliary-in socket allows you to connect your portable MP3 music player directly into the car's audio system. All you need is your music player and a suitable connecting lead and you can listen to all your favourite tunes through your car's speaker system. Using your MP3 music player in the car couldn't be easier – use it to select the music, as you would normally do, while controlling the volume via the car's regular volume controls.

### Mobile phone system with Bluetooth®

Vauxhall's factory-fit dual-band mobile phone system has been considerably enhanced. Now fully integrated into the audio and communication system, it also features voice control and will connect wirelessly to phones with Bluetooth® technology.

All the required information is displayed on the multi-function display when a mobile phone is in use, while the menus are easily navigated by either the steering wheel audio controls or the multi-function button on the radio. Certain functions can also be controlled by voice activation.

Mounted on the centre console, the phone system base unit can be fitted with phone-specific cradles (available as accessories) for many different mobile phones. A list of compatible cradles is featured in the Vauxhall Car and Accessory Price Guide.



Mobile phone system with Bluetooth®.



Mobile phone system main menu.

- = Standard equipment.
- = Optional at extra cost.
- Exp. = Expression.

12 = Not available in conjunction with Flex-Fix® integrated carrier system. The spare wheel is replaced by an emergency tyre inflation kit.

## Option packs

	Exp.	Life	Club	Design	SXi	SRi
<b>VXR Styling Pack One</b> ● Body-colour front lower spoiler/side sills/ rear lower skirt/rear roof spoiler					○ <sup>12</sup>	●
<b>Sight and Light Pack</b> ● Rain-sensitive windscreen wipers ● Automatic Lighting Control ● Electro-chromatic anti-dazzle rear-view mirror				●	○	○
<b>Protection Pack</b> ● Front seat side-impact airbags ● Full-size curtain airbags ● Pyrotechnic front lap belt pretensioner system	○	○	●	●	●	●
<b>Life Plus Pack</b> ● Driver's seat height adjuster ● Steering column adjustable for reach and rake		○	●	●	●	●
<b>Club Plus Pack</b> ● 15-inch alloy wheels (14-inch steel spare) with locking bolts ● Front fog lights ● Cruise control ● Multi-function trip computer			○			
<b>Design/SXi/SRi Plus Pack</b> ● Electronic climate control incorporating air conditioning ● Cruise control ● Graphic information display ● Multi-function trip computer				○	○	○

### VXR Styling Pack One<sup>12</sup>

- Body-colour front lower spoiler/side sills/ rear lower skirt/rear roof spoiler



### Sight and Light Pack

- Rain-sensitive windscreen wipers
- Automatic Lighting Control
- Electro-chromatic anti-dazzle rear-view mirror



### Protection Pack

- Front seat side-impact airbags
- Full-size curtain airbags
- Pyrotechnic front lap belt pretensioner system

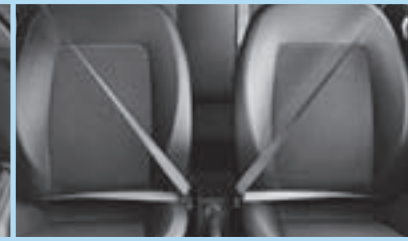

### Life Plus Pack

- Driver's seat height adjuster
- Steering column adjustable for reach and rake

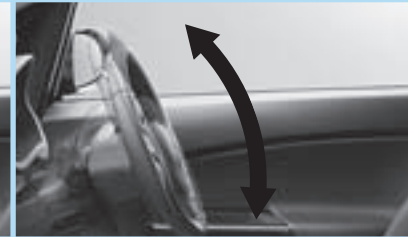
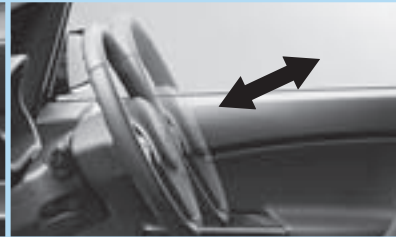

### Club Plus Pack

- 15-inch alloy wheels (14-inch steel spare) with locking bolts
- Cruise control
- Front fog lights
- Multi-function trip computer



### Design/SXi/SRi Plus Pack

- Electronic climate control incorporating air conditioning
- Cruise control
- Graphic information display
- Multi-function trip computer





Twinport petrol engines.



Common rail turbo diesel engines.

## Petrol engines

	1.0i 12v Twinport ECOTEC-Compact	1.2i 16v Twinport ECOTEC-4	1.4i 16v Twinport ECOTEC-4	1.6i 16v Turbo ECOTEC-4
Capacity	998cc	1229cc	1364cc	1598cc
Maximum power	60PS (44kW) @ 5600rpm	80PS (59kW) @ 5600rpm	90PS (66kW) @ 5600rpm	150PS (110kW) @ 5000rpm
Maximum torque	88Nm (65 lb.ft.) @ 3800rpm	110Nm (81 lb.ft.) @ 4000rpm	125Nm (92 lb.ft.) @ 4000rpm	210Nm (155 lb.ft.) @ 1850-5000rpm
Configuration	3 cylinders, 4 valves per cylinder, double overhead camshafts	4 cylinders, 4 valves per cylinder, double overhead camshafts		
Fuel/induction system	Naturally aspirated with vacuum-controlled Twinport inlet ports. Multi-point sequential electronic fuel injection			Turbocharger with intercooler. Multi-point sequential electronic fuel injection
Service interval	20,000 miles or 1 year (whichever occurs sooner)			

### Benefit in kind company car taxation – 2007/08 tax year\*

Manual models exc. SXi	15%	15%	16%	24%
Manual SXi models	-	16%	16%	-
Easytronic models	-	15%	-	-
Automatic 3-door models	-	-	19%	-
Automatic 5-door models	-	-	20%	-

## Diesel engines

	1.3CDTi 16v (75PS) ECOTEC-4	1.3CDTi 16v (90PS) ECOTEC-4	1.7CDTi 16v ECOTEC-4
Capacity	1248cc	1248cc	1686cc
Maximum power	75PS (55kW) @ 4000rpm	90PS (66kW) @ 4000rpm	125PS (92kW) @ 4000rpm
Maximum torque	170Nm (126 lb.ft.) @ 1750-2500rpm	200Nm (147 lb.ft.) @ 1750-2500rpm	280Nm (206 lb.ft.) @ 2300rpm
Configuration	4 cylinders, 4 valves per cylinder, double overhead camshafts		
Fuel/induction system	Turbocharger with intercooler. Common rail fuel injection	Variable geometry turbocharger with intercooler. Common rail fuel injection	
Service interval	20,000 miles or 1 year (whichever occurs sooner)		

### Benefit in kind company car taxation – 2007/08 tax year\*

All models	18%	18%	18%
------------	-----	-----	-----

\* = For details of 2008/09 tax year benefit in kind company car taxation rates please refer to the latest Vauxhall Car and Accessory Price Guide.

## Performance, fuel economy and emissions

Model	Performance (manufacturer's figures)			Fuel economy mpg (litres/100km)			CO <sub>2</sub> emissions (g/km)
	Maximum speed (mph)	Acceleration (secs) 0-60mph	30-50mph (4th gear)	Urban driving	Extra-urban driving	Combined figure	
<i>Manual</i>							
1.0i 12v	93	17.0	12.2	38.7 (7.3)	61.4 (4.6)	50.4 (5.6)	134
1.2i 16v excluding SXi	104	13.0	12.0	36.7 (7.7)	60.1 (4.7)	48.7 (5.8)	139
1.2i 16v SXi	104	13.0	9.1	35.3 (8.0)	56.5 (5.0)	46.3 (6.1)	146
1.4i 16v	107	11.8	8.2	34.9 (8.1)	55.4 (5.1)	45.6 (6.2)	149
1.6i 16v Turbo	130	7.6	4.8	26.9 (10.5)	44.1 (6.4)	35.8 (7.9)	189
1.3CDTi 16v (75PS)	101	13.6	8.1	49.6 (5.7)	74.3 (3.8)	62.8 (4.5)	119
1.3CDTi 16v (90PS)	107	11.9	7.6	45.6 (6.2)	70.6 (4.0)	58.9 (4.8)	127
1.7CDTi 16v 3-door	121	9.3	6.7	45.6 (6.2)	70.6 (4.0)	58.9 (4.8)	130
1.7CDTi 16v 5-door	121	9.3	6.7	44.8 (6.3)	68.9 (4.1)	57.6 (4.9)	132
<i>Easytronic</i>							
1.2i 16v	104	14.4	-	37.2 (7.6)	61.4 (4.6)	49.6 (5.7)	137
<i>Automatic</i>							
1.4i 16v 3-door	103	13.8	-	32.5 (8.7)	49.6 (5.7)	41.5 (6.8)	163
1.4i 16v 5-door	103	13.8	-	32.1 (8.8)	48.7 (5.8)	40.9 (6.9)	166

The fuel consumption figures shown comply with EC directive 1999/100 to provide a realistic indication of fuel consumption by taking into account everyday driving conditions, such as cold starts, acceleration and braking. These figures take account of the vehicles kerbweight, ascertained in accordance with the above regulation. **Important:** the results given relate to the particular car tested. Driving style, road and traffic conditions, vehicle mileage and standard of maintenance may also affect fuel consumption; therefore the results do not express or imply any guarantee of fuel consumption attainable.

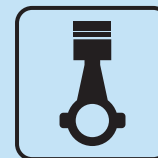

### 150PS

1.6i 16v Turbo engine gives punchy performance



### 74.3mpg

1.3CDTi 16v (75PS) engine is compact and economical

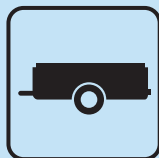

**1300kg**  
Maximum  
towing weight



**520kg**  
Maximum  
carrying capacity

## Weights and towing data (kg)

	Kerbweight (Gross vehicle weight)				Maximum towing weights Trailer with brakes (without brakes)			
	3-door		5-door		3-door		5-door	
1.0i 12v Expression	1025	(1545)	–	–	500	(450)	–	–
1.0i 12v Life	1025	(1545)	1070	(1565)	500	(450)	500	(500)
1.2i 16v Life (exc. Easytronic)	1055	(1555)	1085	(1585)	850	(450)	850	(500)
1.2i 16v Life Easytronic	1055	(1555)	1085	(1585)	800	(450)	800	(500)
1.2i 16v Club (exc. Easytronic)	1070	(1555)	1092	(1585)	850	(450)	850	(500)
1.2i 16v Club Easytronic	1070	(1555)	1092	(1585)	800	(450)	800	(500)
1.2i 16v Design	1096	(1575)	1117	(1605)	850	(450)	850	(500)
1.2i 16v SXi	1069	(1555)	1099	(1585)	850	(450)	850	(500)
1.4i 16v Club	1080	(1565)	1095	(1595)	1000	(500)	1000	(500)
1.4i 16v Club automatic	1105	(1590)	1120	(1620)	1000	(500)	1000	(500)
1.4i 16v Design	1106	(1585)	1120	(1615)	1000	(500)	1000	(500)
1.4i 16v Design automatic	1131	(1610)	1145	(1640)	1000	(500)	1000	(500)
1.4i 16v SXi	1079	(1565)	1102	(1595)	1000	(500)	1000	(500)
1.4i 16v SXi automatic	1104	(1590)	1127	(1620)	1000	(500)	1000	(500)
1.6i 16v Turbo SRi	1194	(1680)	1219	(1705)	–	–	–	–
1.3CDTi 16v (75PS) Life	1130	(1645)	1160	(1675)	1000	(500)	1000	(500)
1.3CDTi 16v (75PS) Club	1145	(1645)	1167	(1675)	1000	(500)	1000	(500)
1.3CDTi 16v (90PS) Design	1201	(1695)	1222	(1725)	1200	(500)	1200	(500)
1.3CDTi 16v (90PS) SXi	1174	(1675)	1204	(1705)	1200	(500)	1200	(500)
1.7CDTi 16v Design	1244	(1750)	1277	(1780)	1300	(500)	1300	(500)
1.7CDTi 16v SRi	1217	(1730)	1259	(1760)	–	–	–	–

**Please note:** For Life, Club, SXi and SRi models fitted with optional air conditioning 20kg must be added to both kerbweight and gross vehicle weight. **Gross vehicle weight** is the total permissible weight of the vehicle including passengers and their luggage. To determine total carrying capacity, which includes the weight of the driver, deduct kerbweight from gross vehicle weight. The **maximum roof rack loading** should not exceed a total of 75kg. The **maximum towing weights** are based on the ability of the car – with two occupants of 75kg each – to restart on a 12% gradient, which is approximately 1 in 8.3, at sea level. At altitudes above 1500 metres, the engine output may drop with a corresponding reduction in towing capability. Any extra weight, such as luggage or additional passengers, should be deducted from the maximum towing weight. With a trailer fully loaded, **maximum noseweight** should not exceed 55kg. Always fit Vauxhall towing attachments and accessories available from your Vauxhall retailer. They are designed specifically for Vauxhall models and carry a 12-month guarantee.



## Vauxhall Assistance and warranties\*

- A one-year unlimited mileage manufacturer's warranty
- Second and third year no-fee customer option warranty up to 60,000 miles (from first registration)
- Vauxhall Assistance for 12 months from first registration
- Six years' body panel anti-perforation warranty

\* = Warranty is only available on vehicles sourced from Vauxhall Motors Ltd. Terms and conditions apply – please see your Vauxhall retailer for details.

## Optional transmissions

### Five-speed Easytronic transmission:

Available at extra cost on 1.2i 16v Life and Club models. Easytronic transmission is a five-speed manual gearbox with a fully automatic mode. In manual mode, you simply push the lever forward or back to shift gears up or down sequentially. The fascia display tells you what gear you're in – 1 to 5, N for Neutral or A for Auto. Switch to fully automatic mode and it has many of the features of a regular automatic including a kickdown function. There's no clutch pedal so you can drive it on an automatic-only driving licence. Easytronic also comes with a winter mode, which selects second gear for standing starts in slippery conditions.

### Four-speed automatic transmission:

Optional at extra cost on 1.4i 16v models only. Electronically controlled, with Winter driving mode. Fluid drive with torque converter and lock-up on third and fourth ratios eliminating wasteful slip. Electronic park/brake pedal safety interlock. Neutral control fuel-saving feature. Transmission oil cooler integral with engine coolant radiator.

## Steering

- Rack and pinion
- Electric power-assisted steering standard on all models – variable rate on diesel models – progressive variable rate on SXi/SRi models, and on Design models fitted with optional 17-inch alloy wheels
- Turning circle (kerb-to-kerb): All models except Design with optional 17-inch alloy wheels and SXi/SRi – 10.10m (33.2ft). Design with optional 17-inch alloy wheels and SXi/SRi – 11.10m (36.4ft)

## Suspension

**Front:** Independent. MacPherson struts with gas-pressure damper cartridge and coil springs. Anti-roll bar.

**Rear:** Compound crank with progressive-rate mini-block coil springs and gas-pressure dampers.

- Suspension uprated and lowered by 20mm on SXi and SRi models, and on Design models fitted with optional 17-inch alloy wheels

## Brakes

- Anti-lock Braking System (ABS)
- Electronic Brakeforce Distribution
- Emergency Brake Assist
- Cornering Brake Control
- Straight Line Stability control
- Dual circuit, diagonally split, dual rate servo-assisted system
- Low brake fluid level warning light

### 1.0i 12v

Front discs: 257mm diameter

Rear drums: 203mm diameter

### 1.2i 16v (exc. Easytronic and SXi)

Front discs: 257mm diameter

Rear drums: 203mm diameter

### 1.2i 16v (Easytronic and SXi)

Front ventilated discs: 257mm diameter

Rear drums: 203mm diameter

### 1.4i 16v/1.3CDTi 16v (75PS)

Front ventilated discs: 257mm diameter

Rear drums: 228mm diameter

### 1.6i 16v Turbo

Front ventilated discs: 308mm diameter

Rear discs: 264mm diameter

### 1.3CDTi 16v (90PS)

Front ventilated discs: 284mm diameter

Rear drums: 228mm diameter

### 1.7CDTi 16v

Front ventilated discs: 278mm diameter

Rear discs: 264mm diameter

## Body

- Aerodynamic drag co-efficient: Cd 0.33

## Fuel tank capacity

- 45 litres (9.9 gallons)



Five-speed Easytronic transmission.



MacPherson strut front suspension.



Compound crank rear suspension.

Exterior dimensions millimetres (inches)

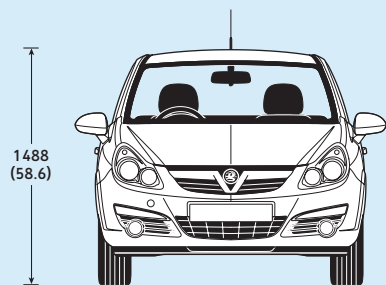

1713 (67.4)  
excluding door mirrors  
1944 (76.5)  
including door mirrors

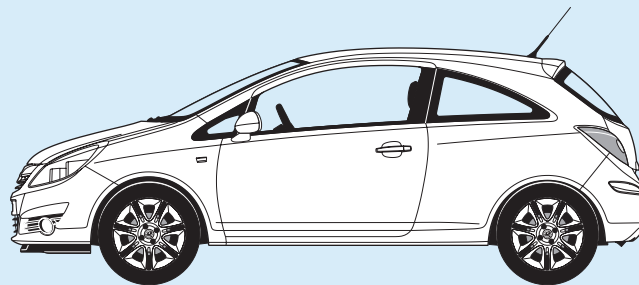

869 (34.2) 2511 (98.9) 619 (24.3)  
3999 (157.4)

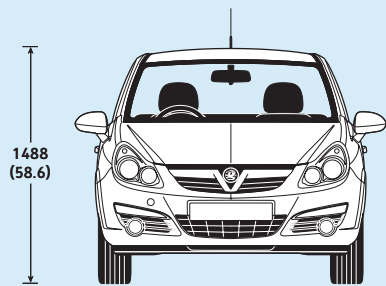

1737 (68.4)  
excluding door mirrors  
1944 (76.5)  
including door mirrors

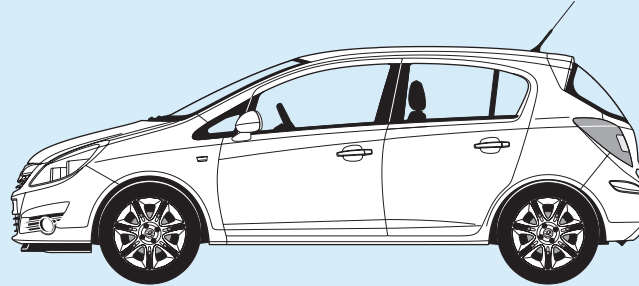

869 (34.2) 2511 (98.9) 619 (24.3)  
3999 (157.4)

Luggage capacities (ECIE method)

3-door	litres	cu.ft
Rear seat up*	285	10.0
Rear seat down (to glassline)	690	24.4
Rear seat down (to roof)	1050	37.1
<b>5-door</b>		
Rear seat up*	285	10.0
Rear seat down (to glassline)	700	24.7
Rear seat down (to roof)	1100	38.8

\* = DualFloor in lowest position.

Luggage compartment dimensions

3-door	mm	inches
Maximum length (seats up)	703	27.7
Maximum length**	1348	53.1
Maximum width	969	38.1
Maximum height	839	33.0
<b>5-door</b>		
Maximum length (seats up)	703	27.7
Maximum length**	1348	53.1
Maximum width	969	38.1
Maximum height	872	34.3

\*\* = Behind front seats.

Flex-Fix® key dimensions

	mm	inches
Maximum circumference around rim and tyre of bicycle	225	8.9
Maximum crank arm width	52	2.0
Maximum crank arm depth	25	1.0
Maximum crank arm length		no limit

## Features explained

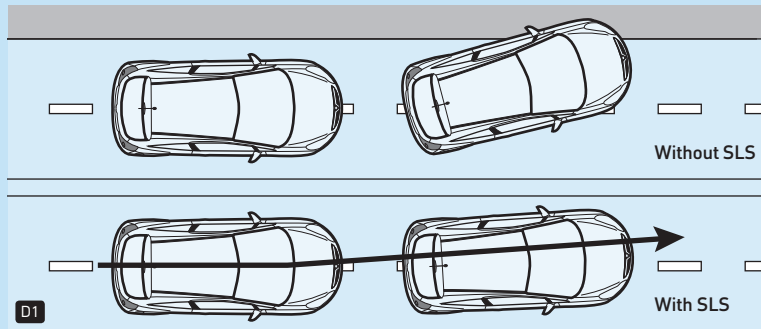

### D1. Straight Line Stability control (SLS)

Optimises directional stability when braking, particularly on roads with varying levels of grip on either side of the car – or those with a pronounced 'crown'. It does this by monitoring the steering angle and comparing this to the rotational speeds of the wheels.

By reducing brake pressure on the front and rear wheels on the appropriate side, it restores the direction of travel to the 'straight-ahead' position.

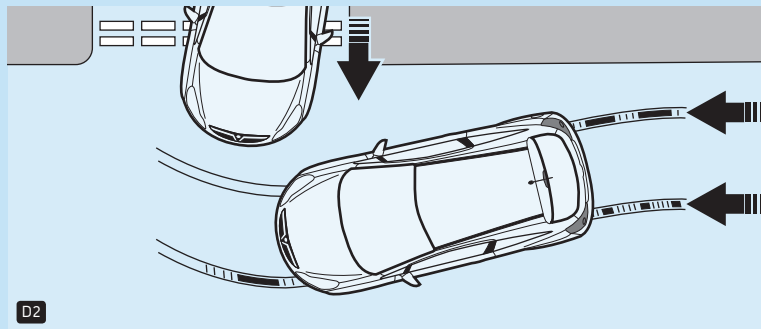

### D2. Cornering Brake Control

Makes the car easier to control in extreme situations, especially when braking sharply on a bend. Particularly effective when carrying out emergency manoeuvres. The system works by sensing the different rotational speeds of the individual road wheels and co-ordinating the level of braking pressure applied to each wheel.

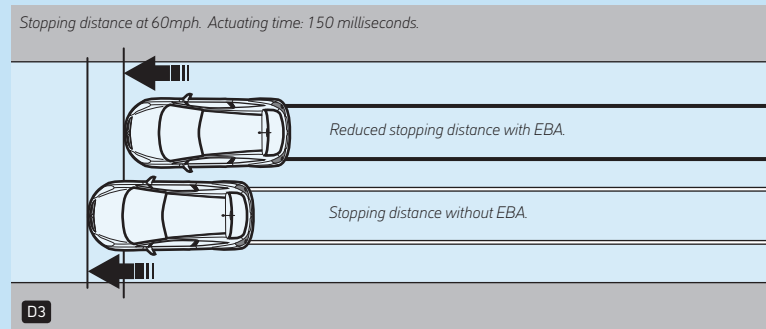

### D3. Emergency Brake Assist (EBA)

Emergency brake assist detects the urgency with which the brake pedal is pressed and rapidly increases the pressure to the maximum the system can provide, shortening stopping distances. It also enhances pedal feel.

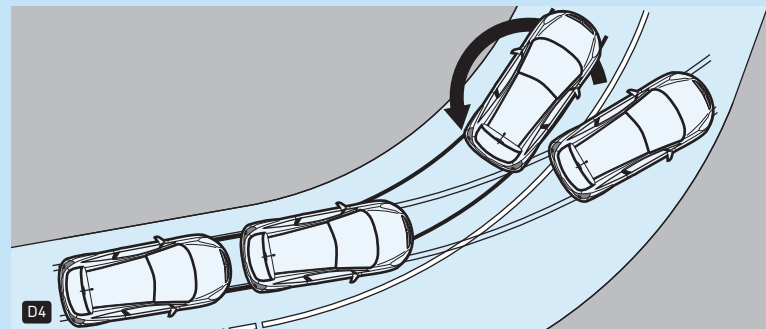

### D4. Electronic Stability Programme-plus (ESP-plus) with Enhanced Understeering Control

The system works in conjunction with the car's traction control set-up, sensing when the vehicle is about to slide on a bend and applying corrective braking to the appropriate wheel or wheels, correcting the slide and helping you regain control more rapidly (with conventional ESP systems the braking force is applied at only one wheel). On 1.6i 16v Turbo SRi models it can be switched off via a button on the fascia.

# Trust Vauxhall

## Protecting the environment

Vauxhall's commitment to the environment is demonstrated by our products' many environmental awards, won both through the use of more recycled materials and by becoming cleaner and more efficient. For information on Vauxhall's efforts to achieve an environmentally sustainable future, see [www.vauxhall.co.uk/recycling](http://www.vauxhall.co.uk/recycling)

## Fleet Customer Services

Our dedicated support services for fleet managers includes factory demonstrators, a three-day test drive programme and information on whole life costs, company car taxation and finance. For further information please call **0870 010 0651**.

## Buying your car

GMAC offers one of the most comprehensive and competitive ranges of financing plans in the UK. Contact your local Vauxhall retailer for details or call the GMAC customer service centre on **0845 712 3444**.



When you have finished with this brochure please recycle it

## Sureguard protection

Sureguard Assistance offers the benefits of Vauxhall Assistance for three years from first registration, while Sureguard Warranty also provides a parts and labour warranty for high-mileage or long-term owners. For details contact your local Vauxhall retailer or call **0870 752 7020**.

## Specialist Mobility advice

Motability accredited Vauxhall retailers can provide special mobility help and advice. Blue badge holders are entitled to very favourable discounts on new vehicles. Contact your local Motability accredited Vauxhall retailer or **Freefone 0800 731 5267**.

## Servicing and maintenance

The best way to maximise the performance and reliability of your Vauxhall is to have all routine servicing and maintenance carried out at one of around 400 Vauxhall retailers. To find your nearest retailer call **0845 600 1500**.

## In the event of an accident...

Vauxhall Accident Support helps keep you mobile following an accident. Benefits include scene-of-accident advice, message service, assistance with claims and vehicle recovery. For further details call **0800 010 304**.

## Vauxhall Insurance

Available for new and used Vauxhalls, a Vauxhall Insurance policy offers a unique package designed specifically for Vauxhall drivers. For a highly competitive quotation, call **0870 024 0240** or visit our website at [www.vauxhall.co.uk](http://www.vauxhall.co.uk)

## For more information...

For a brochure on any Vauxhall model (up to a maximum of three per caller) or location of your nearest Vauxhall retailer please **Lo-call 0845 600 1500**.

Alternatively, details can be found on our website at [www.vauxhall.co.uk](http://www.vauxhall.co.uk)



- Save up to **£2000\*** on a new Vauxhall with The GM Card
- **100 Rebate Points worth £100** when you use The GM Card for the first time
- Rebate Point saving is on top of any discount or offer negotiated with the Retailer
- Earn **3 Rebate Points (£3)** for every **£100** you spend

**Typical 14.9% APR variable**

To apply call **0845 746 2777** or visit [www.gmcard.co.uk](http://www.gmcard.co.uk)

The GM Platinum Card is issued by HFC Bank Limited and is available to persons aged 18 years or over and resident in the UK (or 21 and over in the Channel Islands) and is subject to status and conditions. Written quotations are available upon request from The GM Platinum Card, PO Box 3615, Birmingham B3 2RU. The typical APR quoted is the rate for new customers. \*Rebate Points are earned on purchases using The GM Platinum Card. Rebate Points are not earned on Balance Transfers or Cash Advances. You earn money off a new Vauxhall/Saab by accumulating Rebate Points under the Rebate Points Programme. Vauxhall Motors Ltd is solely responsible for the operation of the Rebate Points Programme, which is subject to the Rebate Points Programme Rules. You can redeem up to 2500 Rebate Points subject to the Model Line Maximum which will vary in amount in relation to different Vauxhall/Saab vehicle model lines and unlimited Partner Points. Rebate Points and unlimited Partner Points are redeemable as discounts on a new Vauxhall/Saab vehicle and must be redeemed four years from the issue date. Rebate Points may not be redeemed by Motability Contract Hire customers. The GM Card is a trading name and style of both HFC Bank Limited and Vauxhall Motors Ltd. HFC Bank registered in England No. 1117305. Registered Office: North Street, Winkfield, Windsor, Berkshire SL4 4TD is authorised and regulated by the Financial Services Authority. **Member HSBC** Group HFC Bank Limited is not a member of the same group of companies as Vauxhall Motors Ltd, Saab GB Limited or GMAC (UK) plc. Vauxhall Motors Ltd. Registered Office: Griffin House, Osborne Road, Luton, Bedfordshire LU1 3YT. Registered in England number 135767. - CN6/0987.

Every effort has been made to ensure that the contents of this publication were accurate and up-to-date at the time of going to press (January 2008). Vauxhall vehicles are equipped with components manufactured by various General Motors operating units and outside suppliers. The Company reserves the right to alter specifications and withdraw products from sale without notice. Any such alterations will be notified to Vauxhall retailers at the earliest opportunity; please consult your local retailer for the latest information. The specifications detailed within this brochure are not necessarily applicable to alternative models such as Special Editions. Details of any such models will be contained in specific literature or found on the Vauxhall website. Please note that Vauxhall retailers are not the agents of Vauxhall Motors Limited and are not authorised to bind the Company by any specific or implied undertaking or representation. It is advisable to ensure that your motor insurance policy provides adequate cover for additional fitted options and accessories. As part of Vauxhall's policy of environmental care, this brochure is printed on paper manufactured using Elemental Chlorine Free pulps from specially farmed, sustainable timber resources. All rights reserved. No part of this publication may be reproduced in any form or by any means, without the prior written permission of Vauxhall Motors Limited.

