

Corsavan

2011 Models Edition 1



The Wheels of Business. Helping you deliver.

Whatever your line of business, Vauxhall Commercial Vehicles can help you deliver. With five different models – including the award-winning New Movano – we offer a massive choice of over 230 variants including panel vans, chassis cabs, chassis crew cabs, platform

cabs, tippers, dropsides, box vans and minibuses. We're also committed to keeping your business moving. That means reliable, fuel-efficient vehicles supported by a dedicated network of over 450 retailers offering the expert support and back-up you need.



We build more commercial vehicles at our British production facilities at Ellesmere Port and Luton than any other UK manufacturer. We've also won over 30 industry awards since 2001 – major awards, presented by some of the toughest judges in the business.

Introduce the in-built reassurance of the Vauxhall brand and it's easy to see why Vauxhall Commercial Vehicles really are 'The Wheels of Business'.





06	Loadspace
08	Dynamics and efficiency
10	Corsavan
12	Corsavan Sportive

14	Options and accessories
16	Customer advocacy
18	Equipment and technical data
22	Colour availability



Corsavan. The small van that gives you more.

Small enough for congested city streets, yet big enough to eat up the miles on the open road, Corsavan matches a dynamic chassis with a spacious cabin and high levels of safety and security. The load area is also easy to access, with purpose-built load protection and a class-leading 550kg payload.

On the road, few vans can match Corsavan's low running costs. Our new 75PS 1.3CDTi 16v diesel engine – in particular – matches superb driveability with low emissions and excellent fuel economy, thanks to the introduction of innovative Start/Stop technology.

Inside, the Corsavan cabin is built for long-term driver comfort, with supportive seats and plenty of useful in-cab storage for paperwork, drinks and other essentials.

With a choice of two models and four engines, Corsavan and Corsavan Sportive – the latter complete with body-colour detailing, 15-inch alloy wheels, a 1.3CDTi 16v (95PS) common rail turbo diesel engine and six-speed gearbox – it's clear to see it's the small van that gives you more.

Some of the vehicles shown in this brochure include options and accessories available at extra cost. And not all of the features described are available on every model. So please check the equipment and technical data section for further details. From time to time, we also offer alternative models such as Special Editions which are featured in separate literature or can be found on the Vauxhall website: www.vauxhall.co.uk/vans

Sportive model illustrated.



Loadspace

Corsavan takes its load carrying duties very seriously, with strong attention to detail in areas that really matter. A tall, wide tailgate aperture makes it easy to load. The long, high load area has superb load and occupant protection features. Most of all, it carries an impressive 550kg maximum payload – a figure that puts all its competitors in the shade.

Easy loadability

The Corsavan has never been easier to load. The tall tailgate aperture allows larger items to be loaded. The tailgate itself lifts high (for good headroom) and extends down into the bumper making for a low loading height.

Load protection

A sturdy steel floor and half-height steel bulkhead, tough sidewall half-height panelling and load restraint lashing eyes are all standard. An upper load restraint mesh, fitted rubber floor mat and four-piece load compartment cover are optional for even more load protection.

Loadspace dimensions*	mm	inches
Maximum load floor length	1257	49.5
Maximum load area height	924	36.4
Maximum load area width	1264	49.8
Width between wheel arches	969	38.1
Load sill height (unladen)	691	27.2
Maximum tailgate aperture height	650	25.6
Maximum tailgate aperture width	980	38.6
Loadspace volume	cu.m	cu.ft
Maximum loadspace volume (VDA method)	0.92	32.5

*Please refer to pages 21–23 of the technical data section for more detailed loadspace, weight and towing data.

Features include:

- > 550kg maximum payload
- > Steel load area floor
- > Half-height steel bulkhead
- > Sidewall half-height panelling
- > Load restraint lashing eyes
- > Upper load restraint mesh (optional)
- > Fitted rubber floor mat (optional)
- > Four-piece load compartment cover (optional)



Dynamics and efficiency

Driving comfort, affordability and safety are major considerations for any busy working van driver. So Corsavan's car-like ride and handling help ensure a comfortable and relaxing day at the wheel – especially now with modifications to the spring, damper and anti-roll bar settings providing even more driving comfort.

Corsavan ecoFLEX models with Start/Stop technology

With a smooth and flexible new Euro 5 compliant 1.3CDTi 16v (75PS) turbo diesel engine matched with the latest Start/Stop technology, Corsavan ecoFLEX models have amongst the lowest vehicle CO₂ emissions in the UK.

Start/Stop is a clutch pedal based system which switches the engine off when you stop at the lights or in traffic, then restarts it automatically once the clutch is depressed, saving fuel and reducing emissions even further. The engine stop is indicated by the rev counter needle in the AUTOSTOP position. The system can be deactivated manually simply by pressing the ECO button on the fascia.

1.3CDTi 16v common rail diesel

Sportive models take our 1.3CDTi 16v (95PS) common rail diesel engine matched to a six-speed gearbox. This delivers outstanding performance combined with excellent fuel economy.

1.2i 16v Twinport

The 70PS (115Nm) multi-valve petrol engine uses advanced Twinport

technology for increased performance and fuel economy and meets Euro 5 emission standards. This unit is backed by a five-speed manual gearbox.

Dynamic SAFety Suspension (DSA)

When any vehicle brakes on surfaces with differing levels of grip (eg. gravel or mud versus dry tarmac), there is always the potential for loss of control. Corsavan's DSA suspension helps correct this tendency, making the van safer under 'break away' conditions.

Anti-lock Braking System (ABS)

The latest ABS system with Electronic Brakeforce Distribution (EBD) and Emergency Brake Assist (EBA) can reduce emergency stopping distances even further, particularly on slippery roads and help drivers retain steering control.

Electronic Stability Programme-plus

The optional ESP-plus with Enhanced Understeering Control (EUC) works in conjunction with the vehicle's Traction Control (TC) system to help you maintain control during adverse or emergency conditions. Traction control also stops wheelspin during acceleration.

The Euro 5 compliant engine choices – common rail diesel and multi-valve petrol – are designed to save you money. Anti-lock Braking System (ABS) with Electronic Brakeforce Distribution (EBD) is standard, as is speed-sensitive power-assisted steering, making Corsavan especially easy to manoeuvre and park.



Start/Stop ECO button

By pressing the ECO button, Start/Stop can be enabled and disabled manually. See page 21 for more details.

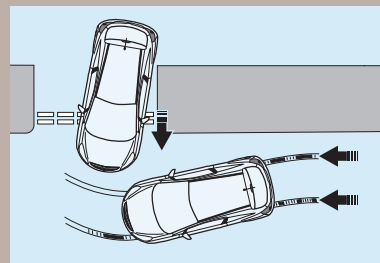

Anti-lock Braking System

ABS with EBD and EBA is fitted as standard to all Corsavan models.

Choice of engines

- > 1.2i 16v (70PS/115Nm) petrol
- > 1.3CDTi 16v (75PS/190Nm) ecoFLEX
- > 1.3CDTi 16v (75PS/190Nm) ecoFLEX Start/Stop
- > 1.3CDTi 16v (95PS/210Nm)*

Features include:

- > Five-speed manual gearbox**
- > Six-speed manual gearbox*
- > Anti-lock Braking System (ABS) with Electronic Brakeforce Distribution (EBD)
- > Electric speed-sensitive power-assisted steering
- > Dynamic SAFety Suspension (DSA)
- > Three-year manufacturer's warranty consisting of a one-year/unlimited mileage warranty plus a second and third year warranty up to 60,000 miles

*Sportive models only.

**Excluding Sportive models.

Corsavan

Known simply as Corsavan, the base model provides a well-equipped and cost-efficient introduction to the model line-up. Drivers can choose between two highly responsive yet economical engines: 75PS 1.3CDTi 16v ecoFLEX common rail turbo diesel (with or without Start/Stop) and 70PS 1.2i 16v Twinport petrol.



Stylish interior

Corsavan models are distinguished by a smart, satin stone-effect centre console. Model illustrated features optional electric windows and accessory Smoker Pack.



In-cab stowage

In-cab stowage features include a passenger's underseat storage tray.



Electrically adjustable door mirrors

Body-coloured and fitted as standard. Electric windows are optional at extra cost.

Corsavan features include:

- › Punch Charcoal cloth seat trim
- › Driver's dual-stage airbag
- › Pyrotechnic body-lock seatbelt pretensioners
- › Anti-lock braking system
- › Emergency brake assist
- › Electronic brakeforce distribution
- › Electronic engine deadlock immobiliser
- › Remote control central locking with security deadlocks
- › Speed-sensitive electric power-assisted steering
- › Five-speed manual gearbox
- › Satin stone-effect centre console
- › CD player/stereo radio (CD 30)
- › Body-coloured electrically adjustable door mirrors

Engines/insurance

> 1.2i 16v	1E
> 1.3CDTi 16v (75PS) ecoFLEX	1E
> 1.3CDTi 16v (75PS) ecoFLEX Start/Stop	1E



Corsavan Sportive

With a host of exterior enhancements that include two-coat metallic paint, body-colour detailing, dark-style headlights and 15-inch alloy wheels – and power provided by a more potent 95PS 1.3CDTi 16v turbo diesel engine – Sportive is an exciting addition to the Corsavan line-up.

Inside, too, Corsavan Sportive adds fresh appeal and driving flair that's bound to excite any small van user. With additional design cues and extra features that include reach and rake adjustable steering, it's perfect for the business that's going places in style.



Sporty interior

Matt chrome-effect centre console and sports instruments add an extra touch of style to the Sportive interior. Model illustrated features accessory Smoker Pack.



Six-speed manual gearbox

Sportive models feature a smooth six-speed manual gearbox as standard.



Reach and rake adjustable steering

Enables operators to achieve the ideal driving position.

Additional features over and above base model include:

- › Sports-style seats with Twist trim
- › Driver's seat height adjuster
- › Steering column adjustable for reach and rake
- › Air conditioning
- › Electrically operated windows
- › Matt chrome-effect centre console
- › Sports instruments
- › Six-speed manual gearbox
- › Electrically adjustable/heated door mirrors
- › Body-coloured door handles
- › Dark-style headlights and tail lights
- › Front fog lights
- › 15-inch alloy wheels
- › Sportive badge
- › Sports chrome exhaust tailpipe
- › Two-coat metallic or pearlescent paint
- › Dark-tinted rear window

Engine/insurance

> 1.3CDTi16v (95PS)

1E



Options

Vauxhall options and accessories are all about choice – selecting your Corsavan then personalising it to suit the way you work. There's a choice of factory-fitted options and a huge range of retailer-fit accessories. You can also choose styling products from the VXR range as well as auto design specialist Irmischer International. For further information please ask your Vauxhall Commercial Vehicle retailer.



Load restraint mesh

Sturdy steel upper load restraint mesh provides added protection against shifting loads.



Load cover/floor mat

Four-piece load compartment cover hides contents from prying eyes whilst a fitted rubber floor mat safeguards the cargo area.



Rear parking distance sensors

Provide an audible warning when an object behind you is detected within a set range when reverse gear is selected.

Individual options include:

- › Satellite navigation/CD player with MP3 format/stereo radio (CD 60)
- › ESP-plus
- › Passenger's airbag
- › Air conditioning*
- › Electrically operated windows*
- › Heated door mirrors*
- › Front fog lights*
- › Rear parking distance sensors
- › Load area rubber floor mat
- › Four-piece load compartment cover
- › Upper load restraint mesh

Option Pack:

Corsavan Plus Pack*

- › Driver's seat height adjuster
- › Steering column adjustable for reach and rake

**Standard on Sportive models.*

Accessories

Vauxhall accessories are the right choice for your Corsavan. The list below is just a small sample of the range available. For a full list, please refer to the Vauxhall Commercial Vehicle Accessories brochure.



Detachable tow bar
Comes complete with 12N electrics and is easily mounted and detached allowing you to take to the road effortlessly.



Rubber floor mats (pair)
To protect your interior from everyday wear and tear. All come with secure fixings and an anti-slip underside.



Base carrier
Our roof rack system begins with this base carrier, comprising two T-track bars. Compatible with a range of attachments.



Irmischer rear hood spoiler
Developed in conjunction with the auto design specialists.



Corsavan VXR Styling Pack
Comprises front lower spoiler, side sills, rear roof spoiler and rear lower skirt.

Accessories include:

- > Headlight protectors
- > Mudflaps
- > Steering wheel security bar
- > Anti-slip mat (915mm x 915mm)
- > MetaSystem alarm
- > Safety Pack (warning triangle, first aid kit and hi-visibility vest)
- > Smoker Pack (cigarette lighter and ashtray)

irmischer

- > Interior styling
- > Exterior body styling
- > Styling Pack
- > Sports silencer
- > Alloy wheels

Vauxhall Commercial Vehicles

The wheels of your business.

Whatever your load, Vauxhall Commercial Vehicles are designed to help you deliver a top quality job. Award-winning models like Corsavan can actively enhance the operating efficiency of your business by delivering outstanding load-carrying potential, low running costs and day-long driver comfort. And whichever Vauxhall Commercial Vehicle you choose, you can also rest assured that Vauxhall's nationwide network of retailers will go the extra mile to meet all your servicing and maintenance needs.

But why take our word for it? Vauxhall's commitment to keeping your business moving is recognised by van operators of all sizes across the length and breadth of the country...



Russell Lelliot, Managing Director, RSL Transport said...
'We've been running Movanos for years. Our two New Movanos save around 4mpg when full, compared to the old models. Which over almost 3,000 miles per week per van, is a big saving!'



Mary Wilson, Owner, Mary Wilson Flowers said...
'As well as handling like cars, our Combos are very fuel efficient – averaging over 45 mpg. That explains why we've always chosen Combo and had 14 in total.'

Marc Daley, Business Director, Amey PLC said...
'Amey are delighted to include the Vauxhall Astravan amongst its fleet. It has proved reliable and has gained user acceptance across a diverse range of operating environments.'





Andrew Cook, Rail Structures Examiner, Amey PLC said...

'The reasons I drive Vivaro? Simple. It's comfortable, the driving position and visibility are great and it's surprisingly compact. This makes it ideal for some of the limited access situations we encounter.'

Mike Sinclair, Senior Property Partner, Aberdeen Considine said...

'We originally selected the Corsavan Sportive for its low running costs and great looks. But it was also important that the vans reflected the professional service that we've worked so hard to deliver to our clients throughout Scotland. Across the fleet of 23 diesel Corsavans, we're achieving an average of up to 65 mpg on some vehicles.'





Front door pockets.



Rev counter.

Safety

Standard features • Driver's dual-stage airbag • Pedal release system – Reduces potential injury to the driver's legs and feet during a severe frontal impact • Laminated windscreen • Side-impact protection beams • Fuel tank located ahead of rear axle • Anti-lock Braking System (ABS) with Electronic Brakeforce Distribution (EBD) – see page 9 • Straight Line Stability control (SLS) – Optimises directional stability when braking • Cornering Brake Control (CBC) – Makes the vehicle easier to control in extreme situations such as braking sharply on a bend • Drag Torque Control (DTC) – Helps maintain stability when suddenly lifting off the accelerator • Emergency Brake Assist (EBA) – Increases brake force applied in emergency braking situations • Adaptive Brake Lights (ABL) – Brake lights flash when ABS is activated, thus warning following vehicles that heavy braking is in progress • Height-adjustable head restraints • Height-adjustable inertia-reel seatbelts • Pyrotechnic body-lock seatbelt pretensioner system – Tightens the diagonal belt during the early stages of a frontal impact • Driver's and passenger's seatbelt force limiters – Reduces potential upper body injuries during a frontal impact • Seatbelt unfastened audible warning • Anti-submarining ramps in seats – Help prevent occupants sliding underneath the lap belt during a collision

Additional features	Corsavan	Sportive
Passenger's dual-stage airbag	<input type="radio"/>	<input type="radio"/>
Electronic Stability Programme-plus (ESP-plus) with traction control – see page 9	<input type="radio"/>	<input type="radio"/>

Security

Standard features • Electronic theft protection for audio equipment • Electronic engine deadlock immobiliser • 'Key left in ignition' audible warning • Visible Vehicle Identification Number (VIN) • Freewheeling door locks • Door-to-door illumination – Keeps the headlights and rear lights on for 30 seconds after the front doors are locked • Remote control central locking (doors, tailgate, fuel flap) with security deadlocks

Facia, instruments and controls

Standard features • Multi-function display panel showing time, date, audio information and outside air temperature (with ice warning function) • Digital clock with automatic RDS time adjustment • Adjustable speed limit audible warning – Allows the driver to set the speed above which an alarm sounds • Trip odometer • Rev counter • Electronically controlled fuel gauge • Low fuel level warning light • Headlight/brake light bulb failure warning light • Service-due indicator • Handbrake-on warning light • Instrument panel light dimmer • Lights-on audible warning • Electric headlight beam levelling • Glovebox with lid

Additional features	Corsavan	Sportive
Steering column adjustable for reach and rake	<input type="checkbox"/>	<input checked="" type="checkbox"/>
Sports instruments		<input checked="" type="checkbox"/>

Audio, communication and navigation

Features	Corsavan	Sportive
CD player/stereo radio (CD 30) • CD player • AM/FM stereo radio with 36 station presets • RDS with Traffic Programme • Remote display • 17 watts per channel output • Four speakers	●	●
Satellite navigation/CD player with MP3 format (CD 60) • Satellite navigation system • CD player with MP3 format • Auxiliary-in socket • AM/FM stereo radio with 40 station presets • RDS with Traffic Programme • Remote monochromatic graphic information display • 20 watts per channel output • Four speakers	○	○
Mobile phone system with Bluetooth® (does not include phone or phone-specific cradle) and graphic information display	○	○

Heating and ventilation

Standard features • Side window demist vents and four adjustable heating and ventilation outlets • Air blend heater with four-speed fan and illuminated controls • Interior pollen filter • Interior odour-reducing activated charcoal filter ¹		
Additional feature	Corsavan	Sportive
Air conditioning (includes air recirculation facility)	○	●

Seating

Standard features • Reclining front seats • Front passenger's underseat storage tray		
Additional features	Corsavan	Sportive
Punch charcoal cloth trim	●	
Twist charcoal cloth trim with red stitching		●
Sports-style seats		●
Driver's seat height adjuster	□	●

Additional interior features

Standard features • Front door pockets • Chrome-effect door handles • Drinks holder and coin holders in centre console • Front tiltable driver's and passenger's assist handles • Dipping rear-view mirror • Interior courtesy light operated by door switches • Chrome-effect handbrake button • Translucent lighting for radio control		
--	--	--

Mechanical

Standard features • Front-wheel drive • Five-speed manual gearbox (1.2i 16v, 1.3CDTi 16v (75PS)) • Six-speed manual gearbox (Sportive) • Speed-sensitive electric power-assisted steering – Provides light steering for parking with enhanced feedback at normal road speeds, without harming fuel economy • Gas-pressure dampers • Front anti-roll bar		
--	--	--



CD player/stereo radio (CD 30).



Driver's seat height adjuster – standard on Sportive.

- = Standard equipment.
- = Optional at extra cost.
- = Only available as part of an extra-cost option pack (see page 20 for details).

¹ = Activated charcoal filter is unavailable on Sportive models and deleted if optional air conditioning is specified.



Front fog lights.



Flush wheel covers.

Load area

Standard features • Glazed tailgate • Half-height steel bulkhead • Loadspace sidewall half-height protection panelling
• Load restraint lashing eyes • Illuminated load area

Additional features	Corsavan	Sportive
Upper load restraint mesh	○	○
Rubber floor mat	○	○
Load compartment cover (four-piece)	○	○

Exterior features

Standard features • Heated rear window • Intermittent rear window wash/wipe • Two-speed windscreen wipers with adjustable intermittent wipe • Tinted glass • Manually foldable door mirrors • High-level LED centre brake light • Rear fog light • Dual Ellipsoidal (DE) halogen headlights • Twin electrically adjustable door mirrors (wide-angle on driver's side) • Body-colour bumpers
• Part body-colour door mirrors • Body-colour tailgate handle

Additional features	Corsavan	Sportive
Electrically operated windows with safety autoreverse and one-touch facility	○	●
Twin electrically heated door mirrors (wide-angle on driver's side)	○	●
Rear parking distance sensors	○	○
Two-coat metallic or pearlescent paint	○	●
Special paint (restrictions apply – please consult your retailer for availability)	○	
Front fog lights	○	●
Dark-style headlights and tail lights		●
Body-colour door handles		●
Dark-tinted rear window		●
Sports exhaust		●

Wheels and tyres

Features	Corsavan	Sportive
Flush wheel covers	●	
14-inch steel wheels with 185/70 R 14 low profile tyres	●	
15-inch alloy wheels with 185/65 R 15 low profile tyres		●
14-inch steel spare wheel	●	●
Tyre inflation kit in lieu of spare wheel	N/C	N/C

Option pack

Plus Pack	Corsavan	Sportive
• Driver's seat height adjuster • Steering column adjustable for reach and rake	○	●

● = Standard equipment.
○ = Optional at extra cost.
N/C = No-cost option.

Engines

	1.2i 16v Twinport ECOTEC-4	1.3CDTi 16v (75PS) ECOTEC-4 (with or without Start/Stop)	1.3CDTi 16v (95PS) ECOTEC-4
Capacity	1229cc	1248cc	1248cc
Maximum power	70PS (51kW) @ 5600rpm	75PS (55kW) @ 4000rpm	95PS (70kW) @ 4000rpm
Maximum torque	115Nm (85 lb.ft.) @ 4000rpm	190Nm (140 lb.ft.) @ 1750-2250rpm	210Nm (155 lb.ft.) @ 1750-2500rpm
Configuration	4 cylinders, 4 valves per cylinder, double overhead camshafts		
Fuel/induction system	Naturally aspirated with vacuum-controlled Twinport inlet ports. Multi-point sequential electronic fuel injection	Turbocharger with intercooler. Common rail fuel injection	Variable geometry turbocharger with intercooler. Common rail fuel injection
Emission compliance	Euro 5		
Service interval	20,000 miles or one-year (whichever occurs sooner)		

Weights and towing data

Model	UK plated weights and kerbweights kg						Payload kg	Towing weights Trailer with brakes (without brakes) kg	Plated Gross Combination Weights (GCW) kg
	Front axle		Rear axle		Total				
	Plated	Kerb	Plated	Kerb	GVW	Kerb			
1.2i 16v	815	656	820	409	1615	1065	550	785 (500)	2400
1.2i 16v (a/c)	835	677	820	408	1635	1085	550	765 (500)	2400
1.3CDTi 16v (75PS)	900	729	820	411	1690	1140	550	1200 (500)	2745
1.3CDTi 16v (75PS) (a/c)	920	750	820	410	1710	1160	550	1200 (500)	2745
1.3CDTi 16v (95PS)	955	783	820	407	1740	1190	550	1200 (500)	2980

a/c = Air conditioning.

Note: Kerbweights for standard vehicles include coolant, oil, 90% full fuel tank and spare wheel. They will vary according to the vehicle specification (including options and accessories) with a corresponding variation in payload. **Payload figures** do not allow for the weight of the driver, or any passengers, which should therefore be deducted from the figures shown and are subject to correct weight distribution. **Gross plated weights** (including axle weights) quoted on the vehicle plate must never be exceeded. **Roof load** should not exceed 100kg including the weight of the roof rack/carrier.

Fuel economy and emissions

Model	Fuel economy mpg (litres/100km)			CO ₂ emissions (g/km)
	Urban driving	Extra-urban driving	Combined figure	
1.2i 16v	40.9 (6.9)	64.2 (4.4)	53.3 (5.3)	124
1.3CDTi 16v (75PS)	53.3 (5.3)	78.5 (3.6)	67.3 (4.2)	112
1.3CDTi 16v (75PS) S/S	58.9 (4.8)	80.7 (3.5)	70.6 (4.0)	105
1.3CDTi 16v (95PS)	52.3 (5.4)	74.3 (3.8)	64.2 (4.4)	115

S/S = Start/Stop.

Fuel consumption and CO₂ emission data complies with the relevant EU regulations. **Important:** the results given relate to the particular vehicle tested; inevitably there are differences between individual vehicles of the same model. Driving style, road and traffic conditions, vehicle mileage and standard of maintenance may also affect fuel consumption.

Start/Stop technology

Corsavan's Start/Stop system offers real benefits by increasing fuel economy and reducing CO₂ emissions, particularly in town. It does this by automatically stopping the engine when you come to a standstill, and then restarting as you prepare to move off. Before automatically stopping the engine a number of system checks are carried out to ensure that it is both safe and practical to do so. To ensure safety, the driver must depress the clutch pedal, shift in to neutral, and then release the clutch pedal. System checks carried out before Auto Stop activates include:

- Start/Stop system is not manually deactivated via the facia button
- Sufficient brake vacuum is available to prevent the car rolling down an incline
- Battery is in good condition and charged
- Outside air temperature and engine temperature are above specified minima
- Self-cleaning function of the diesel particulate filter is not active

If all of these conditions are satisfied then the vehicle will Auto Stop. When you are ready to pull away from standstill, Auto Restart is activated by depressing the clutch pedal. Whilst at a standstill the vehicle is continually monitored. If necessary, the engine will automatically be restarted. Conditions that would initiate an Auto Restart include:

- Low battery level
- Brake vacuum below specified minimum
- Start/Stop system is manually deactivated
- Stationary for 5.5 minutes.

Colour availability

Solid



Glacier White



Flame Red



Cargo Yellow** (special order only)

* = Two-coat metallic and pearlescent colours are available at no extra cost on Sportive models and at extra cost on base models. ** = Not available on Sportive.

Due to the limitations of the printing process the colours reproduced may vary from the actual colour. As a result they should be used as a guide only. All Vauxhall Commercial Vehicle retailers have a comprehensive showroom colour display, with actual exterior paint samples available for inspection.

Special paint options are available on base models. Restrictions apply, please consult your Vauxhall Commercial Vehicle retailer for availability.

Two-coat metallic*



Star Silver



Technical Grey

Two-coat pearlescent*



Black Sapphire



Waterworld

Vauxhall Assistance and warranties*

- All new Corsavans qualify for a three-year vehicle warranty consisting of a one-year/unlimited mileage manufacturer's warranty and a second and third year manufacturer's warranty with a 60,000 miles limitation
- Vauxhall Assistance for 12 months from first registration
- Six years' body panel anti-perforation warranty

* = Warranty is only available on vehicles sourced from General Motors UK Limited. Terms and conditions apply – please see your Vauxhall retailer for details.

Steering

- Rack and pinion
- Electric power-assisted steering standard – variable rate on diesel models
- Maximum turning circle (kerb-to-kerb): – 10.10m (33.1ft)

Suspension

Front: Independent. MacPherson struts with gas-pressure damper cartridge and coil springs. Anti-roll bar.

Rear: Compound crank with progressive-rate mini-block coil springs and gas-pressure dampers.

Brakes

- Anti-lock Braking System (ABS)
- Electronic Brakeforce Distribution (EBD)
- Emergency Brake Assist (EBA)
- Cornering Brake Control (CBC)
- Straight Line Stability control (SLS)
- Dual circuit, diagonally split, dual rate servo-assisted system
- Low brake fluid level warning light

1.2i 16v

Front discs: 257mm diameter
Rear drums: 203mm diameter

1.3CDTi 16v (75PS)

Front ventilated discs: 257mm diameter
Rear drums: 228mm diameter

1.3CDTi 16v (95PS)

Front ventilated discs: 284mm diameter
Rear drums: 228mm diameter

Electrics

Alternator:

70A (100A with air conditioning)

Maintenance-free battery:

1.2i 16v – 40Ah (50Ah with air conditioning)
1.3CDTi 16v – 65Ah

Fuel tank capacity

- 45 litres (9.9 gallons)

Body

- Aerodynamic drag co-efficient: Cd 0.33
- Extensive anti-corrosion protection

Insurance group

All models – Group 1E.

As recommended by the Association of British Insurers.

Dimensions millimetres (inches)

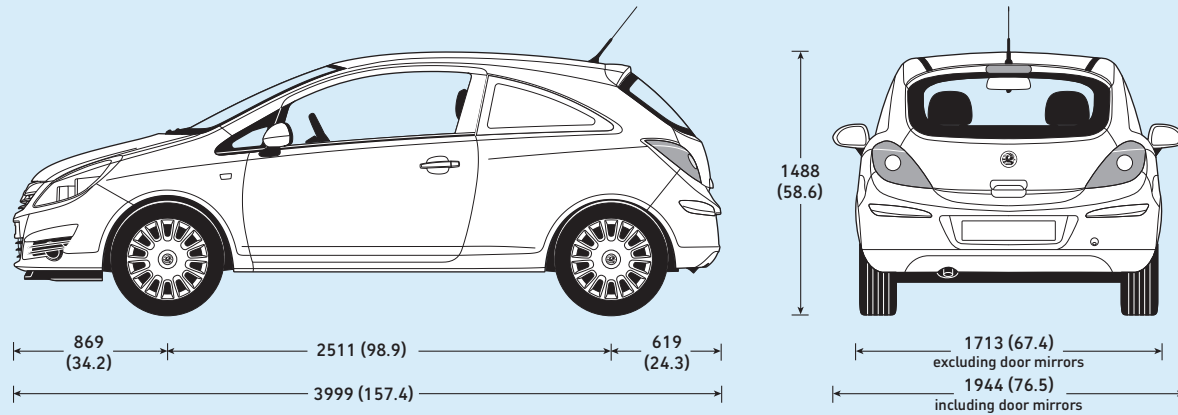

Height shown unladen.

Loadspace dimensions

Maximum load length	mm (inches)
Standard vehicle (A)	1257 (49.5)
Maximum load width	
- At widest point (B)	1264 (49.8)
- Between wheel arches (C)	969 (38.1)
Maximum load height	
Standard vehicle (D)*	924 (36.4)
Rear tailgate	
- Maximum aperture height	650 (25.6)
- Maximum aperture width	980 (38.6)
- Load sill height (unladen)	691 (27.2)

* = Without optional load floor mat

Loadspace volume

VDA method	cu.m (cu.ft)
All models	0.92 (32.5)

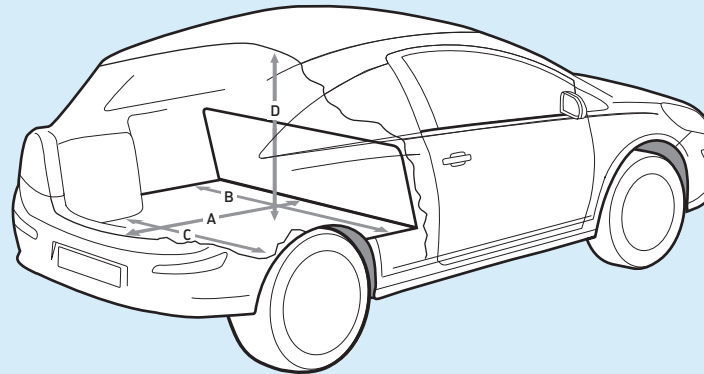

Trust Vauxhall

Protecting the environment

Vauxhall's commitment to the environment is demonstrated by our products' many environmental awards, won both through the use of more recycled materials and by becoming cleaner and more efficient. For information on Vauxhall's efforts to achieve an environmentally sustainable future, see www.vauxhall.co.uk/recycling

Fleet Customer Services

Our dedicated support services for fleet managers includes factory demonstrators and information on whole life costs, company car and van taxation and finance. For further information please call **0870 010 0651**.

Vauxhall Extended Warranty

For complete peace of mind Vauxhall offers an extended warranty that can be purchased on an annual basis following the expiry of the original new vehicle warranty. It covers most mechanical and electrical components. Terms and conditions apply, for further details please contact your local Vauxhall Commercial Vehicle retailer.

Business Lease

Business Lease, from GMAC, offers the versatility of a purchase-based finance plan, while making the most efficient use of tax and cash-flow benefits for VAT-registered business users. It's available for all Vauxhall Commercial Vehicles up to 12 months old and offers highly flexible term lengths, variable deposits and a choice of payment profiles. Ask your retailer for full details.

Business First

Available to business users only, Business First enables you to drive a new vehicle without a large, initial financial outlay. You pay to use the vehicle, not to own it. The vehicle is provided over a predetermined period, and when that period comes to an end the vehicle is returned. Ask your retailer for full details.

Servicing and maintenance

The best way to maximise the performance and reliability of your Vauxhall is to have all routine servicing and maintenance carried out at a Vauxhall Commercial Vehicle retailer. Nationwide there are over 250 light commercial vehicle retailers and a further 195 heavy commercial vehicle retailers.

In the event of an accident...

Vauxhall Accident Support helps keep you mobile following an accident. Benefits include scene-of-accident advice, message service, assistance with claims and vehicle recovery. For further details call **0800 010 304**.

Premier Service Centres

Our Premier Service Centres feature a guaranteed same day repair service (provided the parts are in stock) and an appointment-free service for diagnosis and repairs taking less than 90 minutes. All repairs are carried out within 24 hours of the diagnosis.

For more information...

For a brochure on any Vauxhall model (up to a maximum of three per caller) or location of your nearest retailer, call **0845 600 1500**.

Alternatively, details can be found on our website at: www.vauxhall.co.uk/vans



When you have finished with this brochure please recycle it

Every effort has been made to ensure that the contents of this publication were accurate and up-to-date at the time of going to press (September 2010). Vauxhall vehicles are equipped with components manufactured by various General Motors operating units and outside suppliers. The Company reserves the right to alter specifications and withdraw products from sale without notice. Any such alterations will be notified to Vauxhall retailers at the earliest opportunity, please consult your local retailer for the latest information. The specifications detailed within this brochure are not necessarily applicable to alternative models such as Special Editions. Details of any such models will be contained in specific literature or found on the Vauxhall website. Please note that Vauxhall retailers are not the agents of General Motors UK Limited and are not authorised to bind the Company by any specific or implied undertaking or representation. It is advisable to ensure that your motor insurance policy provides adequate cover for additional fitted options and accessories. Please note accessories shown are for illustrative purposes only. As part of Vauxhall's policy of environmental care, this brochure is printed on paper manufactured using Elemental Chlorine Free pulps from specially farmed, sustainable timber resources. All rights reserved. No part of this publication may be reproduced in any form or by any means, without the prior written permission of General Motors UK Limited.

VM1009012 ©2010 General Motors UK Limited

Published September 2010 (BMB/Graymatter)

General Motors UK Limited, Luton LU1 3YT

COMMERCIAL VEHICLES
The Wheels of Business



VAUXHALL