

ASTRA GTC

2012 Models Edition 1



Proud Sponsor of Home Nations Football



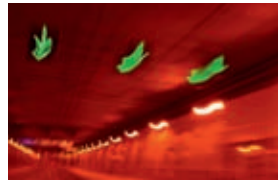
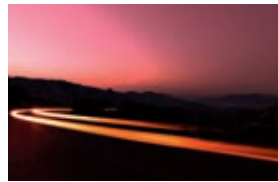

FREE YOUR SPIRIT.

Astra GTC. The designer's dream made reality. With a choice of models, from effortlessly sporty to positively engaging. Brilliantly in tune with your driving emotions, Astra GTC takes Vauxhall's dynamic performance mindset to the limit, with striking details and an unashamedly full-on attitude. Astra GTC: never have three small letters promised so much excitement.

This brochure covers Astra GTC Sport and SRi models only. Some of the images illustrate options and accessories available at extra cost. And not all of the features described are available on both models. So please check in the Equipment section for further details. Due to the limitations of the printing process, the colours reproduced throughout this brochure may vary slightly from the actual paint colour. As a result, they should be used as a guide only. Your Vauxhall Retailer has a comprehensive display of our paint samples.

CONTENTS

ASTRA GTC

Exterior styling	4
Interior styling	10
Driving dynamics	12
Chassis	14
Engines	16
Safety	18
Versatility	20
Infotainment	22
Astra GTC range	24
Wheels and tyres	30
Feature options	32
Colours	34
Trims	36
Accessories	38
Equipment	40
Technical data	46

DRIVE YOUR EMOTIONS.

Bold. Pure. Iconic. Astra GTC puts passion high on the agenda.

Its stunning, coupé-like profile and distinctive, blade-inspired lines speak volumes about Vauxhall's design philosophy. With dramatic styling cues.

And a poised, muscular stance, set off by signature lighting. In short: a clear declaration of sporting intent. And presence to die for.



UNLEASH YOUR PASSION.

Whichever way you look at it, the Astra GTC oozes excitement.

Those ground-hugging lines and powerfully sculpted alloys provide a clear pointer to the car's innate sporting potential – a potential borne out by driver-focused dynamics and precision sports chassis.





MAKE YOUR MARK.

Viewed from any angle, Astra GTC creates a strong impression.

Its bold grille and subtle detailing providing a stylish counterpoint to those unmistakably expressive lines. Parking up or pressing on, those sharp, purposeful looks are guaranteed to attract attention. But then for Astra GTC drivers, that really is half the fun.





Astra GTC

ENERGISE YOUR SENSES.

The Astra GTC's pure and overtly sporting exterior receives a powerful echo throughout the interior's strong lines, with defined textures, unique Astra GTC sports detailing and unashamedly proud contours. Premium quality design cues combine with advanced features to create a sporty yet spacious driving environment guaranteed to invigorate your whole driving experience.





SHARPEN YOUR RESPONSES.

Astra GTC: beautifully balanced, above and below the skin. With a bespoke sports chassis, specifically tuned to the demands of UK roads. Featuring HiPerStrut (High Performance Strut) front suspension and Watt's link rear set-up. The HiPerStrut system improves grip and allows more power to be applied during cornering, significantly reducing torque steer; the Watt's link reduces lateral movement at high speed for a smooth and stable ride.

Optional FlexRide Adds even greater precision to the Astra GTC driving experience. Just the mere touch of a button changes the whole driving dynamic to taut sporting excitement or relaxed long distance cruising. See page 15 for more detail.





➤ EXPLOIT YOUR AGILITY.

Poised, engaging and precise, the Astra GTC chassis establishes the agile, spirited feel that characterises the car as a whole. Better still, the suspension has been carefully tuned to suit the specific demands of UK road surfaces, using specialist input from renowned chassis experts.





Class-leading Sports suspension. Front-wheel drive cars with powerful engines place excessive demands on conventional McPherson strut front suspension systems. Under heavy acceleration – especially in tight bends – front traction is compromised, resulting in torque steer which can affect the car's stability. The compact HiPerStrut (High Performance Strut) system – already seen in Insignia VXR – isolates the steering from the effects of engine torque, boosting steering precision and grip. It also improves handling and enhances ride quality. The compact Watt's Link rear suspension delivers the stability benefits of multi-link systems without their weight and space penalties.



FlexRide chassis settings. With a mere touch of the optional FlexRide button, you can change the Astra GTC's whole driving dynamics – from 'Sport' to 'Tour' and back again. Using Continuous Damping Control (CDC) technology, FlexRide automatically adjusts the dampers for excellent grip. In 'Tour' mode, it chooses the best settings for gentler straight-line driving. Switch to 'Sport' mode and it instantly sharpens the response of the speed-sensitive steering, accelerator and automatic transmission (if fitted). It also changes the colour of the ambient instrument lighting – from a cool white to a more dynamic red effect.

➤ FULFIL YOUR POTENTIAL.

Visually, Astra GTC takes your breath away. Performance-wise, Vauxhall's sensational new arrival carries your strongest emotions in its wake. The potential is limitless.

Astra GTC drivers can choose from four powerful yet efficient engines – all turbocharged and all matched with a slick, six-speed transmission. Free-revving 120PS or 140PS 1.4i 16v VVT Turbo petrol engines. A third petrol unit, the 1.6i 16v VVT Turbo, producing an uncompromising 180PS. Or the highly flexible 2.0CDTi 16v common rail turbo diesel, good for an impressive 165PS.





Start/Stop technology. With power comes responsibility.

So Astra GTC also features Vauxhall's cutting edge Start/Stop fuel saving and emissions reduction technology. The innovative system switches the engine off when you stop at the lights or in traffic, then restarts it automatically once the clutch is depressed. A wide range of in-built safety checks ensures total peace-of-mind in all circumstances (for more information see page 47). It's fitted to all Astra GTC models except the 1.6i 16v Turbo version.



ENGINES

	Wheel size (inches)	Combined fuel economy mpg (litres/100km)	CO ₂ emissions (g/km)	VED (2011/12)*		Benefit in kind tax band** (2011/12 tax year)
				First year	Standard	
Petrol						
1.4i 16v VVT Turbo (120PS)	18/19	47.1 (6.0)	140	£115	£115	18%
1.4i 16v VVT Turbo (120PS)	20	46.3 (6.1)	142	£130	£130	18%
1.4i 16v VVT Turbo (140PS)	18/19	47.1 (6.0)	140	£115	£115	18%
1.4i 16v VVT Turbo (140PS)	20	46.3 (6.1)	142	£130	£130	18%
1.6i 16v Turbo (180PS)	18/19	39.2 (7.2)	168	£265	£190	23%
1.6i 16v Turbo (180PS)	20	39.2 (7.2)	169	£265	£190	23%
Diesel						
2.0CDTi 16v Turbo Diesel (165PS)	18/19	58.9 (4.8)	127	£0	£95	18%
2.0CDTi 16v Turbo Diesel (165PS)	20	57.6 (4.9)	129	£0	£95	18%

*Correct at time of going to press (September 2011). **Taxation information for guidance only. Please take professional advice on your own tax position. Please refer to the Price Guide for further details.

➤ SAFEGUARD YOUR INTERESTS.

Astra GTC is a showcase for Vauxhall's high-tech safety features, with active and passive technology delivering invaluable peace-of-mind.

Astra GTC combines advanced electronic options with proven safety features like front, side and curtain airbags and reinforced passenger safety cell with pre-defined deformation zones. Standard kit includes active-safety front seat head restraints and a Hill Start Assist feature on SRi models; this helps prevent you inadvertently rolling back on a slope by keeping the brakes applied until just the right moment. Dual front seatbelt pre-tensioners and Vauxhall's highly effective pedal release system appear on all versions, while optional highlights include Advanced Adaptive Forward Lighting (AFL) (illustrated opposite) and front and rear parking distance sensors to help you judge tight spaces.



1. Active-safety front seat head restraints. Minimise the risk of whiplash injury and guard against other head and upper body injuries.



2. Tyre pressure monitoring system (TPMS). Monitors the tyre pressure via sensors on the inner sides of the valves and activates a warning display if there is a loss of pressure. Optional at extra cost.

Advanced Adaptive Forward Lighting.

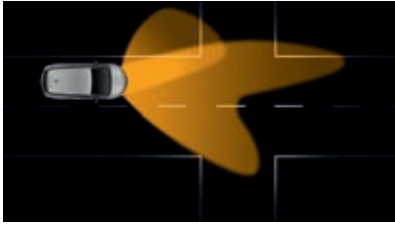

Static cornering light (up to 25mph, also when reversing). Throws light 90 degrees left or right for enhanced lateral vision.



Dynamic curve light (any speed). Activated by steering angle and speed, the headlights swivel up to 15 degrees into the curve.

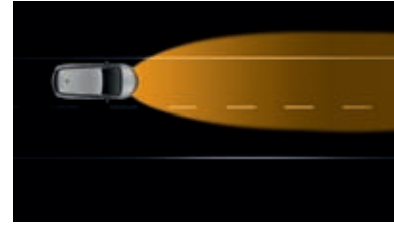

High beam with assist (any speed). Automatically switches from high to low beam as it detects oncoming or proceeding vehicles.



Adverse weather light (up to 45mph). Wiper or rain sensor activated for better vision in bad weather conditions.

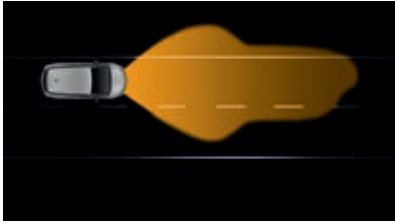

Motorway light (over 60mph). 140 metre range, higher and brighter than normal low beam, without dazzle.

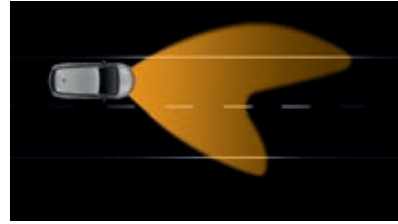

Country road light (30-60mph). Wider spread and brighter light than normal low beam. 70 metre range without dazzle.

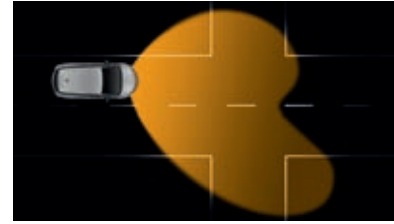

Town light (20-35mph). Wider and lower spread of light. Activated by vehicle speed together with street lighting.

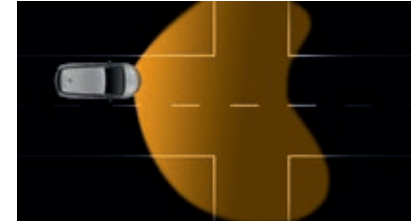

Pedestrian area light (up to 20mph). Wider spread of light (an extra eight degrees left and right) illuminates potential hazards.

➤ **MANAGE YOUR SPACE.**

Astra GTC combines stylish coupé character with genuine hatchback versatility. Comfortably seating up to five people – extremely comfortably if you specify the luxurious leather option – the Astra GTC is a surprisingly practical car for everyday use, with a generous 380 litres of luggage space to boot.



1 and 2. Generous storage features. Stowage facilities are abundant, including a driver's storage compartment (illustrated) situated under the main lighting control, roomy front door pockets, storage pockets on the front seat backs and an illuminated glovebox.

3. Versatile centre console. Providing practicality at your fingertips, all Astra GTC models feature a centre console unit complete with storage area and 12-volt auxiliary power socket. SRi models boast an additional central storage facility with twin covered drinks holders (illustrated right).



SRi model (illustrated left) features: Leather Pack, satellite navigation system, Infinity® Premium Sound System, electronic climate control, rear parking distance sensors and FlexRide, optional at extra cost.

➤ IMPROVE YOUR DRIVETIME.

Keep in touch, entertained and ahead of the queues with the latest premium Astra GTC in-car communication systems, featuring Digital Audio Broadcast (DAB) facility as standard, aux-in socket, USB connection and optional Bluetooth® connectivity.

1. Navi 600 satellite navigation/CD player with MP3 format/stereo radio.

With its seven-inch high resolution colour display and sophisticated audio pedigree – including standard DAB facility – the Navi 600 brings SD card-based memory technology within easy reach of the Astra GTC driver. Navigation data and Points of Interest information is stored on the handy SD-card; this enables high-speed access and allows universal networking with mobile devices and digital data media. Beside fastest and shortest route, the most economical journey can be selected, taking factors like roof and trailer loads into consideration.

Other highlights include:

- AM/FM stereo radio with 36 station presets
- 20 watts per channel output
- Seven speakers
- Steering wheel mounted audio controls





2. CD 400. Standard across the range, the CD 400 raises the bar for in-car entertainment units in this class. Highlights include CD/MP3 CD player, AM/FM stereo radio with 36 station presets, USB connection and aux-in socket, seven speakers, seven-band graphic equaliser, Digital Sound Processor, 4 x 20W output – and excellent sound quality. The CD 400 can be specified with an optional Bluetooth® -ready mobile phone portal and remote control for adjusting volume and other key functions direct from the steering wheel.

3. Infinity® Premium Sound System. The ultimate in Astra GTC audio performance, with 7 x 45 watts (315 watts total), 7 premium speakers and an 8-inch subwoofer. The Infinity system digitises the audio signal so it can be fine tuned with Digital Sound Processing (DSP) for accurate sound response. For you, the difference is better all-round sound production under all driving conditions.

4. Mobile phone portals. Stay in touch with a Bluetooth® connection or a fully integrated phone-specific cradle that charges your battery as you go. The standard system features control from the steering wheel, or via voice phone control. The 'embedded' mobile phone system uses a Bluetooth® connection to copy the content of the mobile phone's SIM, such as the contacts and caller lists etc to the internal flash-drive – effectively transferring much of the phone's capability to the vehicle itself. Both systems are optional at extra cost.

For further details on specification and availability of Astra GTC infotainment systems refer to pages 44 – 45.



CREATE YOUR MODEL.



SPORT.

Feature highlights include:

- Electronic Stability Programme (ESP)
- Six airbags
- Active-safety front seat head restraints
- Daytime running lights
- 18-inch seven-spoke alloy wheels
- Air conditioning
- CD 400 CD/MP3 CD player with stereo radio
- Digital Audio Broadcast stereo receiver
- USB connection with iPod control
- Aux-in
- Electrically operated front windows
- Cruise control
- Remote control central deadlocking
- Steering column adjustable for reach/rake
- Steering wheel mounted audio controls
- Front seat height adjusters
- Remote control alarm system*

Engine availability

Insurance groups (ABI)**

1.4i 16v VVT Turbo (120PS)	13E
1.4i 16v VVT Turbo (140PS)	16E
1.6i 16v Turbo (180PS)	25E
2.0CDTi 16v Turbo Diesel (165PS)	20E

*Optional on Sport 1.4i 16v VVT Turbo (120PS) model.
Standard on all other models.

**Provisional at time of going to press.





> SRi.

Additional features over and above Sport models:

- Sports front seats
- Rain-sensitive windscreen wipers
- Automatic lighting control
- Front fog lights
- Multi-function trip computer
- Electric parking brake
- Hill start assist
- Front centre armrest with storage facility
- Dual-tone horn
- Three-spoke leather-covered steering wheel
- Front door sill covers
- Dark-tinted rear windows

Engine availability	Insurance groups (ABI)*
1.4i 16v VVT Turbo (120PS)	14E
1.4i 16v VVT Turbo (140PS)	16E
1.6i 16v Turbo (180PS)	25E
2.0CDTi 16v Turbo Diesel (165PS)	20E

Model illustrated features FlexRide, front and rear parking distance sensors, Electronic Climate Control, Navi 600 satellite navigation system and Infinity® Premium Sound System, optional at extra cost.

*Provisional at time of going to press.





➤ WHEELS AND TYRES.

Impressive looks demand an impressive set of wheels and Astra GTC doesn't disappoint. Imposing 18-inch alloys are standard issue and stunning 20-inch designs top the options list.



ASTRA GTC SPORT

Please note:

A space-saver spare wheel is available at extra cost in lieu of the emergency tyre inflation kit.



18-inch alloy wheels with 235/50 R 18 low profile tyres (standard on Sport models).



19-inch alloy wheels with 235/45 R 19 ultra-low profile tyres (optional at extra cost on Sport models).

ASTRA GTC SRi



18-inch alloy wheels with 235/50 R 18 low profile tyres (standard on SRi models).



19-inch alloy wheels with 235/45 R 19 ultra-low profile tyres (optional at extra cost on SRi models).



20-inch alloy wheels with 245/40 R 20 ultra-low profile tyres (optional at extra cost on SRi models).

> EXTEND YOUR OPTIONS.

You don't get an Astra GTC to decorate the front drive – you're going to demand a lot more from it than that! With a few well-chosen options, you can make sure you get a great deal more out of those hours spent on the road.





1. Ergonomic sports seats.* The Astra GTC's optional orthopaedic ergonomic six-way adjustable sports driver's seat – in luxurious leather – adjusts to suit your posture, perfectly. Both front seats feature superior side support plus, on the driver's seat, tilt adjustment, electric lumbar support and an extendable seat cushion. Better still, the driver's seat has won the coveted AGR** seal of approval for helping to prevent the in-car back pain and tension suffered by some car occupants. Additional seat option packs are available – please see page 44 for more details.

2. Adjustable seat cushion extension.* The ergonomic sports seat features an adjustable and extendable seat cushion for additional leg support when you're travelling long distances.

3. Electronic Climate Control ECC. Providing constant control of the interior atmosphere via an onscreen display, this fully automatic system features Dual Zone settings so you can set the ideal temperature for either side of the car.

4. Electro-chromatic anti-dazzle rear-view mirror. At night, sensors integrated within the internal rear-view mirror detect following headlights and adjust the brilliance of the reflection to remove glare. To assist parking, the mirror automatically returns to full reflectivity when reverse gear is selected. Standard on SRi models.

*Only available as part of Leather Pack.

**Aktion Gesunder Rücken e.V (AGR) is an independent panel of ergonomics experts and doctors based in Germany.

➤ EXTERIOR COLOURS.

From Power Red to Carbon Flash two-coat metallic, the Astra GTC colours exude excitement and energy – just like the car itself!



SOLID (TWO-COAT)

BRILLIANT

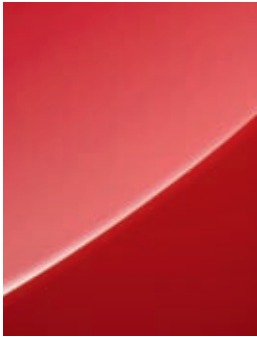

Power Red



Olympic White*



Flaming Yellow*

TWO-COAT METALLIC



Seashell*



Sovereign Silver*



Silver Lake*



Silky Shadow*



Technical Grey*

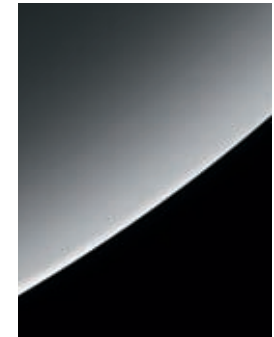

Carbon Flash*

*Optional at extra cost.

Due to the limitations of the printing process, the colours reproduced throughout this brochure may vary slightly from the actual paint colour. As a result, they should be used as a guide only. Your Vauxhall Retailer has a comprehensive display of our paint samples.

> INTERIOR TRIMS.

Astra GTC's interior takes its cue from the athletic lines of the body – enhanced by an equally dynamic choice of fabrics, trims and colours.



SILVANUS CLOTH – DARK GALVANISED



Standard on Sport models.
Available with all exterior colours.

IMOLA/MORROCANA CLOTH – JET BLACK



Standard on SRi models.
Available with all exterior colours.

IMOLA/MORROCANA CLOTH – MORRELLO RED



No cost option on SRi models. Available with all exterior colours except Power Red, Flaming Yellow and Silky Shadow.

Due to the limitations of the printing process, the colours reproduced may vary slightly from the actual trim material. As a result, they should be used as a guide only. Your Vauxhall retailer has a comprehensive display of our trim swatches.

LEATHER – ERGONOMIC SPORT SEAT* – JET BLACK



Optional at extra cost on SRi models.
Available with all exterior colours.

*Ergonomic driver's seat only.

➤ EXPRESS YOUR INDIVIDUALITY.

Whatever you're into, there's certain to be a Genuine Vauxhall Accessory with your name on it, all fitted by trained Vauxhall professionals. We've featured just a small selection of what's available here, so please check with your Vauxhall retailer for Astra GTC accessory information or visit our website at www.vauxhall.co.uk/accessories

1. Cargo tray. Protect your Astra GTC's load area against messy loads with this sturdy boot liner. Specially designed for a tailored fit, it provides maximum protection yet is easily removed for cleaning.

2. Load-restraining floor net. Safeguard your load area and its contents: our elastic restraining net attaches to built-in lashing eyes and is designed to stop large items sliding around in the luggage area.

3. Thule surfboard carrier. Used in conjunction with the Vauxhall base carrier, these quality systems, manufactured by Thule, open up a range of attachments from roof boxes to surfboard carriers to be transported on the roof without damaging your vehicle.

4. Floor mats. Both rubber and velour floor mats (illustrated) are available for your Astra GTC. Both styles sport an Astra logo and have unique fixing points which help keep them firmly in place.



VXR styling products allow you to connect with the performance and excitement at the heart of the VXR brand. Taking that same ethos as our brief we have created a definitive line-up of VXR styling products that will add a degree of individuality to any Astra GTC.



5. VXR Styling Pack. This accessory pack is available for both Astra GTC models, fitted by your Vauxhall retailer and includes the following:

- Front lower spoiler
- Rear lower skirt
- Rear roof spoiler
- Side sills

Further accessories include:

- Mudflaps
- Fixed or detachable tow bars with 7- or 13-pin connection
- Smoker Pack
- Front passenger seat net
- Rear bumper protection film
- Alloy wheels
- Safety Pack
- Door sill covers (standard on SRi models)
- Rear parking distance sensors

SRi model illustrated also features 20-inch alloy wheels and Navi 600 satellite navigation system, optional at extra cost.

Contents

Equipment

Safety and Security	40
Heating and ventilation Facia, instruments and controls Interior lighting	41
Seating and upholstery Additional interior features Mechanical Exterior styling and protection	42
Exterior lighting Exterior and convenience features	43
Option packs Audio, communication and navigation	44
Technical data	
Engines	46
Performance, fuel economy, emissions and VED rates	47
Suspension, fuel tank capacity, steering, brakes, Hill Start Assist, Towing Pack, body Vauxhall Assistance and warranties	48
Exterior dimensions Weights and towing data	49
Features explained	50

Safety

Standard features

Airbags: • Driver's airbag • Front passenger's airbag • Front seat side-impact airbags • Full-size curtain airbags • Deactivation switch for front passenger's front and side-impact airbags – Ensures front passenger airbags do not inflate when a child seat is fitted to the front passenger's seat

Seating: • Active-safety front seat head restraints • Height-adjustable front and outer rear seat head restraints • Five lap and diagonal inertia-reel seatbelts (height-adjustable front) • Front body-lock diagonal seatbelt pretensioner system – Tightens the seatbelt during the early stages of a frontal impact • Drivers and front passenger's lap belt pretensioner system • Front seatbelt force limiters – Reduces potential upper body injuries during a frontal impact • Anti-submarining ramps in front seats – Help prevent occupants sliding underneath the lap belt during a collision • ISOFIX child seat restraint system for outer rear seats incorporating top tether (does not include child seat) – Secures specially designed ISOFIX child safety seats to the vehicle itself, virtually eliminating the dangers that can result from improper installation

Electronic: • Electronic Stability Programme-plus (ESP-plus) – Reduces the possibility of losing control of the vehicle – see **D2** on page 50 • Anti-lock Braking System (ABS) • Electronic Brakeforce Distribution (EBD) • Cornering Brake Control (CBC) – see **D1** on page 50 • Hydraulic Brake Fade Assist – Automatically raises braking pressure to compensate for brake fade under repeated applications of heavy braking • Emergency Brake Assist – Increases brake force applied in emergency braking situations • Straight Line Stability control • Traction control • Adaptive brake lights – If the driver brakes hard enough to activate the ABS function the brake lights flash on and off at a frequency of four times per second, warning following vehicles that heavy braking is in progress

Body: • Energy-absorbing steering column • Pedal release system – Reduces potential injury to the driver's legs and feet during a severe frontal impact • Laminated windscreen • Side-impact protection beams • Reinforced passenger safety cell • Deformation zones front and rear • Burst-proof door locks and anti-jam door design

Additional feature

Tyre pressure monitoring system – see **D4** on page 50

Sport	SRI
-------	-----

○	○
---	---

Security

Standard features • Driver's internal central locking switch • 'Key left in ignition' audible warning • Electronic theft protection for audio equipment • Remote control central deadlocking (doors, tailgate, fuel filler flap) • Electronic engine deadlock immobiliser • Visible Vehicle Identification Number (VIN) plate • Freewheeling door locks • Locking wheel nuts for alloy wheels

Additional feature

Remote control ultrasonic security alarm system

Sport	SRI
-------	-----

● ¹	●
----------------	---

1 = Optional at extra cost on 1.4i 16v VVT Turbo (120PS) model.

Heating and ventilation

Standard features • Air conditioning with air recirculation • Air blend heater with six-speed fan • Side window demist vents and adjustable face-level air vents • Interior pollen filter • Rear passenger compartment heating outlets

Additional feature

	Sport	SRi
Dual-zone Electronic Climate Control (ECC) incorporating air conditioning with humidity sensor	○	○

Facia, instruments and controls

Standard features • Cruise control • Rev counter • Multi-function display showing time, date, audio information and outside air temperature • Digital clock with automatic RDS time adjustment • Steering column adjustable for reach and rake • Electronic odometer and trip odometer • Instrument panel light dimmer • Parking brake-on/low brake fluid level and low fuel level warning lights • Service interval monitor • Seatbelt unfastened warning light (front seats only)

Additional features

	Sport	SRi
Electric parking brake incorporating Hill Start Assist (HSA)		●
Three-spoke chrome-bezelled steering wheel	●	
Three-spoke chrome-bezelled leather-covered steering wheel		●
Leather-covered gear knob (manual models only)		●
Black instruments with chrome edging	●	
Translucent instruments with chrome edging		●
Multi-function trip computer (instantaneous fuel consumption, average fuel consumption, range remaining, two trip odometers running concurrently, instantaneous speed, average speed)		●

Interior lighting

Standard features • Fade up/fade down courtesy lights operated by door switches • Map reading lights integral with front courtesy light • Ambient lighting in centre console surround • Illuminated glovebox and luggage area

Additional feature

	Sport	SRi
Ambient lighting in front doors		●

● = Standard equipment. ○ = Optional at extra cost.



ISOFIX child seat restraint system.



Dual-zone Electronic Climate Control (ECC).



Cruise control.



FlexRide sport button.



Folding key.



Chrome-effect internal door handles.

Seating and upholstery

Standard features • Driver's and front passenger's seats with height, reach and recline adjustment • 60/40 split-folding rear seat back • Storage pockets on front seat backs

Additional features	Sport	SRI
Silvanus cloth seat trim	●	
Jet Black Imola cloth seat trim with Morrocana-trimmed side bolsters		●
Morrello Red Imola cloth seat trim with Morrocana-trimmed side bolsters		○
Leather seat facings (includes heated front seats with variable temperature settings)		□
Sports front seats		●

Additional interior features

Standard features • 12-volt auxiliary power socket within front centre console • Twin sunvisors incorporating illuminated driver's and front passenger's vanity mirrors with covers • Chrome-effect internal door handles • Storage box on driver's side lower fascia • Front door pockets • Fully carpeted luggage area • Load restraint lashing eyes • Luggage compartment cover

Additional features	Sport	SRI
Driver's sunglasses holder		●
Dolomite pearl-effect centre console and door inserts	●	
Titanium-effect centre console and door inserts		●
Central storage facility with twin covered drinks holders		●
Electro-chromatic anti-dazzle rear-view mirror – see D3 on page 50	□	●

Mechanical

Standard features • HiPerStrut (High Performance Strut) front suspension • Semi-independent rear suspension with Watt's link and gas-pressure dampers • Sports suspension • Power-assisted steering • Six-speed manual gearbox

Additional feature	Sport	SRI
FlexRide adaptive chassis control system with Continuous Damping Control (CDC) – see D5 and D6 on page 51	○	○

Exterior styling and protection

Standard features • Body-colour door handles • Body-colour door mirrors • Chrome-effect upper grille surround • Black trim on door pillars

Additional features	Sport	SRI
Chrome-effect front door sill covers and upper side window mouldings		●
Visible stainless steel exhaust tailpipe (excludes 1.4i 16v VVT Turbo (120PS))	●	●

Exterior lighting

Standard features • Lights-on audible warning • LED centre brake light • Reversing light, rear fog light, hazard warning lights, side repeat indicators • Ellipsoid headlights • Electric headlight beam levelling • Dark-style headlights • Daytime running lights • Dark-style tail lights

Additional features

	Sport	SRi
Intelligent Adaptive Forward Lighting (AFL) incorporating dark-style bi-xenon headlights with dynamic beam levelling, LED daytime running lights and high-pressure headlight washers	<input type="checkbox"/>	<input type="checkbox"/>
Front fog lights		●
Automatic lighting control with tunnel detection and digital high beam assist	<input type="checkbox"/>	●
LED rear lights	<input type="radio"/>	<input type="radio"/>

Exterior and convenience features

Standard features • Electrically operated front windows with safety autoreverse and one-touch facility • Twin electrically adjustable/heated door mirrors (wide angle on driver's side) • Manually foldable door mirrors • Tinted glass • Windscreen wipers with variable intermittent facility and flick-wipe • Twin-jet windscreen washer nozzles • Heated rear window with automatic timed cut-off • Intermittent rear window wash/wipe • Gas-assisted tailgate struts • Folding key

Additional features

	Sport	SRi
Hill Start Assist (HSA)		●
Electrically foldable door mirrors	<input type="radio"/>	<input type="radio"/>
Rain-sensitive windscreen wipers	<input type="checkbox"/>	●
Dark-tinted rear windows	<input type="radio"/>	●
Front and rear parking distance sensors	<input type="radio"/>	<input type="radio"/>
Two-tone horn		●

● = Standard equipment. ○ = Optional at extra cost. □ = Only available as part of an extra-cost option pack (see page 44 for details).



Front and rear parking distance sensors.



Automatic lighting control.



Front fog lights.



LED daytime running lights.



Electro-chromatic rear view mirror.



Steering wheel mounted audio controls.

Option packs

	Sport	SRi
Sight and Light Pack • Automatic lighting control with tunnel detection • Rain-sensitive windscreen wipers • Electro-chromatic anti-dazzle rear-view mirror • Digital high beam assist	○	●
Leather Pack • Leather seat facings • Electrically heated front seats • Driver's ergonomic sports front seat • Front passenger's extendable seat cushion		○
Seat Comfort Pack One • Driver's seat with six-way manual adjustment and four-way electrical lumbar adjustment	○	○
Seat Comfort Pack Two • Driver's and front passenger's seat with six-way manual adjustment and four-way electrical lumbar adjustment	○	○
Premium Forward Lighting Pack • Intelligent Adaptive Forward Lighting (AFL) • Dark-style bi-xenon headlights with dynamic beam levelling • LED daytime running lights • High-pressure headlight washers	○	○
Towing Pack • Detachable tow bar • Trailer stability programme	○	○

Audio, communication and navigation

Features	Sport	SRi
CD/MP3 CD player/stereo radio (CD 400) • CD/MP3 CD player • AM/FM stereo radio with 36 station presets • Aux-in • RDS with Traffic Programme • Graphic display • 20 watts per channel output • 7 speakers • Roof mounted flexible aerial	●	●
Satellite navigation/CD/MP3 CD player/stereo radio (Navi 600) • Satellite navigation system • Street level mapping for UK and Ireland • Major route mapping for more than 30 European countries • CD/MP3 CD player • SD card slot and aux-in • AM/FM stereo radio with 36 station presets • RDS with Traffic Programme • Remote colour monitor • 20 watts per channel output • 7 speakers • Shark fin/integrated aerial	○	○
Infinity® Premium Sound System¹ • 7 x 45 Watt amplifier (315 Watt total) • Digital Sound Processor (DSP) • One front mounted 3.5-inch medium range speaker • Two A-pillar mounted 1-inch tweeters • Two front door mounted 6.5-inch subwoofers • Two rear mounted 6.5-inch wide-band speakers • One 8-inch subwoofer box in luggage compartment	○	○
Digital Audio Broadcast (DAB) stereo receiver with integrated aerial	●	●
USB connection with iPod control	●	●
Steering wheel mounted audio controls	●	●
Bluetooth mobile phone system (does not include phone)	○	○
Embedded Bluetooth mobile phone system with (does not include phone)	○	○

● = Standard equipment. ○ = Optional at extra cost. 1 = Adds Flex Floor luggage compartment.

Satellite navigation

The optional Navi 600 satellite navigation system offers dynamic route guidance via RDS-TMC (Traffic Message Channel) with directions given audibly and via the 7-inch colour monitor. TMC is a specific application of RDS used for broadcasting real-time traffic information. It alerts the driver to a problem on the planned route and calculates an alternative route to avoid the incident.

In addition to route planning criteria such as 'shortest distance' or 'avoiding toll roads', you can now select an energy-optimised 'green route'. Here you can specify parameters such as if you are towing a caravan or have a roof box fitted. The system will use this information, in conjunction with known factors including your vehicle's weight and engine type, to calculate the most fuel-efficient route.

The SD card supplied with the system covers all major link roads and streets in towns and cities across mainland Britain and Ireland, plus trunk and main roads across more than 30 European countries. Additional country-specific maps with street level detail are available to download. The navigation data is loaded onto the unit's internal flash memory for fast access. The CD player plays regular audio CDs and MP3 tracks recorded to CD.

USB connection

Fitted as standard, the USB connection is located alongside the aux-in within the centre console. It provides iPod control and read-out of iPod functions through the audio system display. Traditional aux-in only allow control of volume through the car's audio system. The USB connection also means that the iPod will charge whilst it is connected.

Digital Audio Broadcast (DAB) facility

Now widely available in the UK, digital audio broadcasts offer the user a variety of advantages over traditional FM, starting with the digital quality sound which is immune to any hiss or crackle.

You'll often find a broader range of stations on offer too, many of which are not available on FM, and listening to them couldn't be easier – you simply select the station, by name, from the displayed list, thus removing the need to retune or look for stations when travelling around. Some stations will even display the artists' names and song titles on the car's graphic display, while they're played.

Bluetooth mobile phone system with voice activation

Vauxhall's optional factory-fit dual-band Bluetooth system has been considerably enhanced. Now fully integrated to the audio and communication system, it also features voice control for certain functions.

All the required information is displayed on the graphic information display when a mobile phone is in use, while the menus are easily navigated by either the steering wheel audio controls or the multi-function button on the radio.

Embedded Bluetooth mobile phone system with voice activation

This is the next generation of in-car Bluetooth mobile phone systems. The mobile phone's contacts, caller lists and phone settings are downloaded to the in-car flash drive and, once this synchronisation is complete, the car effectively becomes the phone.

The mobile phone will sit in standby mode and the Bluetooth® function will no longer drain the battery, whilst all calls will be transmitted via the car's, rather than the mobile phone's, aerial.

Any alterations that have been made to the contacts, caller lists etc. whilst the units have been synchronised will be transferred back to the mobile phone.

Infinity® Premium Sound System

For the ultimate in premium sound performance Astra GTC can also be specified with the Infinity Sound System. Featuring a 7x 45 Watt amplifier and Digital Sound Processor, the system comprises eight premium speakers, including one rear-mounted 8-inch subwoofer, two door-mounted and two rear mounted 6.5-inch wide band speakers, two 1-inch tweeters mounted in the A-pillar and a front-mounted 3.5-inch medium range unit. The unit is optional at extra cost on all models.



Satellite navigation.



Shark fin aerial.



USB connection and aux-in socket.

Power and torque curves

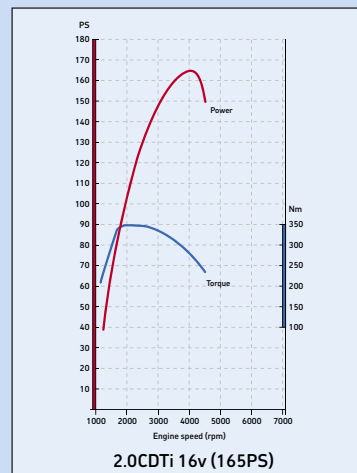
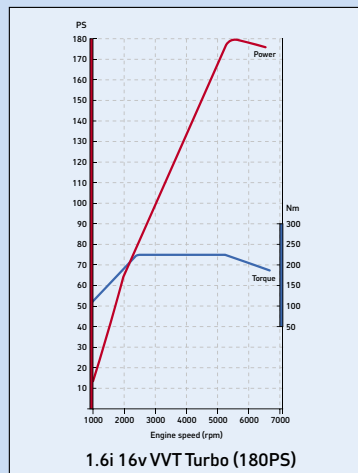
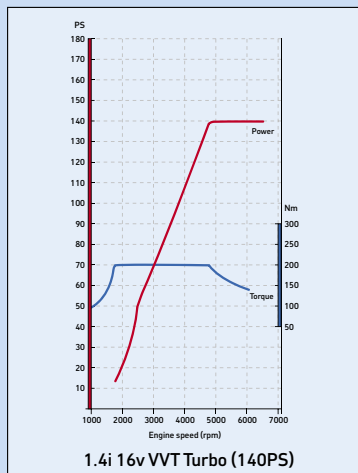
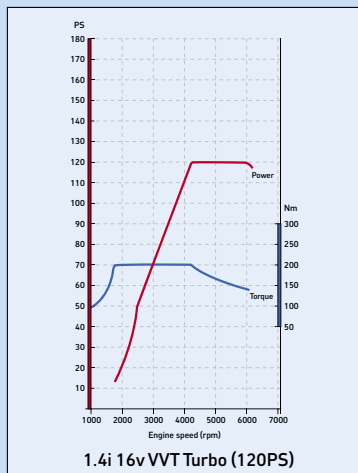

Engines

	1.4i 16v VVT Turbo (120PS) ECOTEC-4 with Start/Stop	1.4i 16v VVT Turbo (140PS) ECOTEC-4 with Start/Stop	1.6i 16v VVT Turbo ECOTEC-4	2.0CDTi 16v ECOTEC-4 Turbo diesel with Start/Stop
Fuel type	Petrol	Petrol	Petrol	Diesel
Capacity	1364cc	1364cc	1598cc	1956cc
Maximum power	120PS (88kW) @ 4200-6000rpm	140PS (103kW) @ 4900-6000rpm	180PS (132kW) @ 5500rpm	165PS (121kW) @ 4000rpm
Maximum torque	200Nm (147 lb.ft.) @ 1850-4200rpm	200Nm (147 lb.ft.) @ 1850-4900rpm	230Nm (169 lb.ft.) @ 2200-5400rpm	350Nm (258 lb.ft.) @ 1750-2500rpm
Configuration	4 cylinders, 4 valves per cylinder, double overhead camshafts			
Fuel/induction system	Water-cooled turbocharger with intercooler. Variable Valve Timing (VVT). Multi-point sequential fuel injection			Variable geometry turbocharger with intercooler. Common rail fuel injection. Diesel Particulate Filter
Emission compliance	Euro 5			
Service interval	20,000 miles or 1 year (whichever occurs sooner)			
<i>Benefit in kind company car taxation – 2011/12 tax year</i>				
Manual	18%	18%	23%	18%

Performance, fuel economy, emissions and VED rates

	Wheel size (inches)	Performance (manufacturer's figures)		Fuel economy mpg (litres/100km)			CO ₂ emissions g/km	VED**	
		Maximum speed (mph)	Acceleration 0-60mph (sec)	Urban driving	Extra-urban driving	Combined figure		First year rate	Standard rate
Petrol manual									
1.4i 16v VVT Turbo (120PS) Start/Stop	18/19	119	10.2	36.2 (7.8)	57.6 (4.9)	47.1 (6.0)	140	£115	£115
1.4i 16v VVT Turbo (120PS) Start/Stop	20	119	10.2	36.2 (7.8)	56.5 (5.0)	46.3 (6.1)	142	£130	£130
1.4i 16v VVT Turbo (140PS) Start/Stop	18/19	125	9.0	36.2 (7.8)	57.6 (4.9)	47.1 (6.0)	140	£115	£115
1.4i 16v VVT Turbo (140PS) Start/Stop	20	125	9.0	36.2 (7.8)	56.5 (5.0)	46.3 (6.1)	142	£130	£130
1.6i 16v VVT Turbo	18/19	137	7.8	30.4 (9.3)	47.9 (5.9)	39.2 (7.2)	168	£265	£190
1.6i 16v VVT Turbo	20	137	7.8	30.4 (9.3)	47.1 (6.0)	39.2 (7.2)	169	£265	£190
Diesel manual									
2.0CDTi 16v Start/Stop	18/19	131	8.4	49.6 (5.7)	65.7 (4.3)	58.9 (4.8)	127	£0	£95
2.0CDTi 16v Start/Stop	20	131	8.4	48.7 (5.8)	64.2 (4.4)	57.6 (4.9)	129	£0	£95

**VED = Vehicle Excise Duty. Correct at time of publication (September 2011).

Fuel consumption and CO₂ emission data complies with the relevant EU testing regulations used by vehicle manufacturers to enable comparisons between different models. **Important:** Please note fuel consumption can be affected by many factors including driving style, road and traffic conditions, vehicle mileage and standard of maintenance. In addition these results relate to the particular vehicle tested, inevitably there will be differences between individual vehicles of the same model.

Start/Stop technology

Astra GTC's Start/Stop system offers real benefits by improving fuel economy and reducing CO₂ emissions, particularly when driving around town. It does this by automatically stopping the engine when you come to a standstill, and then restarting as you prepare to move off.

To operate the system, the driver must depress

the clutch pedal, shift in to neutral, and then release the clutch pedal.

If all of these conditions are satisfied then the vehicle will Auto Stop. When you are ready to pull away from standstill, Auto Restart is activated by depressing the clutch pedal. Whilst at a standstill the vehicle is continually monitored, and if necessary, the engine will automatically be restarted.

The system monitors many different criteria to ensure effective operation:

- Battery charge
- Outside air temperature and engine temperature
- Demand from auxiliary components such as climate control (when fitted)



Compound crank rear suspension includes innovative use of Watt's link.



Watt's link improves handling and ride comfort.

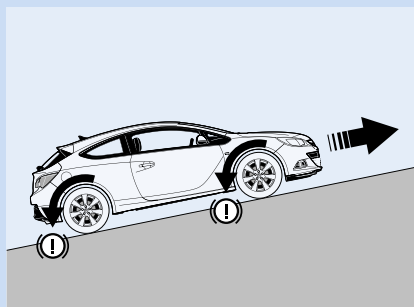

Hill Start Assist (HSA).

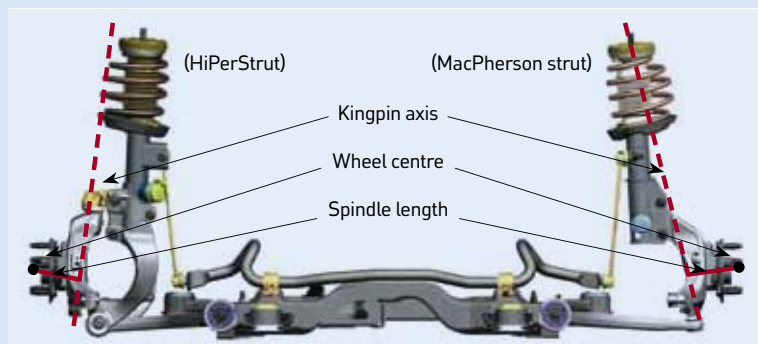

Suspension

The HiPerStrut (High Performance Strut) front suspension improves grip and allows more power to be applied during cornering. The reduced kingpin angle means less camber loss, which allows the front tyres to retain more of their contact patch with the road during cornering, therefore delaying the onset of understeer. The shorter spindle length significantly reduces torque steer reactions and improves resistance to steering kickback through uneven bends.

Front: Independent. HiPerStrut sports suspension with gas-pressure dampers and coil springs. Anti-roll bar.

Rear: Lightweight compound crank rear axle with one-piece, hollow cast trailing arms. Built-in anti-roll bar. Progressive-rate double conical mini-block springs with Watt's link and gas-pressure dampers.

Fuel tank capacity

56 litres (12.3 gallons)

Steering

- Power-assisted steering
- Turning circle (kerb-to-kerb):
 - all models 10.9m (35.7ft.)

Brakes

- Anti-lock Braking System (ABS)
- Electronic Brakeforce Distribution
- Hydraulic Brake Fade Assist
- Cornering Brake Control
- Emergency Brake Assist
- Electric parking brake with Hill Start Assist (HSA) (standard on SRi models)

Hill Start Assist (HSA)

Hill Start Assist (standard on SRi models) maintains the brake pressure for a short period after the brake pedal has been released when pulling away on a gradient of 5% or more; this helps prevent the vehicle from rolling back. The pressure is released as soon as the driver presses the accelerator and the car begins to move forward. This ensures improved hill starting for increased comfort and safety.

Towing Pack with trailer stability programme

This sensor controlled system detects when a trailer begins to yaw or becomes unstable and activates the appropriate brakes to compensate.

The detachable tow bar can be easily stored when not in use. This provides added convenience compared to conventional tow bars. Optional at extra cost.

Body

Aerodynamic drag co-efficient:
– Cd 0.33

Vauxhall Assistance and warranties

See back cover for details of our comprehensive warranties.



Exterior dimensions millimetres (inches)

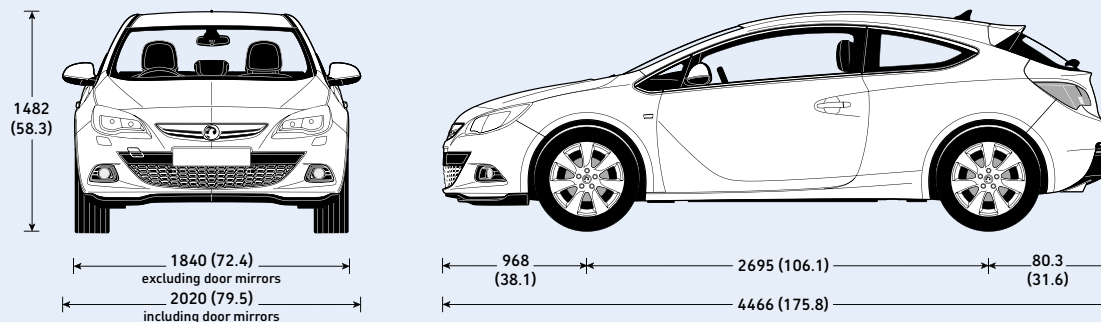

Weights and towing data kg

	Gross vehicle weight	Maximum towing weights Trailer with brakes (without brakes)
1.4i 16v VVT Turbo (120PS) Start/Stop	1960	1100 (730)
1.4i 16v VVT Turbo (140PS) Start/Stop	1960	1300 (730)
1.6i 16v VVT Turbo	1965	1500 (730)
2.0CDTi 16v Start/Stop	2040	1500 (730)

Gross vehicle weight is the total permissible weight of the vehicle including passengers and their luggage. The **maximum roof rack loading** should not exceed 100kg. The **maximum towing weights** are based on the ability of the car, with two occupants of 75kg each, to restart on a 12% gradient, which is approximately 1 in 8.3 at sea level. At altitudes above 1500 metres, the engine output may drop with a corresponding reduction in towing capability. Any extra weight, such as luggage or additional passengers, should be deducted from the maximum towing weight. With a trailer fully loaded, **maximum nose weight** should not exceed 75kg. Always fit Vauxhall towing attachments and accessories available from your Vauxhall retailer. They are designed specifically for Vauxhall models and carry a 12-month guarantee.

Luggage capacities* litres (cu. ft.)

Rear seats up	380 (13.4)
Rear seats down	1165 (41.1)

Please note fitment of Infinity® Sound System reduces load volume by 38 litres.

* = Measured using the ECIE method.

Vauxhall supporting



Smarter driving tips

- **Drive at an appropriate speed:** Staying within the speed limit increases driver safety, reduces CO₂ emissions and saves fuel. At 70mph you could be using up to 9% more fuel than at 60mph and up to 15% more fuel than at 50mph
- **Drive smoothly at all times:** Anticipate the ebb and flow of the traffic to avoid harsh acceleration and braking
- **Reduce your revs:** Change gear earlier to help reduce fuel consumption – try 2500rpm with petrol engines and 2000rpm with diesel
- **Idling is wasting fuel:** If you're likely to be at a standstill for more than three minutes, switch off the engine to save fuel
- **Regularly check your tyre pressures:** Under inflated tyres increase CO₂ emissions whilst incorrectly inflated tyres can be unsafe. Always check your handbook for the correct tyre pressure. This will also help to increase the life of your tyres
- **Remove unnecessary items from the car:** Extra weight increases the engine's workload, whilst roof racks and bike carriers increase wind resistance. All burn more fuel and increase CO₂ emissions

Features explained

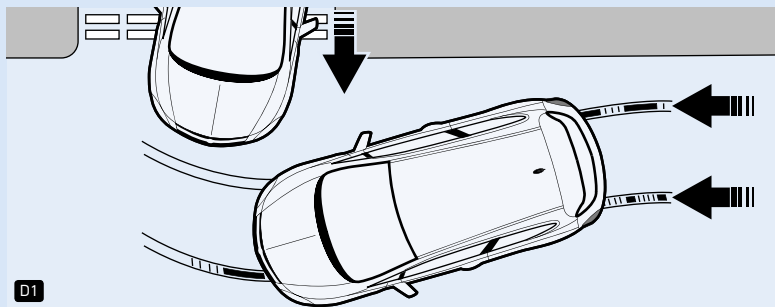

Anti-lock Braking System (ABS) with Cornering Brake Control (CBC)

D1. Cornering brake control makes the car easier to control in extreme situations, for example when braking sharply on a bend. It is particularly effective when carrying out emergency procedures, such as avoiding a child's ball that's rolled out from the kerb. The system works by sensing the different rotational speeds of the individual road wheels and co-ordinating the level of braking pressure applied to each wheel. CBC is an integral part of Astra GTC's comprehensive ABS.

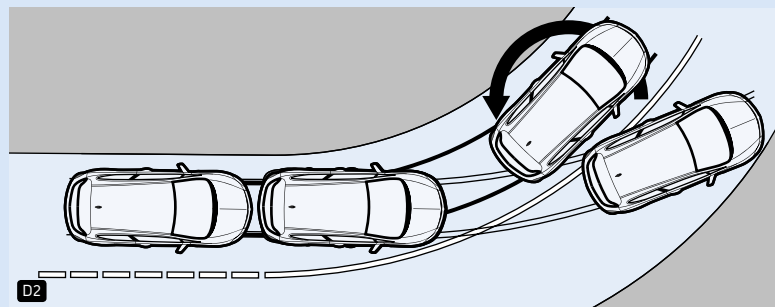

Electronic Stability Programme-plus (ESP-plus)

D2. ESP-plus provides enhanced yaw compensation during understeer or oversteer. It works by monitoring the front and rear of the car and comparing their respective directions of travel with the input through the steering wheel. If the vehicle starts to slide, ESP-plus applies corrective braking to the appropriate wheel, or wheels, compensating for the slide and helping you regain control more rapidly. ESP-plus offers additional safety in the form of two-way traction control, which helps prevent the driving wheels from spinning, under acceleration, on slippery surfaces.

Sight and Light Pack optional on Sport, standard on SRi – consisting of:

Automatic lighting control with tunnel detection

When the main lighting control is set to 'Auto' Astra GTC's headlights switch on automatically when you enter a tunnel or when darkness descends.

Rain-sensitive windscreen wipers

Activated by a sensor mounted in the rear-view mirror housing, the windscreen wipers switch on automatically when they sense rain on the screen and adjust their wiping speed to suit the prevailing conditions.



Electro-chromatic anti-dazzle rear-view mirror

D3. At night, sensors integrated within the internal rear-view mirror detect following headlights and adjust the brilliance of the reflection to remove glare. To assist parking, the mirror automatically returns to full reflectivity when reverse gear is selected.



Tyre Pressure Monitoring System (TPMS)

D4. Optional at extra cost on all models, TPMS monitors the tyre pressure via sensors on the inner sides of the valves and activates a warning display if there is a loss of pressure.



Left hand drive model illustrated.

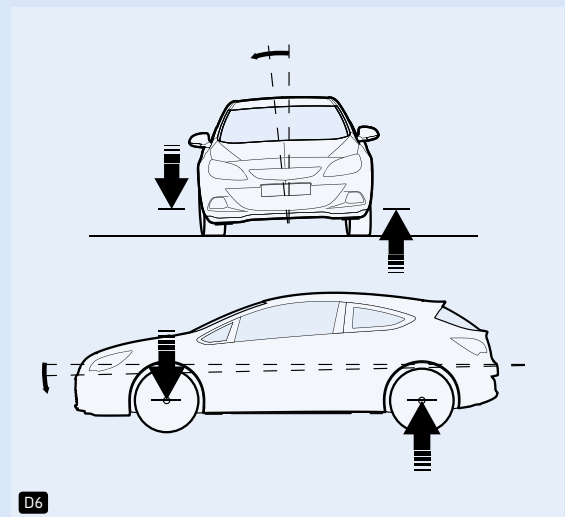

Optional FlexRide chassis with Drive Mode Control (DMC)

D5. An integrated, fully adaptive chassis control system that significantly enhances Astra GTC ride, handling performance – and safety. The electronic brain behind FlexRide is the Drive Mode Control (DMC) module. Utilising sophisticated vehicle dynamics information, DMC constantly monitors up to 11 different driving dynamic variables – including acceleration, braking and cornering – and optimises the behaviour of the chassis accordingly. DMC also analyses the chosen FlexRide drive mode selected by the driver. Another key function is the monitoring of driving style. DMC recognises if the driver is driving normally or sportily and adapts chassis performance to match. In addition, FlexRide offers important safety benefits in emergency situations: for example, if an ‘unusual’ manoeuvre is detected the dampers are stiffened by one level (i.e. from Normal to Sport mode) within milliseconds.

Continuous Damping Control (CDC)

D6. The heart of the FlexRide system is its Continuous Damping Control (CDC) technology – this uses a series of electronic sensors to constantly monitor and control the suspension for optimum stability, driver engagement and comfort. In simple terms, CDC, the four-channel Anti-lock Braking System (with Electronic Brakeforce Distribution), traction control and Electronic Stability Programme-plus (ESP-plus) all communicate with each other, continuously, to optimum effect. The process occurs 100 times per second, equivalent to intervals of around 12 inches at a speed of 62mph. Based on this information, the adaptive damping system continually optimises body control by changing the damping force in real time. For example, when braking the dampers are

adjusted accordingly, avoiding excessive body pitch and promoting more comfortable braking behaviour. Fast steering manoeuvres are detected via changes to the steering angle, and here the damping is changed to a firmer setting, reducing body roll, giving a safer, smoother, more comfortable drive.

Sport mode

Select Sport mode and FlexRide not only provides stiffer damping, but also swifter throttle response and sharpened speed-sensitive power steering for more dynamic driving. A customisation menu, accessible via the facia display, allows the driver to personalise the Sport mode by specifying which functions are activated when the Sport button is pushed. For instance, the electronically controlled dampers and steering can be added or switched off. The instrument lighting switches from white to red adding to the driving experience.

Tour mode

Ideal for long motorway journeys, the Tour mode adjusts the dampers to a softer setting to create a perceptibly smoother ride and further enhance Astra GTC’s ride comfort.

Normal mode

In Normal mode. The dampers permanently adapt to changing driving conditions, providing more comfort than a conventional chassis but with improved cornering behaviour and better steering response in quickly changing traffic situations.

Trust Vauxhall

Vauxhall Insurance

Available for new and used Vauxhalls, a Vauxhall Insurance policy offers a unique package designed specifically for Vauxhall drivers. For a highly competitive quotation, call **0844 463 2670**. Or just visit our website at www.vauxhall.co.uk

Fleet Customer Services

Our dedicated support services for fleet managers includes factory demonstrators, a three-day test drive programme and information on whole life costs, company car taxation and finance. For further information please call **0870 010 0651**.

Buying your car

GMAC offers one of the most comprehensive and competitive ranges of financing plans in the UK. Contact your local Vauxhall retailer for details or call the GMAC customer service centre on **0845 712 3444**.

Servicing and maintenance

The best way to maximise the performance and reliability of your Vauxhall is to have all routine servicing and maintenance carried out at one of around 400 Vauxhall retailers. To find your nearest retailer call **0845 600 1500**.

In the event of an accident...

Vauxhall Accident Support helps keep you mobile following an accident. Benefits include scene-of-accident advice, message service, assistance with claims and vehicle recovery. For further details call **0800 010 304**.

Proud Sponsor of Home Nations Football



For more information...

For a brochure on any Vauxhall model (up to a maximum of three per caller) or location of your nearest Vauxhall retailer please call **0845 600 1500**.

Alternatively, details can be found on our website at www.vauxhall.co.uk

Join us online:



Scan this QR code with your smartphone for more information. Don't forget to download a QR reader from your app store first.

Vauxhall Lifetime Warranty

We're so confident in Vauxhall quality and reliability that we are now able to offer a lifetime warranty. Available to the first owner of all new Vauxhall passenger cars, it's valid for the lifetime of the vehicle up to a maximum of 100,000 miles*. In addition, our warranty also includes Vauxhall Assistance for 12 months from first registration and six years body panel anti-perforation warranty. Full details of Vauxhall's warranties including terms, conditions and exclusions can be obtained through any authorised Vauxhall Retailer or go to: www.vauxhall.co.uk/warranty



When you have finished with this brochure please recycle it

*Vauxhall Lifetime Warranty covers lifetime ownership of first car owner, 100,000 mile limit, annual check required. The warranty excludes wear and tear and serviceable items and the vehicle must be serviced in accordance with the manufacturer's servicing schedule to continue the lifetime warranty. Terms and conditions apply. Offer available to all Vauxhall passenger cars (this offer does not apply to car-derived vans) from 1st August 2010.

Every effort has been made to ensure that the contents of this publication were accurate and up-to-date at the time of going to press (September 2011). Vauxhall vehicles are equipped with components manufactured by various General Motors operating units and outside suppliers. The Company reserves the right to alter specifications and withdraw products from sale without notice. Any such alterations will be notified to Vauxhall retailers at the earliest opportunity, please consult your local retailer for the latest information. The specifications detailed within this brochure are not necessarily applicable to alternative models such as Special Editions. Details of any such models will be contained in specific literature or found on the Vauxhall website. Please note that Vauxhall retailers are not the agents of General Motors UK Limited and are not authorised to bind the Company by any specific or implied undertaking or representation. It is advisable to ensure that your motor insurance policy provides adequate cover for additional fitted options and accessories. Please note accessories shown are for illustrative purposes only. As part of Vauxhall's policy of environmental care, this brochure is printed on paper manufactured using Elemental Chlorine Free pulps from specially farmed, sustainable timber resources. All rights reserved. No part of this publication may be reproduced in any form or by any means, without the prior written permission of General Motors UK Limited.



VAUXHALL