

# Meriva

2008 Models Edition 2







# A clever family car from Vauxhall

Looking for a compact MPV that's easy to park and manoeuvre around town? A car that makes rear passengers of all ages feel as welcome as those in the front – with adjustable rear seats that fit family members of all sizes and their luggage? Check out the latest Meriva models from Vauxhall. With fresh style, lively engine choices and great features throughout, today's Meriva fits your family's lifestyle – effortlessly.

Think Meriva. How clever is that?

*This brochure covers Meriva Expression, Life, Club and Design models only. Some of the vehicles shown include options and accessories available at extra cost. And not all of the features described are available on every model. So please check in the Equipment section for further details. From time to time, we also offer alternative Meriva models such as Special Editions, featured in their own separate literature or found on the Vauxhall website: [www.vauxhall.co.uk](http://www.vauxhall.co.uk)*

FlexSpace® 6

Environmental issues 12

Safety 14

Driving dynamics 16

Engines and transmissions 18

Features 20

Meriva line-up 24

Options and accessories 30

Meriva VXR 36

Colours and trims 40

Equipment 44

Technical data 50







**Stylish.**  
**Compact.**  
**Spacious.**

And always fun.

With sharp lines and brilliant detailing, Meriva has bags of visual appeal. And everything is designed to make life that little bit easier, whether you're loading up at the supermarket, finding a place to park or simply heading off for a great day out.



Extra legroom?  
Extra bag room?  
Extra flexibility?

Welcome to  
FlexSpace.®











Loads of seating positions.  
Loads of ways to make  
life easier.

And keep the  
family happy.

Meriva's FlexSpace® seating system is all about finding simple ways to accommodate every family transport need, however unexpected, without removing the seats. With rear seats that move backwards, forwards – even sideways – and a 40/20/40 split-folding seat back, Meriva can always make room for friends, family and luggage – plus all the children's bags or buggies. You can even recline the outer rear seats back for a more relaxed seating position.

Feel the light.  
Enjoy the view.  
And relax.

Superb visibility. A fresher, brighter interior. And a higher seating position. The benefits of Meriva's tall yet compact styling are clearly evident in every department. And that's not simply from the driver's perspective. The advantages include more light. More space. More comfort. And an altogether sunnier outlook. Wherever you're sitting!











# Respect your world.

We all share a responsibility to look after our world. That's why Vauxhall has always been at the forefront of green automotive initiatives. Most recently, we are looking at ways to further reduce vehicle CO<sub>2</sub> emissions and working on even cleaner, alternative power sources, including zero-emission fuel cell technology.

But our commitment to preserving the environment goes even further. We have dramatically reduced manufacturing emissions, for example, and our new vehicles use more recycled materials and more recyclable parts than ever before.

We also offer free and easily accessible, environmentally friendly, end-of-life vehicle disposal through our partners Autogreen Ltd. And under our EcoFlex Scrap Allowance\* programme, if you buy a selected low-emission Meriva model, we'll even offer you £1000 to take your old, higher emission car off the road.

That way, we reduce our environmental impact in every phase of every vehicle's life cycle. Because your world is our world, too.

\*Terms and conditions apply. Please ask your Retailer for details.



## Safety for the whole family.

With a 4-star EuroNCAP adult occupancy rating, you don't need a family to appreciate Meriva's many safety features. Every model comes with twin front airbags, front seatbelt pretensioners and side-impact protection beams. All three rear seats are equipped with adjustable head restraints and lap and diagonal seatbelts – the centre belt pulls down from the headlining.





**ISOFIX child seat restraint system.**

Every Meriva is fitted with ISOFIX child seat restraint fittings on both outer rear seats, with front passenger seat fittings optional as part of the Protection Pack. Used in conjunction with Vauxhall accessory child safety seats, the rigid ISOFIX anchoring mechanism virtually eliminates the dangers that can result from incorrect child seat installation. The Vauxhall ISOFIX child seat (see page 34), simply clicks into the mounting points engineered into the car.

**Airbags.** Every Meriva features driver and front passenger airbags as standard. Front seat side-impact airbags and full-size curtain airbags are available as part of the optional Protection Pack, along with active-safety front seat head restraints and other important safety features.



**Adaptive Forward Lighting (AFL).**

Optional on Meriva Club and Design models this sophisticated halogen lighting system moves the headlight beams up to 15 degrees left or right when you turn the steering wheel, helping improve your vision of the approaching bend. Further explanation can be found in the Technical data section on page 53.



**Powerful lighting.** Halogen headlights with electric headlight beam levelling are standard on every Meriva. And front fog lights, standard on Design and optional as part of the Club Plus Pack, help you see even more clearly, and arrive safely, in the most demanding of weather conditions.



Adult occupant rating

**Security.** The hard work we've put into securing your belongings has also led to low, money-saving Meriva insurance group ratings. Features include an engine deadlock immobiliser, remote control central deadlocking and a visible vehicle identification number.



◀ **Tinted rear lights.** Extra safety with style. Meriva's pillar-mounted rear lights increase visibility for following drivers whilst integrating perfectly into the car's smooth rear styling. High mounting also keeps them out of harm's way, protecting against accidental parking damage.

▶ **Driving dynamics.** A family car that's great to drive. Meriva gives you a real feeling of confidence at the wheel – secure in the corners and agile in all conditions. The ride is beautifully balanced – no matter how many people you have on board. And the availability of intelligent chassis features like Dynamic SAFety (DSA) suspension – which enhances stability when braking on surfaces with differing levels of grip on either side of the vehicle – anti-lock brakes and traction control adds the sort of active safety you would expect from Vauxhall.

**ABS.** Meriva's Anti-lock Braking System (ABS) with Electronic Brakeforce Distribution (EBD) and Emergency Brake Assist (EBA) can reduce emergency stopping distances, particularly on slippery roads. It prevents the wheels from locking up and allows drivers to retain steering control.

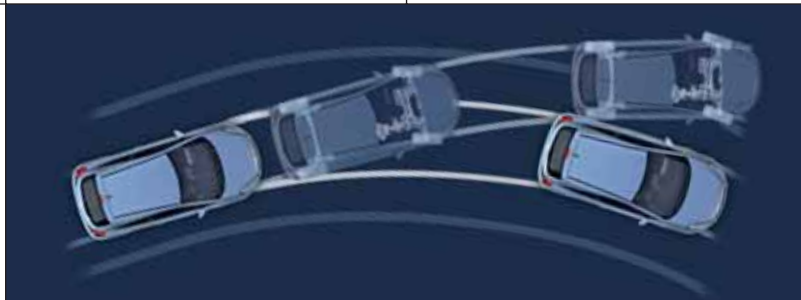

▶ **ESP and Traction Control.** Electronic Stability Programme (ESP) helps you maintain control during adverse or emergency conditions. If the car begins to slide, ESP gently applies corrective braking to the appropriate road wheel to help you regain control. Traction Control (TC) helps prevent wheelspin during acceleration. Further explanation can be found in the Technical data section on page 53.



## Where driving becomes a real pleasure.

Meriva is not just great fun to drive. Featuring Dynamic SAFety suspension (DSA), ABS, EBD and EBA all fitted as standard, together with the availability of ESP and TC across the range, the chassis spec reads like an A-Z of active safety. You can read more about what they do on the opposite page. Suffice to say that they're designed to give you greater peace of mind – whatever the road conditions.



## Powerful and efficient. Responsive and clean.

Meriva's engines pack plenty of punch, matched with low fuel consumption and low service requirements too. The range extends to three advanced petrol engines and two super-efficient common rail turbo diesels.



**Common rail diesels.** Meriva is available with two advanced, common rail, turbo diesel engines. The 1.3CDTi 16v 75PS unit and more powerful 100PS 1.7CDTi 16v engine are designed to offer good flexibility, tight emissions control and low running costs.



**Choice of transmissions.** Meriva can be specified with either a slick, five-speed manual gearbox or, on some models, Vauxhall's innovative Easytronic transmission. The ratios on five-speed manual versions have been specifically chosen to optimise flexibility and promote ease of driving.

**Petrol engines.** Meriva is available with a choice of three advanced petrol engines – highly economical 1.4i 16v and 1.6i 16v Twinport units plus a powerful 1.8i 16v. The Twinport variable induction system ensures lively power delivery with high fuel economy and low emissions.



**Easytronic.** Choose the optional Easytronic transmission and you'll get a five-speed manual gearbox with a fully automatic mode. In manual mode, you simply push the lever forward or back to shift gears up or down. The fascia display tells you what gear you're in – 1 to 5, N for Neutral or A for Auto. Switch to fully automatic mode and it has many of the features of a regular automatic, including a kickdown function. There's no clutch pedal so you can drive it on an automatic-only driving licence.





**▶ Audio and Sat Nav.** If quality sounds are high on your agenda, you won't be disappointed by Meriva. Choose Life or Club and you get a quality radio/CD player with steering wheel controls as standard. Select Design and you're also treated to our ingenious rear seat Twin Audio® system and a CD player capable of playing MP3 CD files. Optional infotainment systems include our new auxiliary-in socket so you can play tracks directly from your personal MP3 player, a CD autochanger and the very best in satellite navigation too. Turn to page 48/49 for more feature information and availability details.



**▲ Welcome lighting and door-to-door illumination.** Meriva's front, rear and interior lights are activated when the car is unlocked using the remote control unit; they go out when the engine is started, or when the car is locked. On Club and Design models simply flick the main beam headlight stalk upon leaving the car and the dipped headlights and rear lights stay on for 30 seconds, giving you time to make your way from the vehicle in an unlit driveway or car park.



**▼ Air-con and ECC.** Air conditioning provides chilled air on hot days, faster demisting on damp days and a more pleasant atmosphere throughout the year. Move up to Electronic Climate Control (ECC) for a more consistent control of the interior temperature.



**◀ Bluetooth® technology.** Meriva Club models can be specified with the latest mobile phone technology, operated via the car's steering wheel mounted audio controls. Further explanation can be found in the Equipment section on page 49.

**▲ Perfect seating position.** With a six-way adjustable driver's seat – including height adjustment – and a tiltable steering column on Design models, it's easy to find the perfect seating position. Club and Design models also feature a folding front armrest.







## How do you like to drive?

Meriva puts the driver firmly in control. To begin with, the six-way adjustable driver's seat – including height adjustment – plus a tiltable steering column (standard on Design, optional at extra cost on Life and Club) ensure the perfect driving position. And the driver environment is packed with clever ideas to make driving easier and more enjoyable.



◀ ▼ **Twin Audio®**. Meriva's independent rear seat Twin Audio® system – standard on Design, optional on Club – comes with a single headphone set and separate rear controls. There's an on/off switch, the ability to change between CD and radio tuner and a scan function. So front and rear passengers can listen to the radio or a CD totally independently and at the same time. It even mutes the rear speakers when in use. Up to two headphone sets can be accommodated with independent headphone controls for each. Additional headphone sets and alternative earhook headphones (shown left) are available as accessories.



## Enjoy the luxury of comfort and convenience.

Meriva is a great car to travel in because it's just as comfortable in the back as in the front. And there are many clever features designed to make every journey a pleasure.



◀ ▶ ◂ ▸ **Clever storage solutions.** Meriva is packed with practical storage ideas. Depending on which model you choose, you'll find features like a stowage net and underseat storage tray for the front passenger, a driver's sunglasses holder, coin and drinks holders, luggage hooks and more.



◂ ▸ **Underfloor storage.** All Vauxhall cars will keep your luggage under cover and out of sight, but the Meriva luggage compartment also features two side storage bins and an underfloor storage area, with three compartments including a special one designed for a warning triangle (not supplied).



◂ ▸ **Fold-out tray tables.** Meriva's practical tray tables, with their integrated drinks holders – standard on Design models – provide a handy surface for a variety of uses. They also come with net pockets for both front seat backs – perfect for magazines and other rear passenger belongings.

◂ ▸ **Fold-flat front passenger seat.** Select the optional fold-flat front passenger seat and you can make room for even more luggage – enough for loads of up to 2400mm in length with both front and rear nearside seats folded. The seat back even doubles as a handy table top – ideal for those impromptu picnic stops. Turn to page 54 for more details of Meriva's loadspace dimensions and luggage capacities.







Decide who you are.

And choose your Meriva.

No two families are identical. And no two Meriva drivers will want exactly the same blend of model, engine and equipment. That's why we've made Meriva choice as flexible as possible. With four feature-packed trim levels – plus the sensational Meriva VXR – five power units and a huge array of options, option packs and accessories, Meriva offers a model to suit all families – and all budgets.

Expression is our entry model – superb value and remarkably well equipped. Life takes this successful recipe and adds just that little bit more. Club is our upwardly mobile model – clearly aspirational in its outlook. While Design models more than live up to their name – capturing everything that's great about Meriva with an added injection of style.

**EXPRESSION**

**Standard features include:**

- Anti-lock Braking System (ABS)
- FlexSpace® flexible rear seats
- Twin front airbags
- Three rear seat head restraints and lap and diagonal rear seatbelts
- Engine deadlock immobiliser
- Remote control central deadlocking
- CC 20 stereo radio/cassette player
- Welcome lighting
- ISOFIX child seat fixings on outer rear seats
- Dark-style tail lights

Engine availability	Insurance groups (ABI)	
	20	50
1.4i 16v Twinport	3E	9E
1.3CDTi 16v	3E	8E



*Please note: Insurance groups relate to both the previous 20 group rating and the new 50 group rating.*



## LIFE

### Standard features include:

- Anti-lock Braking System (ABS)
- FlexSpace® flexible rear seats
- Twin front airbags
- Three rear seat head restraints and lap and diagonal rear seatbelts
- Engine deadlock immobiliser
- Remote control central deadlocking
- Welcome lighting
- ISOFIX child seat fixings on outer rear seats
- Dark-style tail lights

### Additional features over and above Expression model:

- Electrically operated front windows with safety autoreverse and one-touch facility
- CD 30 stereo radio/CD player
- Steering wheel mounted audio controls

Engine availability	Insurance groups (ABI)	
	20	50
1.4i 16v Twinport	4E	9E
1.6i 16v Twinport	4E	12E
1.6i 16v Twinport Easytronic	4E	12E
1.3CDTi 16v	3E	8E
1.7CDTi 16v	5E	14E

Please note: Insurance groups relate to both the previous 20 group rating and the new 50 group rating.

Two-coat pearlescent paint is optional at extra cost.



**CLUB****Additional features over and above Life model:**

- Air conditioning
- Body-colour door handles and side-protection mouldings
- Front seat folding centre armrest
- Body-colour electrically adjustable/heated door mirrors
- Front passenger's underseat storage tray
- Front and rear reading lights
- Door-to-door illumination

Engine availability	Insurance groups (ABI)	
	20	50
1.4i 16v Twinport	5E	10E
1.6i 16v Twinport	5E	12E
1.6i 16v Twinport Easytronic	5E	12E
1.8i 16v	6E	16E
1.8i 16v Easytronic	6E	16E
1.3CDTi 16v	4E	8E
1.7CDTi 16v	6E	15E

Please note: Insurance groups relate to both the previous 20 group rating and the new 50 group rating.

Two-coat pearlescent paint is optional at extra cost.

**Optional Club Plus Pack:**

- 15-inch Structure wheels
- Front fog lights
- Leather-covered steering wheel
- Dark-tinted Solar Protect® glass (excludes windscreen and front door windows)
- Cruise control
- Tilttable steering column

## DESIGN

### Additional features over and above Club model:

- Tilttable steering column
- Leather-covered steering wheel
- Cruise control
- Black foil on door pillars
- Dark-tinted Solar Protect® glass
- Electrically operated rear windows
- Twin electrically operated sunroofs
- Front fog lights with chrome-effect surrounds
- CD 30 stereo radio/CD with MP3 format
- Rear seat Twin Audio®
- Map pockets and aviation-style folding trays on front seat backs
- Alloy-effect centre console
- 15-inch Structure wheels

### Additional features for Design models with Exterior Pack:

- 17-inch five-spoke alloy wheels
- VXR Styling Pack One\*

Engine availability	Insurance groups (ABI)	
	20	50
1.4i 16v Twinport	5E	12E
1.6i 16v Twinport	5E	12E
1.6i 16v Twinport Easytronic	5E	12E
1.8i 16v	6E	15E
1.8i 16v Easytronic	6E	15E
1.7CDTi 16v	6E	15E

Please note: Insurance groups relate to both the previous 20 group rating and the new 50 group rating.

Two-coat metallic paint is optional at extra cost.



### Optional Design Plus Pack:

- Electronic Climate Control (ECC) incorporating air conditioning
- Solar Reflect® windscreen
- Electro-chromatic anti-dazzle rear-view mirror
- Indirect night lighting

\*See pages 31 and 48 for full details.



## Options and accessories

Vauxhall options and accessories are all about choice – selecting your new car, then personalising it to suit yourself. There's a choice of factory-fitted options and a huge range of retailer-fit accessories. You can also choose styling products from the VXR range as well as auto design specialist Irmscher International. You'll find further information on the following pages or just ask your Vauxhall retailer for more details.



## VXR Styling

Inspired by the hugely successful VXRRacing team, Vauxhall VXR styling products come with all the same experience, knowledge, and passion for style and performance. They put the accent firmly on quality and exclusivity, with a winning edge. And they add flair, personality and excitement to every Meriva model. VXR styling products are available as factory-fit option packs or accessories fitted by your Vauxhall retailer. Please refer to the Vauxhall Car and Accessory Price Guide for availability details of the full Vauxhall VXR styling range.

◀ ▶ **VXR Styling Pack One.** Breathe some extra style into your Meriva with a front lower spoiler, side sills, rear roof spoiler (see below) and rear skirt. All of these items are also available separately as retailer-fit accessories. Design model illustrated also features optional 16-inch alloy wheels available at extra cost.



## irmscher Styling

Developed in conjunction with auto design specialists Irmischer International, Meriva styling accessories perfectly complement the vehicle's lines, as well as being manufactured to the same exacting standards as the car itself. For availability details of these features please refer to the Vauxhall Car and Accessory Price Guide.



◀ **Irmischer Styling Pack.** Treat your Meriva to the Irmischer Styling Pack which consists of body colour front lower spoiler, side sills, rear roof spoiler and rear lower skirt. Vehicle illustrated also features sports silencer with twin rectangular tailpipes and 17-inch Delta alloy wheels.



◀ ▶ **Irmischer alloy wheels.** With a huge range of styles – including Signa (left), Stila (right) and Delta (on vehicles) – and sizes to choose from, you're sure to find one to suit your chosen look and budget. Don't forget to ask about accessory wheel locking kits too.



Available individually or in special packs at great prices, Meriva options can make life better in so many ways. Alloy wheels, air conditioning, satellite navigation – there's a huge range to choose from. Simply make your choice when you order your new car and it'll be fitted at the factory for you. You'll find further information on availability in the Equipment section. Or you can ask your Vauxhall retailer.





**▶ Protection Pack:**

- Electronic Stability Programme (ESP)
- Traction control
- Full-size curtain airbags
- Front seat side-impact airbags
- Active-safety front seat head restraints
- Front seat occupancy detection
- ISOFIX child seat fittings



**▶ Bluetooth® technology.\*** Meriva Club models can be specified with the latest mobile phone technology, operated via the car's steering wheel mounted audio controls. Fully integrated into the car's audio system, it is easy to use, with both voice activation and the latest Bluetooth® wireless connectivity. Further explanation can be found in the Equipment section on page 49.

*\*Phone and cradle not included.*

**INDIVIDUAL OPTIONS INCLUDE:**

- Tiltable steering column
- Air conditioning
- Halogen adaptive forward lighting
- CD 70 stereo radio/CD with MP3 format/auxiliary-in socket/satellite navigation with monochromatic graphic information display
- CDC 40 stereo radio/CD autochanger with MP3 format and monochromatic graphic information display
- CD 30 MP3 stereo radio/CD with MP3 format/auxiliary-in socket
- Rear seat Twin Audio® system with single headset (deletes auxiliary-in socket)



**▶ Fold-flat front passenger seat.**

Select the optional fold-flat front passenger seat and you can stretch the maximum interior load length from 1568mm to an extraordinary 2400mm. The folded seat back can even double as a handy table top – ideal for those impromptu picnic stops.

**▶ Dual sunroof.** Meriva's always been about treating all passengers the same. Choose the optional electrically operated slide/tilt glass front sunroof and tiltable glass rear sunroof and both front and rear seat passengers will get their fair share of the sun.



**▶ Alloy wheels.** These optional 16-inch alloy wheels add an extra touch of style to Design models.

Vauxhall accessories are the right choice for your Meriva. Whatever you're into, there's certain to be a Vauxhall accessory with your name on it, all fitted by trained Vauxhall professionals. We've only featured a small selection of what's available here. The Vauxhall Car Accessory Brochure and Car and Accessory Price Guide give further details or check out our website at [www.vauxhall-accessories.com](http://www.vauxhall-accessories.com)



◀ **Premium bicycle carrier.** With a moulded profile that holds the bicycle upright, leaving both hands free to secure it, this innovative carrier fits bikes with a frame tube of 20-80mm diameter. Two carriers may be fitted onto the base carrier, so remember to specify left or right hand fitting.



▲ **Child seats.** Vauxhall offers a range of child seats, ergonomically styled for comfort and safety. The Baby-Safe (for babies from birth to 13kg), and Kid (15-36kg) seats are fixed with a standard lap and diagonal seatbelt, while the Duo ISOFIX (9-18kg) can also be attached using the ISOFIX child seat restraint fittings, which are standard on the outer rear seats of all Meriva models. The rigid ISOFIX anchoring mechanism virtually eliminates the dangers of incorrect child seat installation. For further information on our complete range of child seats, please ask for a copy of the Vauxhall Accessories Child Seat brochure available from your Vauxhall retailer.



◀ **Tow bar and 12N electrics.** Tow in confidence with the detachable Meriva tow bar. It won't get in the way when you don't need it, but it's easy to mount when you do. And naturally, it is tested to comply with top European standards. Meriva accessory towing mirrors are also available.

**VAUXHALL ACCESSORY PACKS**

Vauxhall accessory packs bring together a selection of essential accessories at great prices, helping you to protect your car and equipping you for roadside emergencies.

▶ **Dog guard\***. Specially designed for Meriva, our heavy-duty steel dog guard will help keep your dog secure in the rear of the car and protects the driver and passenger in the event of sudden braking or emergency manoeuvres.

*\*Only fits directly behind front seats with rear seat folded flat.*



◀ **Rear parking distance sensors.** This invaluable parking aid is mounted within the Meriva rear number plate area. Activated automatically when reverse gear is selected, it beeps as you approach an obstruction changing to a continuous tone when it's approximately 300mm away.



◀ ▶ **Protection Pack.**

- Velour mats
- Mudflaps
- Cargo liner

▶ **Base carrier and roof box.** The Vauxhall roof rack system begins with a base carrier, comprising two T-track roof bars which support a wide range of attachments. These include a high capacity roof box which is lockable and easy to fit.



▶ **Travel Pack.**

- First aid kit
- Warning triangle
- Hi-visibility vest





# MERIVA VXR

**This is extra-sensory stimulation. Cars with soul and power to make you feel alive, electrified and inspired. A range of driver-focused, performance machines for the road, born on the track.**







- > Unique VXR body styling
- > 180PS 1.6i 16v Turbo
- > 17-inch six-spoke alloy wheels
- > VXR Recaro sports seats



DISCOVER 7.9<sup>SEC</sup>  
0-60MPH

VXR takes all the experience, knowledge and passion gained from over 110 BTCC wins and crystallises it into a range of high performance road cars. Clinching the 2007 Dunlop MSA British Touring Car Championship (BTCC) driver and manufacturer honours in the final race of the season, Vauxhall became the most successful manufacturer in the modern era, accumulating seven Drivers Championships, seven Manufacturers Championships and four team titles along the way.

*For more information on the Meriva VXR please ask your Vauxhall retailer for a copy of the latest VXR range brochure.*

“POINTLESS? ON THE CONTRARY, I FOUND THE JUXTAPOSITION OF MPV LOOKS AND HOT-HATCHBACK DYNAMICS RIOTOUSLY ENTERTAINING. IT MIGHT BE AN UNLIKELY IDEA, BUT IT’S A HECK OF A GOOD ONE.”

*THE INDEPENDENT - FEBRUARY 2007*







## MERIVA VXR.

Who said serious performance and family-style practicality don't mix? Quite simply, this is the clever and versatile MPV for anyone who loves driving. Check out the unique VXR styling. Lowered and uprated sports suspension. Not to mention the sensational, turbocharged 180PS 1.6i 16v engine. Truth is, you won't find a more rapid car in this class. But then, with Meriva VXR, that's only half the story.

▶ Flame Red – solid



▶ Star Silver – metallic



▶ Royal Blue – solid



▶ Silver Lightning – metallic



▶ Glacier White – solid



▶ Metro Blue – metallic



▶ Sunny Melon – solid



▶ Lancelot – metallic





Meriva's colour and trim combinations have been carefully selected to complement each other, while reflecting the individual status of each model in the range.

*Due to the limitations of the printing process the colours reproduced may vary slightly from the actual paint colour or trim material. As a result they should be used as a guide only. Your Vauxhall retailer has a comprehensive display of all our paint samples and trim swatches.*

▶ Air Blue – pearlescent



▶ Ultra Blue – pearlescent



▶ Black Sapphire – pearlescent



▶ Steel Blue – pearlescent





Interior trims

▼ Punch, Charcoal



▼ Punch, Blue

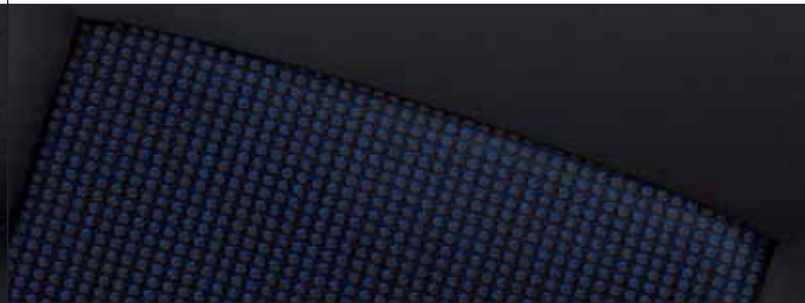

▼ Punch, Red

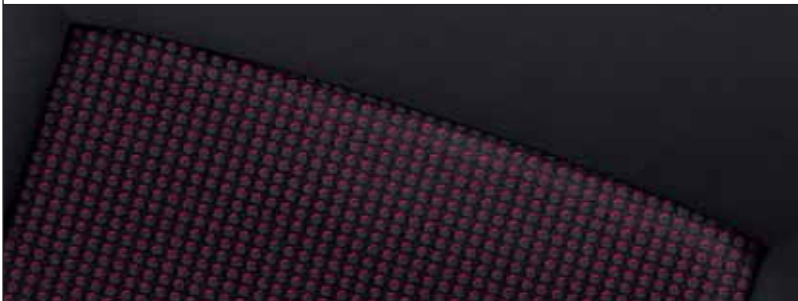

▼ Fuse, Charcoal



Exterior colours

Model, trim name and trim colour

	Expression Punch cloth	Life Punch cloth	Club Punch 'Classic' cloth	Design Fuse cloth
<b>Solid</b>				
Flame Red	Charcoal	Charcoal	Charcoal or Red	Charcoal
Royal Blue	Charcoal	Charcoal	Charcoal	Charcoal
Glacier White	Charcoal	-	-	-
Sunny Melon	Charcoal	Charcoal	Charcoal	-
<b>Two-coat metallic*</b>				
Star Silver	-	Charcoal	Charcoal, Red or Blue	Charcoal
Silver Lightning	-	Charcoal	Charcoal or Blue	Charcoal
Metro Blue	-	Charcoal	Charcoal or Blue	Charcoal
Lancelot	-	Charcoal	Charcoal or Blue	Charcoal
<b>Two-coat pearlescent*</b>				
Ultra Blue	-	Charcoal	Charcoal or Blue	Charcoal
Steel Blue	-	Charcoal	Charcoal	Charcoal
Air Blue	-	Charcoal	Charcoal or Blue	Charcoal
Black Sapphire	-	Charcoal	Charcoal, Red or Blue	Charcoal

- = Exterior colour listed is not available on this model.

\* = Available at extra cost.

## Contents

### Equipment

Safety Security	44
Heating and ventilation Facia, instruments and controls Seating	45
Additional interior features Mechanical	46
Wheels and tyres Exterior protection and styling Exterior and convenience features	47
Option packs Audio, navigation and communication	48
<b>Technical data</b>	
Engines	50
Performance, fuel economy and emissions Weights and towing data	51
Vauxhall Assistance and warranties, transmission, steering, suspension and brakes	52
Features explained	53
Exterior dimensions Luggage capacities	54
Seating configurations	55

## Safety

**Standard features** • Driver's airbag • Front passenger's airbag • Pedal release system – Reduces potential injury to the driver's legs and feet during a severe frontal impact • Laminated windscreen • Burst-proof door locks and anti-jam door design • Reinforced passenger safety cell • Side-impact protection beams • Fuel tank located ahead of rear axle

• ISOFIX child seat restraint system for outer rear seats (does not include child seat) • Child-proof locks on rear doors

• Anti-lock Braking System (ABS) with Electronic Brakeforce Distribution (EBD) • Emergency Brake Assist (EBA) – See **D1** on page 53

• Height-adjustable front seat head restraints • Height-adjustable front seatbelts • Pyrotechnic front body-lock seatbelt pretensioner system – Tightens the seatbelt during the early stages of a frontal impact • Front seatbelt force limiters – Reduce potential upper body injuries during a frontal impact • Three inertia-reel lap and diagonal rear seatbelts • Three adjustable rear seat head restraints • Anti-submarining ramps in all seats – Help prevent occupants sliding underneath the lap belt during a collision • Reinforced rear seat back – Helps prevent heavy items entering the passenger compartment

<b>Additional features</b>	Exp.	Life	Club	Design	Design XP
Front seat side-impact airbags	<input type="checkbox"/>	<input type="checkbox"/>	<input type="checkbox"/>	<input type="checkbox"/>	<input type="checkbox"/>
Full-size curtain airbags	<input type="checkbox"/>	<input type="checkbox"/>	<input type="checkbox"/>	<input type="checkbox"/>	<input type="checkbox"/>
Automatic seat occupancy detection for front passenger's airbags	<input type="checkbox"/>	<input type="checkbox"/>	<input type="checkbox"/>	<input type="checkbox"/>	<input type="checkbox"/>
ISOFIX child seat restraint system for front passenger's seat (does not include child seat)	<input type="checkbox"/>	<input type="checkbox"/>	<input type="checkbox"/>	<input type="checkbox"/>	<input type="checkbox"/>
Active-safety front seat head restraints (height-adjustable)	<input type="checkbox"/>	<input type="checkbox"/>	<input type="checkbox"/>	<input type="checkbox"/>	<input type="checkbox"/>
Electronic Stability Programme (ESP) – see <b>D2</b> on page 53	<input type="checkbox"/>	<input type="checkbox"/>	<input type="checkbox"/>	<input type="checkbox"/>	<input type="checkbox"/>
Electronic traction control with two-way intervention	<input type="checkbox"/>	<input type="checkbox"/>	<input type="checkbox"/>	<input type="checkbox"/>	<input type="checkbox"/>

## Security

**Standard features** • Remote control two-stage central locking (doors, tailgate and fuel flap) with security deadlocks • Freewheeling door and ignition locks • Electronic theft protection system for audio equipment and remote display • Electronic engine deadlock immobiliser • 'Key left in ignition' audible warning • Visible Vehicle Identification Number (VIN)

<b>Additional feature</b>	Exp.	Life	Club	Design	Design XP
Door-to-door illumination			●	●	●



## Heating and ventilation

**Standard features** • Air blend heater with four-speed fan and illuminated controls • Interior pollen filter • Side window demist vents • Four adjustable heating and ventilation outlets on fascia • Rear passenger compartment heating outlets on centre console

### Additional features

	Exp.	Life	Club	Design	Design XP
Interior odour-reducing activated charcoal filter	●	● <sup>1</sup>			
Air conditioning and air recirculation facility		○	●	●	●
Electronic Climate Control (ECC) and Solar Reflect® windscreen				□	□

## Facia, instruments and controls

**Standard features** • Rev counter • Electronically controlled coolant temperature gauge and fuel gauge • Trip odometer • Low fuel level warning light • Service-due indicator • Handbrake-on warning light • Three-spoke steering wheel • Instrument panel light dimmer • Illuminated glovebox with lid • 12-volt electrical accessory socket in front and rear centre consoles • Multi-function display panel showing time, date, audio information and outside air temperature (with ice warning function) • Digital clock with automatic RDS time adjustment

### Additional features

	Exp.	Life	Club	Design	Design XP
Tiltable steering column		○	○ <sup>2</sup>	●	●
Leather-covered steering wheel			□	●	●
Cruise control			□	●	●

## Seating and upholstery

**Standard features** • Reclining front seats • Driver's seat height adjuster • FlexSpace® rear seating – Provides an innovative solution to varying passenger and luggage carrying requirements • 40/20/40 split-folding rear seat • Outer rear seats independently adjustable for reach and rake

### Additional features

	Exp.	Life	Club	Design	Design XP
Punch cloth seat trim	●	●	●		
Fuse cloth seat trim				●	●
Front passenger's seat with fold-flat facility			○	○	○
Front seat folding centre armrest			●	●	●
Map pockets and aviation-style folding trays on front seat backs				●	●
Front passenger's underseat storage tray			●	●	●



Electronic Climate Control (ECC).



Multi-function display panel.

- = Standard equipment
- = Optional at extra cost.
- = Only available as part of an extra-cost option pack (see page 48 for details).

Exp. = Expression  
XP = .Design with Exterior Pack models.

1 = Activated charcoal filter is deleted if optional air conditioning is specified.

2 = Also available as part of an extra-cost option pack.



Driver's sunglasses holder.



Storage compartments under luggage compartment floor.



Front passenger's storage net on lower centre console.

## Additional interior features

**Standard features** • Front door pockets with drinks holders • Storage box on driver's side lower fascia • Drinks holders in centre console • Coin holder in centre console • Three tiltable passenger assist handles, rear with integral coat hooks • Dipping rear-view mirror • Twin sunvisors with mirror and document pocket • Fade up/fade down front courtesy light operated by front door switches • Hinged and folding luggage compartment cover • Illuminated luggage area • Two interior tailgate handles • Four load restraint lashing eyes • Storage compartments under luggage compartment floor • Storage bins in sides of luggage compartment • Load area sill protection • Chrome-effect door handles, handbrake button and gear knob trim

<b>Additional features</b>	Exp.	Life	Club	Design	Design XP
Maze charcoal trim inserts on fascia and front doors			●		
Maze chrome inserts on fascia and front doors				●	●
Dark metallic-effect centre console	●	●	●		
Alloy-effect centre console				●	●
Chrome-effect trim on instrument surrounds			●	●	●
Driver's sunglasses holder			●		
Front reading lights			●	●	●
Rear reading lights			●	●	●
Indirect night lighting and electro-chromatic anti-dazzle rear-view mirror				□	□
Front passenger's storage net on lower centre console			●	●	●
Two luggage hooks on rear seat backs			●	●	●
Load-restraining floor net in luggage area			●	●	●

## Mechanical

**Standard features** • Front-wheel drive • Five-speed manual gearbox • Speed-sensitive electric power-assisted steering • Gas-pressure dampers • Front anti-roll bar

<b>Additional feature</b>	Exp.	Life	Club	Design	Design XP
Easytronic five-speed transmission with sequential manual gearshift or automatic mode (1.6i 16v/1.8i 16v models only)		○	○	○	○

## Wheels and tyres

Features	Exp.	Life	Club	Design	Design XP
Flush wheel covers	●	●	●		
15-inch steel wheels with 185/60 R 15 low profile tyres	●	● <sup>3</sup>	● <sup>3</sup>		
15-inch Structure wheels with 185/60 R 15 low profile tyres			□ <sup>4</sup>	●	
16-inch alloy wheels with 205/50 R 16 ultra-low profile tyres and locking wheel bolts				○ <sup>3</sup>	
17-inch alloy wheels with 205/45 R 17 ultra-low profile tyres and locking wheel bolts					● <sup>3</sup>
Emergency tyre inflation kit (in lieu of spare wheel)	●	●	●	●	●
15-inch steel spare wheel/tyre (in lieu of emergency tyre inflation kit)	○	○	○	○	○ <sup>5</sup>



15-inch Structure wheel.

## Exterior protection and styling

Features	Exp.	Life	Club	Design	Design XP
Chrome-effect moulding on tailgate	●	●	●	●	●
Body-colour bumpers	●	●	●	●	●
Black body side-protection mouldings	●	●			
Body-colour side-protection mouldings, door handles and tailgate handle			●	●	●
Body-colour door mirrors			●	●	●
Black foil on door pillars (except with Black Sapphire paint)			○ <sup>6</sup>	●	●



Design with Exterior Pack 17-inch wheel.

## Exterior and convenience features

**Standard features** • Green-tinted glass • Two-speed symmetrical overlap windscreen wipers with variable intermittent wipe • Heated rear window with intermittent wash/wipe • Automatic activation of rear wiper when windscreen wipers are operating and reverse gear is selected • Foldable door mirrors • Lights-on audible warning • Halogen headlights • Welcome lighting – Switches headlights, tail lights and interior lights on by remote control via key fob • Electric headlight beam levelling • High-level LED centre brake light • Dark-style tail lights

Additional features	Exp.	Life	Club	Design	Design XP
Dark-tinted Solar Protect® glass (excludes windscreen and front door windows) <sup>7</sup>			□	●	●
Electrically operated front windows with safety autoreverse and one-touch facility		●	●	●	●
Electrically operated rear windows with safety autoreverse and one-touch facility				●	●
Twin electrically adjustable/heated door mirrors (wide-angle on driver's side)			●	●	●
Electrically operated slide/tilt glass front sunroof and tiltable glass rear sunroof				●	●
Adaptive Forward Lighting (AFL) – halogen – see <b>D3</b> on page 53			○	○	○
Front fog lights			□	● <sup>8</sup>	● <sup>8</sup>
Two-coat metallic or pearlescent paint		○	○	○	○

● = Standard equipment.  
 ○ = Optional at extra cost.  
 □ = Only available as part of an extra-cost option pack (see page 48 for details).  
 Exp. = Expression.  
 XP = Design with Exterior Pack models.

3 = 1.7CDTI 1.6v models feature five-bolt wheel attachment, all others are four-bolt.

4 = All models feature five-bolt wheel attachment.

5 = Speed restriction applies.

6 = Fitted in conjunction with optional Plus Pack. Not available separately.

7 = Includes black foil on door pillars except on models with optional Black Sapphire two-coat pearlescent paint.

8 = Includes chrome-effect surround.





Cruise control – part of the Club Plus Pack.



CD 30 MP3 format audio unit.

- = Standard equipment.
- = Optional at extra cost.
- Exp. = Expression.
- XP = Design with Exterior Pack models.

- 7 = Includes black foil on door pillars except on models with optional Black Sapphire two-coat pearlescent paint.
- 9 = Does not include auxiliary-in socket.
- 10 = Only available in conjunction with optional audio units. Deletes auxiliary-in socket from CD 30 MP3. Not available in conjunction with mobile phone system with Bluetooth®.
- 11 = Not available in conjunction with rear seat Twin Audio®.

## Option packs

	Exp.	Life	Club	Design	Design XP
<b>VXR Styling Pack One</b> ● Body-colour front lower spoiler/side sills/rear lower skirt/rear roof spoiler			○	○	●
<b>Protection Pack</b> ● Electronic Stability Programme (ESP) – see <b>D2</b> on page 53 ● Electronic traction control with two-way intervention ● Full-size curtain airbags ● Front seat side-impact airbags ● Active-safety front seat head restraints ● Automatic seat occupancy detection for front passenger's airbags ● ISOFIX child seat restraint system for front passenger's seat (does not include child seat)	○	○	○	○	○
<b>Plus Pack</b> ● 15-inch Structure wheels ● Front fog lights ● Leather-covered steering wheel ● Cruise control ● Tilttable steering column ● Dark-tinted Solar Protect® glass (excludes windscreen and front door windows) <sup>7</sup>			○		
<b>Plus Pack</b> ● Electronic Climate Control (ECC) incorporating air conditioning ● Solar Reflect® windscreen ● Electro-chromatic anti-dazzle rear-view mirror ● Indirect night lighting				○	○

## Audio, navigation and communication

Features	Exp.	Life	Club	Design	Design XP
<b>CC 20 stereo radio/cassette player</b> ● AM/FM stereo radio with 24 station presets ● RDS with Traffic Programme ● Cassette player ● Remote display ● 20 watts per channel output ● 6 speakers	●				
<b>CD 30 stereo radio/CD player</b> ● AM/FM stereo radio with 24 station presets ● RDS with Traffic Programme ● CD player ● Remote display ● 20 watts per channel output ● 6 speakers		●	●		
<b>CD 30 MP3 stereo radio/CD player with MP3 format</b> ● AM/FM stereo radio with 24 station presets ● RDS with Traffic Programme ● CD player with MP3 format ● Auxiliary-in socket ● Remote display ● 20 watts per channel output ● 6 speakers		○	○	● <sup>9</sup>	● <sup>9</sup>
<b>CDC 40 stereo radio/CD autochanger</b> ● AM/FM stereo radio with 36 station presets ● RDS with Traffic Programme ● Integral six-disc CD autochanger with MP3 format ● Remote monochromatic graphic information display ● 20 watts per channel output ● 8 speakers			○	○	○
<b>CD 70 stereo radio/CD player with MP3 format/satellite navigation</b> ● AM/FM stereo radio with 24 station presets ● RDS with Traffic Programme ● CD player with MP3 format ● Satellite navigation system ● Auxiliary-in socket ● Remote monochromatic graphic information display ● 20 watts per channel output ● 6 speakers			○	○	○

## Audio, navigation and communication (continued)

Features	Exp.	Life	Club	Design	Design XP
Steering wheel mounted audio controls		●	●	●	●
Rear seat Twin Audio® with single headset			○ <sup>10</sup>	●	●
Mobile phone system with Bluetooth® (does not include phone or phone-specific cradle) and graphic information display			○ <sup>11</sup>		

### Satellite navigation

Vauxhall's CD-ROM-driven satellite navigation system is very simple to operate, using a range of menu-driven options which are easily accessed via the steering wheel mounted audio controls.

The CD-ROM supplied with the system covers all major link roads and streets in towns and cities across mainland Britain.

Clearly spoken instructions indicate the route you need to take or the lane you need to be in, while directional pictograms, clearly shown on the special monochromatic graphic information display, back-up the spoken commands.

The CD 70 also features Traffic Message Channel (TMC), a specific application of RDS used for broadcasting real-time traffic information, delivered either visually or verbally.

### Standard features

- Automatic re-routing on request
- CD-ROMs available for all major European countries
- CD-ROM may be replaced by audio CD after route is selected
- Display of estimated time remaining and distance to destination
- Exact location of vehicle using the GPS (Global Positioning System) and speed sensor
- Choice of four different route types
- Store up to 100 personal destinations
- Last 10 destinations stored automatically

### Auxiliary-in socket

The auxiliary-in socket allows you to connect your portable MP3 music player directly into the car's audio system. All you need is your music player and a suitable connecting lead and you can listen to all your favourite tunes through your car's speaker system. Using your MP3 music player in the car couldn't be easier – use it to select the music, as you would normally do, while controlling the volume via the car's regular volume controls.

### MP3 CD player

An MP3 is a compressed sound or music file which, due to its small size, takes up less space on a compact disc, which means that more tracks can be recorded onto a CD. It's possible to fit almost 10 hours of music onto one CD, and, in a way, turns a single-disc CD/MP3 player into a multi-disc autochanger. Providing you have access to a compatible computer to create the MP3 tracks, you can compress your CD collection and create your own compilations – and you won't have to drive around with all your original CDs in the car.

### Mobile phone system with Bluetooth®

Available on Meriva Club models only, Vauxhall's factory-fit dual-band mobile phone system has been considerably enhanced. Now fully integrated into the audio and communication system, it also features voice control and will connect wirelessly to phones with Bluetooth® technology.

All the required information is displayed on the multi-function display when a mobile phone is in use, while the menus are easily navigated by either the steering wheel audio controls or the multi-function button on the radio. Certain functions can also be controlled by voice activation.

Mounted on the centre console, the phone system base unit can be fitted with phone-specific cradles (available as accessories) for many different mobile phones. A list of compatible cradles is featured in the Vauxhall Car and Accessory Price Guide.

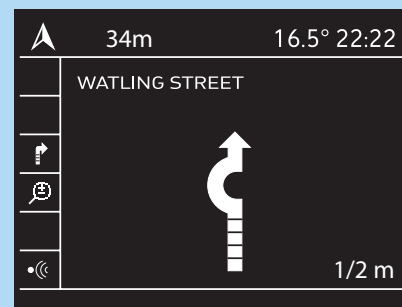

Satellite navigation.



Mobile phone system with Bluetooth®.



125PS

1.8i 16v engine gives punchy performance

### Petrol engines

	1.4i 16v Twinport ECOTEC-4	1.6i 16v Twinport ECOTEC-4	1.8i 16v ECOTEC-4
Capacity	1364cc	1598cc	1796cc
Maximum power	90PS (66kW) @ 5600rpm	105PS (77kW) @ 6000rpm	125PS (92kW) @ 6000rpm
Maximum torque	125Nm (92 lb.ft.) @ 4000rpm	150Nm (111 lb.ft.) @ 3900rpm	165Nm (122 lb.ft.) @ 4600rpm
Configuration	4 cylinders, 4 valves per cylinder, double overhead camshafts		
Fuel/induction system	Naturally aspirated with vacuum-controlled Twinport inlet ports Multi-point sequential fuel injection		Naturally aspirated Multi-point sequential fuel injection
Service interval	20,000 miles or 1 year (whichever occurs sooner)		
<b>Benefit in kind company car taxation - 2007/08 tax year*</b>			
Manual/Easytronic	17%	22%/21%	25%/24%

### Diesel engines

	1.3CDTi 16v ECOTEC-4	1.7CDTi 16v ECOTEC-4
Capacity	1248cc	1686cc
Maximum power	75PS (55kW) @ 4000rpm	100PS (74kW) @ 4400rpm
Maximum torque	170Nm (126 lb.ft.) @ 1750-2500rpm	240Nm (177 lb.ft.) @ 2300rpm
Configuration	4 cylinders, 4 valves per cylinder, double overhead camshafts	
Fuel/induction system	Turbocharger with intercooler. Common rail fuel injection	
Service interval	20,000 miles or 1 year (whichever occurs sooner)	
<b>Benefit in kind company car taxation - 2007/08 tax year*</b>		
Manual	18%	18%

\* = For details of 2008/09 tax year benefit in kind company car taxation rates please refer to the latest Vauxhall Car and Accessory Price Guide.



Twinport petrol engines.



Common rail turbo diesel engines.



## Performance, fuel economy and emissions

Model	Performance (manufacturer's figures)				Fuel economy mpg (litres/100km)			CO <sub>2</sub> emissions (g/km)
	Maximum speed (mph)	Acceleration (secs) 0-60mph	30-50mph (4th gear)	mph/1000rpm (5th gear)	Urban driving	Extra-urban driving	Combined figure	
<b>Manual</b>								
1.4i 16v	104	13.4	11.3	21.0	34.0 (8.3)	53.3 (5.3)	44.1 (6.4)	154
1.6i 16v	112	12.4	10.8	22.9	32.1 (8.8)	51.4 (5.5)	42.2 (6.7)	161
1.8i 16v	118	10.3	9.5	23.0	25.9 (10.9)	46.3 (6.1)	35.8 (7.9)	190
1.3CDTi 16v	98	16.6	8.7	22.9	45.6 (6.2)	65.7 (4.3)	56.5 (5.0)	135
1.7CDTi 16v	111	12.4	8.0	25.9	42.8 (6.6)	64.2 (4.4)	54.3 (5.2)	140
<b>Easytronic</b>								
1.6i 16v	112	13.4	-	24.4	31.7 (8.9)	52.3 (5.4)	42.2 (6.7)	161
1.8i 16v	118	11.3	-	23.0	26.4 (10.7)	46.3 (6.1)	36.2 (7.8)	187

The fuel consumption figures shown comply with EC directive 1999/100 to provide a realistic indication of fuel consumption by taking into account everyday driving conditions, such as cold starts, acceleration and braking. These figures take account of the vehicles kerbweight, ascertained in accordance with the above regulation. **Important:** the results given relate to the particular car tested. Variations in trim level and equipment may result in slightly higher fuel consumption and CO<sub>2</sub> emission levels than those quoted. Driving style, road and traffic conditions, vehicle mileage and standard of maintenance may also affect fuel consumption; therefore the results do not express or imply any guarantee of fuel consumption attainable.

## Weights and towing data kg

	Kerbweight (Gross vehicle weight)	Maximum towing weights
		Trailer with brakes (without brakes)
1.4i 16v Expression/Life	1255 (1785)	1000 (665)
1.4i 16v Life (air-con.)/Club/Design	1280 (1810)	1000 (665)
1.6i 16v Life	1300 (1830)	1200 (675)
1.6i 16v Life (air-con.)/Club/Design	1325 (1855)	1200 (675)
1.8i 16v Club/Design	1330 (1860)	1300 (675)
1.3CDTi 16v Expression/Life	1318 (1870)	1200 (675)
1.3CDTi 16v Life (air-con.)/Club	1343 (1895)	1200 (675)
1.7CDTi 16v Life	1380 (1910)	1300 (675)
1.7CDTi 16v Life (air-con.)/Club/Design	1405 (1935)	1000 (675)

**Gross vehicle weight** is the total permissible weight of the vehicle including passengers and their luggage. To determine total carrying capacity, deduct kerbweight from gross vehicle weight. Note that the figure obtained will include the weight of the driver, passengers and any optional equipment or accessories. The **maximum roof rack loading** should not exceed a total of 75kg. The **maximum towing weights** are based on the ability of the car, with two occupants of 75kg each, to restart on a 12% gradient, which is approximately 1 in 8.3, at sea level. At altitudes above 1500 metres, the engine output may drop with a corresponding reduction in towing capability. Any extra weight, such as luggage or additional passengers, should be deducted from the maximum towing weight. With a trailer fully loaded, **maximum noseweight** should not exceed 55kg (50kg on 1.8i 16v models). Always fit Vauxhall towing attachments and accessories available from your Vauxhall retailer. They are designed specifically for Vauxhall models and carry a 12-month guarantee.



**65.7mpg**  
1.3CDTi 16v engine provides exceptional economy



**1300kg**  
Maximum towing weight



**552kg**  
Maximum carrying capacity



## Vauxhall Assistance and warranties\*

- A one-year unlimited mileage manufacturer's warranty
- Second and third year no-fee customer option warranty up to 60,000 miles (from first registration)
- Vauxhall Assistance for 12 months from first registration
- Six years' body panel anti-perforation warranty

\* = Warranty is only available on vehicles sourced from Vauxhall Motors Ltd. Terms and conditions apply - please see your Vauxhall retailer for details.

## Optional transmission

### Five-speed Easytronic transmission:

Available at extra cost on 1.6i 16v and 1.8i 16v models. Easytronic transmission is a five-speed manual gearbox with a fully automatic mode. In manual mode, you simply push the lever forward or back to shift gears up or down sequentially. The fascia display tells you what gear you're in - 1 to 5, N for Neutral or A for Auto. Switch to fully automatic mode and it has many of the features of a regular automatic including a kickdown function. There's no clutch pedal so you can drive it on an automatic-only driving licence. Easytronic also comes with a winter mode, which selects second gear for standing starts in slippery conditions.

## Steering

- Rack and pinion
- Speed-sensitive electric power-assisted steering standard on all models
- Turning circle (kerb-to-kerb): 10.42m (34.2ft)
- Turns lock-to-lock: 3.8 (2.9 on Design with Exterior Pack models)

## Suspension

**Front:** Independent. MacPherson struts with coil springs and gas-pressure dampers. Anti-roll bar. Dynamic SAFETY (DSA) suspension - this aids stability when braking on surfaces with differing levels of grip on either side of the vehicle by increasing front wheel toe-in at the wheel with greater grip.

**Rear:** Torsion tube with compound links. Progressive-rate double conical mini-block springs and gas-pressure dampers.

## Brakes

- Anti-lock Braking System (ABS)
- Asbestos-free friction material
- Dual circuit, diagonally split, dual rate servo-assisted system
- Low brake fluid level warning light
- Plastic-coated brake pipes

### 1.4i 16v

Front ventilated discs: 260mm diameter  
Rear discs: 240mm diameter

### 1.6i 16v/1.8i 16v

Front ventilated discs: 280mm diameter  
Rear discs: 264mm diameter

### 1.3CDTi 16v/1.7CDTi 16v

Front ventilated discs: 280mm diameter  
Rear discs: 264mm diameter

## Body

- Aerodynamic drag co-efficient: Cd 0.31

## Fuel tank capacity

- 53 litres (11.7 gallons)

## Features explained

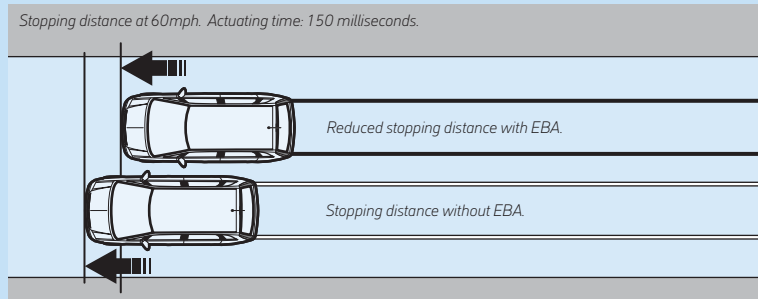

### D1. Emergency Brake Assist (EBA)

Emergency brake assist detects the urgency with which the brake pedal is pressed and rapidly increases the pressure to the maximum the system can provide, shortening stopping distances. It also enhances pedal feel.

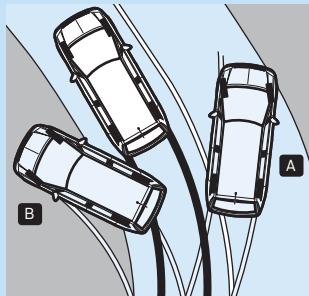

### D2. Electronic Stability Programme (ESP)

ESP helps the driver maintain full control of the vehicle during adverse or emergency conditions. ESP technology is designed to monitor both the front and rear of the car independently and compare their respective directions of travel with the driver's steering wheel input. If either the front **A** (understeer) or rear **B** (oversteer) of the vehicle begins to slide, ESP gently applies corrective braking to the appropriate individual road wheel, controlling the slide and maintaining safe progress.

**A** When a vehicle is understeering excessively, it displays an unwillingness to change direction as the outside front tyre has become overloaded and begun to slide. In this instance, ESP will apply a braking force to the inside rear wheel, slowing it down and increasing the vehicle's yaw angle to help the front wheels change direction.

**B** During the more unusual oversteering situation the vehicle's yaw angle is excessive due to the outside rear tyre having lost grip. Although countersteering is an effective solution, it is often difficult to judge how much opposite lock to apply. ESP, however, will apply the correct braking force to the outside front wheel, which will reduce the yaw angle and bring the vehicle back under control.

### D3. Adaptive Forward Lighting (AFL) – halogen

Optional at extra cost on Club and Design, Adaptive Forward Lighting is a sophisticated new lighting system that allows you to see around corners! Meriva is one of the first cars in its class to offer such technology. *Autocar* magazine describes it as a 'must-have' feature. There are two main functions:

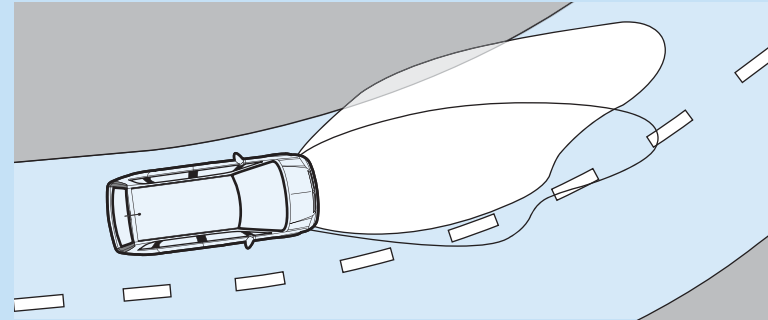

#### Curving light

Speed-dependent, the system is activated by movements of the steering wheel and allows the headlight beam to move up to 15 degrees left or right of the straight ahead position. This ensures that the main headlight beams are always aimed in the direction you're about to go – and not necessarily the direction the front of the car is already pointing in!

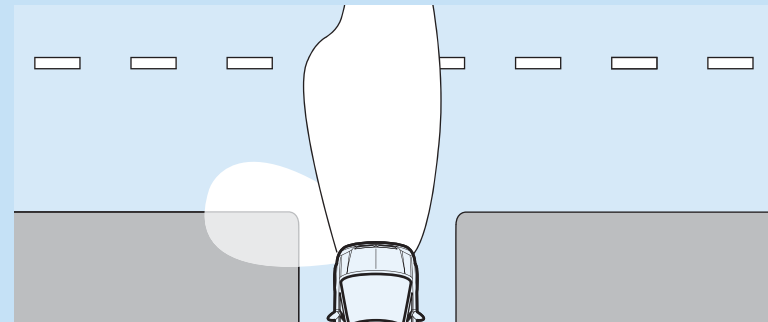

#### Cornering light

Employs an additional bulb and reflector which projects a beam of light approximately 90° to the direction of travel. This 'wide angle' effect provides enhanced illumination of side roads and junctions. The system is speed dependent.

Exterior dimensions millimetres (inches)

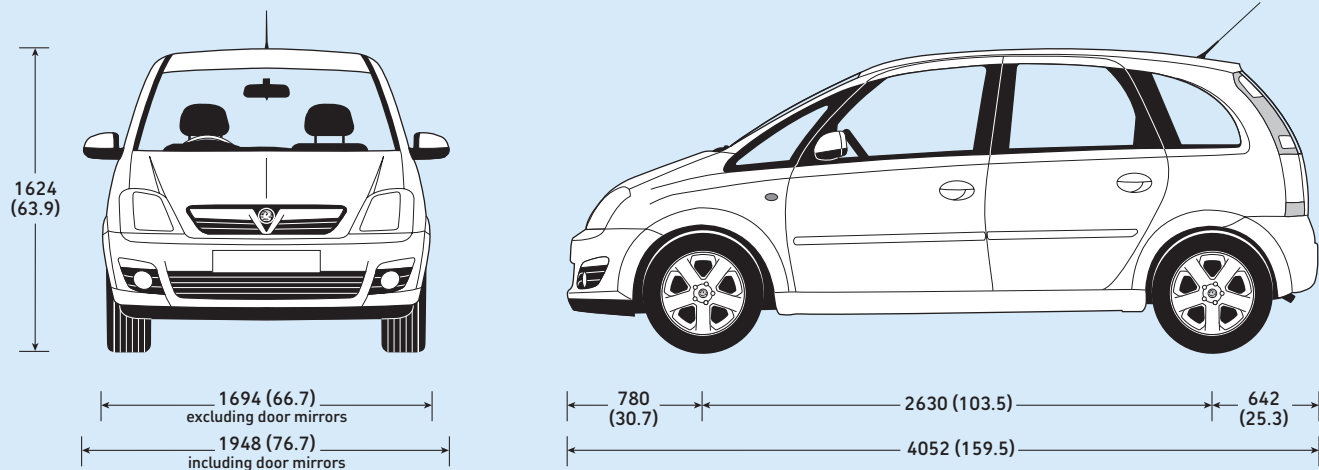

Luggage capacities (VDA method)

	litres	cu.ft
<b>Two rear seats configuration</b>		
Rear seats most rearward (29° reclined)	330	11.6
Rear seats most forward (17° reclined)	560	19.8
<b>Three rear seats configuration</b>		
Rear seats up (under luggage compartment cover)	350	12.4
Rear seats folded flat (to glass line)	890	31.4
Rear seats folded flat (to roof)	1410	49.8

Loadspace dimensions

	mm	inches
Maximum load length with fold-flat front passenger's seat	2400	94.5
Maximum load length behind front seat	1568	61.7
Maximum load area width	1110	43.7
Maximum load area height	852	33.5
Maximum tailgate aperture width	1099	43.3
Maximum tailgate aperture height	832	32.8



## Seating configurations

**1** With all three rear seats in place the backrests of the outer seats can be reclined individually.

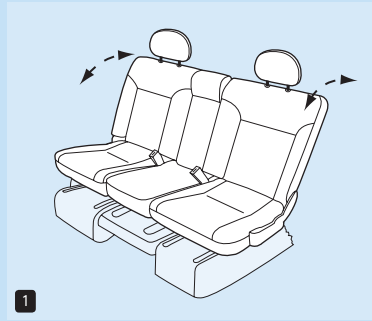

**2** Fold the centre rear seat down, and the base cantilevers downwards below the level of the outer rear seats.

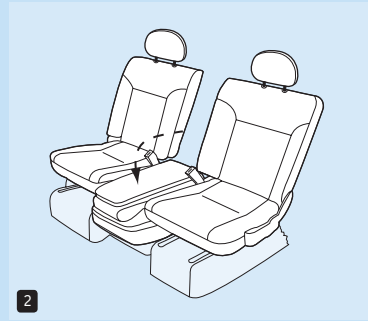

**3** The seats can now be slid inwards, providing generous shoulder room for rear seat passengers.

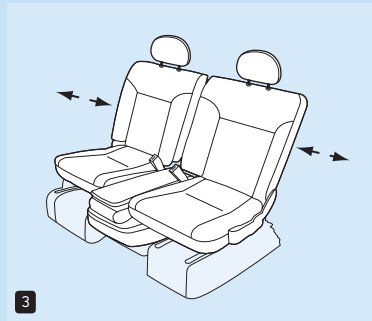

**4** Each rear seat can be individually slid backwards 70mm to provide extra legroom. And each backrest can be reclined a further six degrees (to 29 degrees) to give a truly relaxing travelling environment.

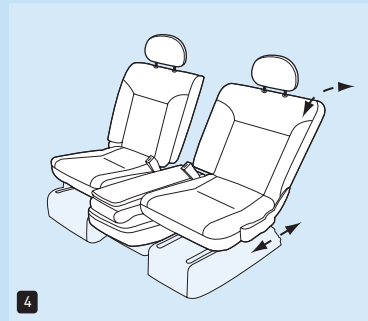

**5** Each part of the 40/20/40 rear seat back can be folded forward, giving a totally flat 1.5 metres long load area.

The optional fold-flat front passenger's seat allows loads of up to 2.4 metres in length to be carried.

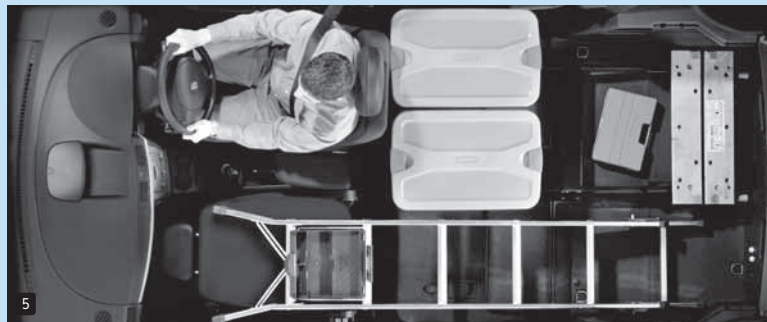

# Trust Vauxhall

## Protecting the environment

Vauxhall's commitment to the environment is demonstrated by our products' many environmental awards, won both through the use of more recycled materials and by becoming cleaner and more efficient. For information on Vauxhall's efforts to achieve an environmentally sustainable future, see [www.vauxhall.co.uk/recycling](http://www.vauxhall.co.uk/recycling)

## Fleet Customer Services

Our dedicated support services for fleet managers includes factory demonstrators, a three-day test drive programme and information on whole life costs, company car taxation and finance. For further information please call **0870 010 0651**.

## Buying your car

GMAC offers one of the most comprehensive and competitive ranges of financing plans in the UK. Contact your local Vauxhall retailer for details or call the GMAC customer service centre on **0845 712 3444**.

## Sureguard protection

Sureguard Assistance offers the benefits of Vauxhall Assistance for three years from first registration, while Sureguard Warranty also provides a parts and labour warranty for high-mileage or long-term owners. For details contact your local Vauxhall retailer or call **0870 752 7020**.

## Specialist Mobility advice

Motability accredited Vauxhall retailers can provide special mobility help and advice. Blue badge holders are entitled to very favourable discounts on new vehicles. Contact your local Motability accredited Vauxhall retailer or **Freefone 0800 731 5267**.

## Servicing and maintenance

The best way to maximise the performance and reliability of your Vauxhall is to have all routine servicing and maintenance carried out at one of around 400 Vauxhall retailers. To find your nearest retailer call **0845 600 1500**.

## In the event of an accident...

Vauxhall Accident Support helps keep you mobile following an accident. Benefits include scene-of-accident advice, message service, assistance with claims and vehicle recovery. For further details call **0800 010 304**.

## Vauxhall Insurance

Available for new and used Vauxhalls, a Vauxhall Insurance policy offers a unique package designed specifically for Vauxhall drivers. For a highly competitive quotation, call **0870 024 0240** or visit our website at [www.vauxhall.co.uk](http://www.vauxhall.co.uk)

## For more information...

For a brochure on any Vauxhall model (up to a maximum of three per caller) or location of your nearest Vauxhall retailer please Lo-call 0845 600 1500.

Alternatively, details can be found on our website at [www.vauxhall.co.uk](http://www.vauxhall.co.uk)



- Save up to **£2000\*** on a new Vauxhall with The GM Card
- 100 Rebate Points worth **£100** when you use The GM Card for the first time
- Rebate Point saving is on top of any discount or offer negotiated with the Retailer
- Earn 3 Rebate Points (**£3**) for every **£100** you spend

**Typical 14.9% APR variable**

To apply call **0845 746 2777** or visit [www.gmcard.co.uk](http://www.gmcard.co.uk).



When you have finished with this brochure please recycle it

The GM Platinum Card is issued by HFC Bank Limited and is available to persons aged 18 years or over and resident in the UK (or 21 and over in the Channel Islands) and is subject to status and conditions. Written quotations are available upon request from The GM Platinum Card, PO Box 3615, Birmingham B3 2RJ. The typical APR quoted is the rate for new customers. \*Rebate Points are earned on purchases using The GM Platinum Card. Rebate Points are not earned on Balance Transfers or Cash Advances. You earn money off a new Vauxhall/Saab by accumulating Rebate Points under the Rebate Points Programme. Vauxhall Motors Ltd is solely responsible for the operation of the Rebate Points Programme, which is subject to the Rebate Points Programme Rules. You can redeem up to 2500 Rebate Points subject to the Model Line Maximum which will vary in amount in relation to different Vauxhall/Saab vehicle model lines and unlimited Partner Points. Rebate Points and unlimited Partner Points are redeemable as discounts on a new Vauxhall/Saab vehicle and must be redeemed four years from the issue date. Rebate Points may not be redeemed by Motability Contract Hire customers. The GM Card is a trading name and style of both HFC Bank Limited and Vauxhall Motors Ltd. HFC Bank registered in England No. 1117305. Registered Office: North Street, Winkfield, Windsor, Berkshire SL4 4TD is authorised and regulated by the Financial Services Authority. **Member HSBC Group**. HFC Bank Limited is not a member of the same group of companies as Vauxhall Motors Ltd, Saab GB Limited or GMAC (UK) plc. Vauxhall Motors Ltd, Registered Office: Griffin House, Osborne Road, Luton, Bedfordshire LU1 3YT. Registered in England number 135767. - CN6/0987.

Every effort has been made to ensure that the contents of this publication were accurate and up-to-date at the time of going to press (January 2008). Vauxhall vehicles are equipped with components manufactured by various General Motors operating units and outside suppliers. The Company reserves the right to alter specifications and withdraw products from sale without notice. Any such alterations will be notified to Vauxhall retailers at the earliest opportunity, please consult your local retailer for the latest information. The specifications detailed within this brochure are not necessarily applicable to alternative models such as Special Editions. Details of any such models will be contained in specific literature or found on the Vauxhall website. Please note that Vauxhall retailers are not the agents of Vauxhall Motors Limited and are not authorised to bind the Company by any specific or implied undertaking or representation. It is advisable to ensure that your motor insurance policy provides adequate cover for additional fitted options and accessories. As part of Vauxhall's policy of environmental care, this brochure is printed on paper manufactured using Elemental Chlorine Free pulps from specially farmed, sustainable timber resources. All rights reserved. No part of this publication may be reproduced in any form or by any means, without the prior written permission of Vauxhall Motors Limited.

