

ZAFIRA TOURER

Range Highlights



Proud Sponsor of Home Nations Football







GET MORE OUT OF LIFE

Want more out of life? Then check out the all-new Zafira Tourer from Vauxhall. Available Spring 2012, the Zafira Tourer combines the dramatic looks and personality of a premium MPV with the versatility of a seven-seat people carrier – with leisure storage and luggage space to spare. The Tourer's terrific to drive. Supremely comfortable. And full of innovative features. So take a look at the stylish and flexible new Zafira Tourer. It's perfect for that active family lifestyle.

To find out how Zafira Tourer can help you get more out of life register now at: www.vauxhall.co.uk/zafiratourer

The vehicles illustrated within this brochure may not necessarily represent the correct final UK specification and not all the features described are available on every model.

THE POWER OF SELF EXPRESSION

If you thought all people carriers drove the same think again. With bespoke steering and suspension settings specifically tuned to the tough demands of UK roads and a Watt's link rear set-up for a smoother, more stable ride, the Zafira Tourer combines exemplary grip with serious agility – no matter how many passengers are on board.

Optional FlexRide with Continuous Damping Control lets you change the whole driving dynamic at the mere touch of a button. In 'Sport' mode, FlexRide sharpens the dampers and hones the steering and throttle response. In 'Tour' mode, it selects the best settings for gentler, long-distance cruising. The result: a driving experience to suit your every mood.





WELCOME TO THE CONTROL CENTRE

The best cars are designed around the driver. Slip behind the wheel of the new Zafira Tourer and you'll have the immediate impression that everything's been taken care of. Strikingly styled and comfortably trimmed with premium materials throughout, the Tourer provides conclusive proof that while we wholeheartedly support an active family's needs, we always have the driver's interests firmly in mind.

Thanks to the super-slim A-pillar design, the Zafira Tourer's visibility is outstanding – particularly with the impressive panoramic windscreen feature. The cabin's well-organised, thanks to the customisable FlexRail® centre console storage system. And everything falls readily to hand. In short: the Zafira Tourer leaves the driver comfortably in control – and passengers safely provided for.





Advanced driver assistance systems.

Underlining its position at the cutting edge of advanced in-car technology, The Zafira Tourer can be equipped with a range of sophisticated active safety systems. Options include Adaptive Cruise Control with Following Distance Indicator and Forward Collision Alert (complete with Automatic Brake Intervention) plus Lane Departure Warning and Traffic Sign Recognition. Drivers can also specify Advanced Parking Assistant with Side Blind Spot Alert for easier parking and safer lane changing.

Other options include the latest generation Adaptive Forward Lighting system and an advanced Satellite Navigation/CD player featuring MP3 format, DAB digital radio and an SD card-based memory function.

CLIMB IN CHILL OUT

Don't think of it as a travelling compartment. Think of it as a comfort zone. With Vauxhall's innovative Lounge Seating system, rear passengers have never felt more relaxed. The system converts in seconds from three individual second row seats that slide rearward and inward to create two welcoming, 'captain' style chairs, while the centre seat converts to an armrest, providing added comfort.

A clever rethinking of Vauxhall's legendary Flex7[®] seating system adds to the travelling experience. That means greater fore and aft adjustment. More reclining positions. And easy-entry third row seats. Plus a completely flat load floor once the rear seats have been folded.





1. Flat-folding seats. Loads come in all shapes and sizes, and so does the luggage area in the Zafira Tourer. Each individual rear passenger seat folds totally flat so you can carry passengers and bulky loads at one and the same time.

2. Extra large load space. Switch from limousine-like comfort to all-purpose carrying ability in just a matter of seconds – and transport that new item of furniture, DIY kit or leisure equipment with ease. Rear seats folded flat, the Zafira Tourer boasts a useful 1,860 litres of luggage space.





PARK AND RIDE ZAFIRA-STYLE

Looking for the ideal partner for your sporting or leisure activity? The Zafira Tourer carries it off – in style. Inside, the Tourer’s load carrying potential is exceptional with functional storage features and acres of space for all your kit. Outside, the optional FlexFix® carrier – fully integrated into the rear bumper – makes light work of transporting a couple of bikes. Need to carry an extra set of wheels or two? Simply attach the optional accessory FlexFix® extension and hey presto – the ideal platform for that impromptu cycling expedition, with space for four bikes.

➤ THE ULTIMATE CHOICE LIST

Dynamic, stylish and supremely versatile, Zafira Tourer is as individual as you are. Spend time choosing the model that's best suited to your personality and discover how Zafira Tourer can help you get more out of life.

Every new Zafira Tourer model is generously equipped. That much is a given. But rise up through the range and you'll discover more comfort features, additional sporty accents and a host of high-tech features to enjoy. In short – a model to suit your exact needs. Your retailer will be glad to talk through the choices available.



It's obvious Zafira Tourer drivers are individuals. And clear that the choice of models on offer doesn't disappoint. You can select from five separate trim levels: ES, Exclusiv, SRi, SE, and Elite – each providing its own, unique take on the distinctive Zafira Tourer character. Here's just a selection of the key features available.

ES	EXCLUSIV	SRi	SE	ELITE
<p>Feature highlights include:</p> <ul style="list-style-type: none"> • Electronic Stability Programme (ESP) • Six airbags • Air conditioning • CD/MP3 CD player with stereo radio • Aux-in socket • DAB digital radio • Cruise control • Steering wheel mounted audio controls • Remote control central deadlocking • Electrically operated front windows • Electrically adjustable/heated door mirrors • Luggage compartment cover • Black roof rails 	<p>Additional features over and above ES models:</p> <ul style="list-style-type: none"> • 17-inch structure wheels • Front fog lights • Front and rear parking distance sensors • USB connectivity • Electric rear windows • Multi-function trip computer • Front centre armrest • Ambient lighting in roof • Front passenger's underseat storage facility 	<p>Additional features over and above Exclusiv models:</p> <ul style="list-style-type: none"> • 18-inch alloy wheels • Sports chassis • Rear spoiler • Sports seats • Dark-tinted rear glass • Sports pedals • Three-spoke leather-covered steering wheel • Remote control security alarm system • Silver-effect roof rails 	<p>Additional features over and above Exclusiv models:</p> <ul style="list-style-type: none"> • 17-inch alloy wheels • Lounge seating • Electronic Climate Control (ECC) • Three-spoke leather-covered steering wheel • Rain-sensitive windscreen wipers • Dark-tinted rear glass • FlexRail® centre console system • Ambient lighting in centre console and front doors • Remote control security alarm system • Chrome lower window surround • Electric parking brake • Silver-effect roof rails 	<p>Additional features over and above SE models:</p> <ul style="list-style-type: none"> • 18-inch alloy wheels • Panoramic windscreen • Panoramic sunroof • Perforated leather seat facings • Ergonomic sports front seats with driver's extendable seat cushion • Driver's seat with tilt and four-way electric lumbar adjustment • Heated front seats <p><small>Please note: Elite models do not feature roof rails.</small></p>

➤ A PURER DRIVING DYNAMIC

Capable and above all great to drive, the Zafira Tourer matches genuine environmental credibility with serious driver appeal. A range of powerful yet economical and tax-efficient engines underlines its dynamic potential.

Zafira Tourer drivers can select from seven powerful yet efficient units. A highly flexible 140PS 1.8 litre petrol unit. Free-revving 140PS 1.4 litre turbo petrol engines, including a special low emissions version. Plus fuel efficient 2.0 litre turbo diesel engines, producing 110PS, 130PS and 165PS respectively. The 130PS unit can be specified with Vauxhall's market-leading ecoFLEX technology for outstandingly low emissions and excellent fuel economy – indeed, the unit is especially clean running, generating just 119g of CO₂ per kilometre.

In addition, all engines comply with the rigorous Euro 5 emissions standard. In some cases drivers can choose between manual and automatic options. The Zafira Tourer also features Vauxhall's cutting edge Start/Stop fuel saving and emissions reduction technology. Available with the 1.4 litre petrol unit alongside the 2.0 litre 130PS ecoFLEX and 165PS turbo diesels, this innovative system switches the engine off when you stop at the lights or in traffic, then restarts it automatically once the clutch is depressed.

ENGINES							
	Fuel economy mpg (litres/100km)			CO ₂ emissions (g/km)	VED (2011/12)*		Benefit in kind tax band** (2011/12 tax year)
	Urban driving	Extra-urban driving	Combined figure		First year	Standard	
Petrol							
1.8i 16v VVT (140PS)	29.1 (9.7)	48.7 (5.8)	39.2 (7.2)	169	£265	£190	23%
1.4i 16v VVT Turbo (140PS)	32.1 (8.8)	51.4 (5.5)	42.2 (6.7)	158	£165	£165	21%
1.4i 16v VVT Turbo (140PS) Start/Stop	34.9 (8.1)	53.3 (5.3)	44.8 (6.3)	148	£130	£130	19%
Diesel							
2.0CDTi 16v (110PS)	44.1 (6.4)	62.8 (4.5)	54.3 (5.2)	137	£115	£115	20%
2.0CDTi 16v (130PS)	44.1 (6.4)	62.8 (4.5)	54.3 (5.2)	137	£115	£115	20%
2.0CDTi 16v (130PS) ecoFLEX Start/Stop	53.3 (5.3)	70.6 (4.0)	62.8 (4.5)	119	£0	£30	13%
2.0CDTi 16v (165PS) Start/Stop	45.6 (6.2)	61.4 (4.6)	54.3 (5.2)	137	£115	£115	20%

*Correct at time of publication (February 2012). **Taxation information for guidance only. Please take professional advice on your own tax position. Please refer to the Price Guide for further details.

WHEELS AND TYRES

Nothing turns heads like an impressive set of wheels. The Zafira Tourer has it covered, big time, with sizes up to 19-inch available.

STANDARD WHEELS

ES



17-inch steel wheels with 225/50 R 17 tyres.*

EXCLUSIV



17-inch 5-spoke structure wheels with 225/50 R 17 tyres.

SRI



18-inch 5-twinspoke alloy wheels with 235/45 R 18 tyres.

ELITE



18-inch 10-spoke alloy wheels with 235/45 R 18 tyres.

SE



17-inch 10-spoke alloy wheels with 225/50 R 17 tyres.

OPTIONAL WHEELS**

EXCLUSIV



17-inch 10-spoke alloy wheels with 225/50 R 17 tyres.

SRI



19-inch 5-spoke bi-colour alloy wheels with 235/40 R 19 tyres.

ELITE



19-inch 5-spoke alloy wheels with 235/40 R 19 tyres.

SE



18-inch 10-spoke alloy wheels with 235/45 R 18 tyres.†

Please note: A space-saver spare wheel is available at extra cost in lieu of the emergency tyre inflation kit.

*1.8i 16v VVT (140PS) models feature 16-inch steel wheels with 215/60 R 16 tyres. **Optional at extra cost. †Not available on 2.0i CDTi 16v (130PS) ecoFLEX model. Please note: Optional wheels can result in higher fuel consumption and CO₂ emissions. Please refer to page 22 for more information.

EXTERIOR COLOURS

A car as accomplished as the Zafira Tourer demands the perfect finish. Take your pick from a range of striking colours.

SOLID

BRILLIANT*

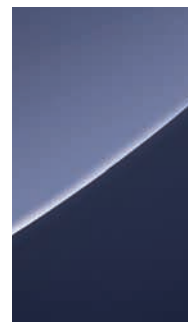

Royal Blue



Power Red
(two-coat)



Olympic White

TWO-COAT METALLIC*



Sovereign Silver



Silver Lake



Silky Shadow

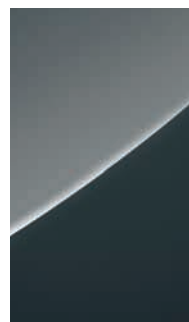

Technical Grey

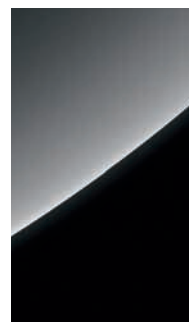

Carbon Flash

TWO-COAT PEARLESCENT*



Macadamia

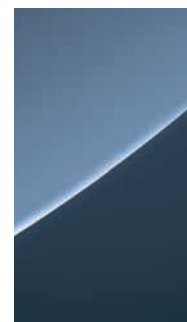

Waterworld

*Optional at extra cost.

Due to the limitations of the printing process, the colours reproduced may vary slightly from the actual paint colour and trim material. As a result, they should be used as a guide only. Your Vauxhall retailer has a comprehensive display of our paint samples and trim swatches.

▶ INTERIOR TRIMS

Smart colour matches. Premium materials.
A winning combination that's every bit as
individual as the car itself.

CATANIA/ATLANTIS TRIM

ES



Catania seat inserts in Jet Black.

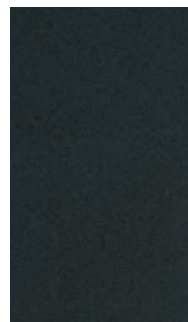

Atlantis bolsters in Jet Black.

MANDO/ATLANTIS TRIM

EXCLUSIV



Mando seat inserts in Jet Black.



Atlantis bolsters in Jet Black.

LACE/ATLANTIS TRIM

SRI

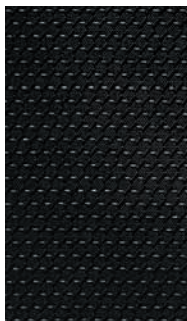

Lace seat inserts in Jet Black.

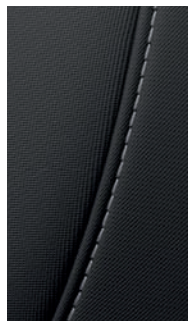

Atlantis bolsters in Jet Black.

SALERNO/MORROCANA

SE STANDARD TRIM

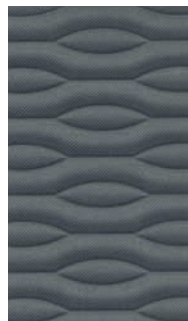

Salerno seat inserts in Dark Galvanised.

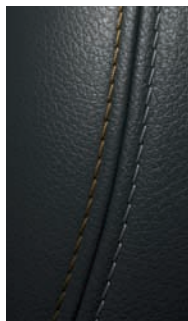

Morrocana bolsters in Jet Black.

SALERNO/MORROCANA

SE OPTIONAL TRIM



Salerno seat inserts in Choccachino.



Morrocana bolsters in Cocoa.

LEATHER MONDIAL

ELITE

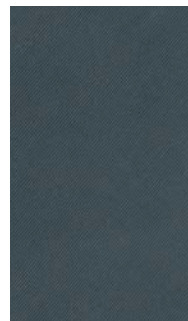

Leather seat inserts in Dark Galvanised.

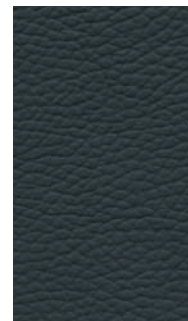

Leather bolsters in Jet Black.

Safety

Standard features

• Driver's airbag • Front passenger's airbag • Front seat side-impact airbags • Full-size curtain airbags • Deactivation switch for front passenger's front and side-impact airbags – Ensures front passenger airbags do not inflate when a child seat is fitted to the front passenger's seat • Active-safety front seat head restraints • Height-adjustable front and outer rear seat head restraints • Five lap and diagonal inertia-reel seatbelts (height-adjustable front) • Front body-lock diagonal seatbelt pretensioner system • Drivers and front passenger's lap belt pretensioner system • Front seatbelt force limiters • Anti-submarining ramps in front seats • ISOFIX child seat restraint system for outer rear seats incorporating top tether (does not include child seat) – Secures specially designed ISOFIX child safety seats to the vehicle itself, virtually eliminating the dangers that can result from improper installation • Electronic Stability Programme-plus (ESP-plus) • Anti-lock Braking System (ABS) • Electronic Brakeforce Distribution (EBD) • Cornering Brake Control (CBC) • Hydraulic Brake Fade Assist • Emergency Brake Assist • Straight Line Stability control • Traction control • Adaptive brake lights • Energy-absorbing steering column • Pedal release system • Laminated windscreen • Side-impact protection beams • Reinforced passenger safety cell • Deformation zones front and rear • Burst-proof door locks and anti-jam door design • Multi-pivot bonnet hinges • Collapsible windscreen wiper system • Low density foam near front bumper crossmember • Plastic lower front bumper stiffener

Additional feature

Tyre pressure monitoring system

ES	Exclusiv	SRI	SE	Elite
	○	○	○	○

Security

Standard features • Driver's internal central locking switch • 'Key left in ignition' audible warning • Electronic theft protection for audio equipment • Remote control central deadlocking (doors, tailgate, fuel filler flap) • Electronic engine deadlock immobiliser • Visible Vehicle Identification Number (VIN) plate • Freewheeling door locks • Locking wheel nuts for alloy wheels (where fitted)

Additional feature

Remote control ultrasonic security alarm system

ES	Exclusiv	SRI	SE	Elite
	○	●	●	●

Facia, instruments and controls

Standard features • Cruise control • Rev counter • Multi-function display showing time, date, audio information and outside air temperature • Digital clock with automatic RDS time adjustment • Steering column adjustable for reach and rake • Electronic odometer and trip odometer • Instrument panel light dimmer • Parking brake-on/low brake fluid level and low fuel level warning lights • Service interval monitor • Seatbelt unfastened warning light

Additional features

Electric parking brake incorporating Hill Start Assist (HSA)

Three-spoke chrome-bezelled steering wheel

Three-spoke chrome-bezelled leather-covered steering wheel

Leather-covered gear knob (manual models only)

Black instruments with chrome edging

Translucent instruments with chrome edging

Multi-function trip computer (instantaneous fuel consumption, average fuel consumption, range remaining, two trip odometers running concurrently, instantaneous speed, average speed)

Sports pedals

ES	Exclusiv	SRI	SE	Elite
			●	●
●	●			
		●	●	●
		●	●	●
●				
	●	●	●	●
		●		

Interior lighting

Standard features • Fade up/fade down courtesy lights operated by door switches • Third-row passenger compartment reading lights and front map reading lights integral with front courtesy light • Illuminated glovebox and luggage area

Additional feature	ES	Exclusiv	SRi	SE	Elite
Ambient lighting in roof		●	●	●	
Ambient lighting in centre console surround and front doors				●	●

Seating and upholstery

Standard features • Flex7® seating system • Driver's seat with height, reach and recline adjustment • Front passengers seat with reach and recline adjustment • 35/30/35 split-folding second-row seats • Second-row seats with sliding function plus fold-flat facility • Two individual fold-flat third-row seats • Carpeted passenger compartment, load area and rear seat backs

Additional features	ES	Exclusiv	SRi	SE	Elite
Catania cloth seat trim	●				
Mando cloth seat trim		●			
Lace cloth seat trim			●		
Salerno cloth seat trim with Morrocana-trimmed side bolsters				●	
Leather seat facings (includes heated front seats with variable temperature settings)					●
Ergonomic sports front seats with driver's extendable seat cushion, four way electrical lumbar adjustment and seat tilt adjustment			□	○ ¹	●
Three individual second-row seats with the ability to convert into two 'captain' seats with armrests				●	●
Sports front seats			●		
Storage pockets on front seat backs		●	●	●	●
Driver's under seat storage facility				●	●
Front passenger's underseat storage facility		●	●	●	●
Front centre armrest		●	●	●	●

Additional interior features

Standard features • 12-volt auxiliary power socket within front and rear centre console and luggage compartment • Twin sunvisors incorporating illuminated driver's and front passenger's vanity mirrors with covers • Chrome-effect internal door handles • Storage box on driver's side lower fascia • Front door pockets • Third row central storage facility with two cup holders • Fully carpeted luggage area • Load restraint lashing eyes • Luggage compartment cover

Additional features	ES	Exclusiv	SRi	SE	Elite
Driver's sunglasses holder		●	●	●	
Central storage facility with three cup holders	●				
Central covered storage facility with two cup holders		●	●		
FlexRail® centre console system featuring aluminium rails and sliding tray/cup holder				●	●
Electro-chromatic anti-dazzle rear-view mirror			□	●	●
Vertical load-restraining net	○	○	○	○	○
FlexCover interior protection liner ²	○	○	○	○	○
Rear side window sunblinds		○	○	○	○

● = Standard equipment. ○ = Optional at extra cost. □ = Only available as part of an extra-cost option pack (see page 21 for details). 1 = Not available with optional Choccachino seat trim and changes standard trim to Lace cloth. 2 = Not available in conjunction with 1.8i 16v VVT (140PS) models.

Heating and ventilation

Standard features • Air conditioning with air recirculation • Air blend heater with six-speed fan • Side window demist vents and adjustable face-level air vents • Interior pollen filter • Rear passenger compartment heating outlets

Additional feature	ES	Exclusiv	SRI	SE	Elite
Dual-zone Electronic Climate Control (ECC) incorporating air conditioning with humidity sensor			○	●	●

Exterior styling and protection

Standard features • Body-colour door mirrors • Chrome-effect upper grille surround • Black trim on door pillars

Additional features	ES	Exclusiv	SRI	SE	Elite
Body colour door handles	●	●	●		
Chrome-effect door handles				●	●
Chrome-effect front door sill covers and side window mouldings				●	●

Exterior lighting

Standard features • Lights-on audible warning • LED centre brake light • Reversing light, rear fog light, hazard warning lights, side repeat indicators • Ellipsoid headlights • Electric headlight beam levelling • Dark-style headlights • Daytime running lights • Dark-style tail lights

Additional features	ES	Exclusiv	SRI	SE	Elite
Intelligent Adaptive Forward Lighting (AFL) incorporating dark-style bi-xenon headlights with dynamic beam levelling. LED daytime running lights and high-pressure headlight washers			□	□	□
Front fog lights		●	●	●	●
Automatic lighting control with tunnel detection and digital high beam assist			□	●	●
LED rear lights		○	○	○	○

Exterior and convenience features

Standard features • Electrically operated front windows with safety autoreverse and one-touch facility • Twin electrically adjustable/heated door mirrors (wide angle on driver's side) • Manually foldable door mirrors • Tinted glass • Windscreen wipers with variable intermittent facility and flick-wipe • Twin-jet windscreen washer nozzles • Heated rear window with automatic timed cut-off • Intermittent rear window wash/wipe • Gas-assisted tailgate struts • Folding key

Additional features	ES	Exclusiv	SRI	SE	Elite
Hill Start Assist (HSA)				●	●
Panoramic windscreen and panoramic sunroof with electrically operated interior sunblind ³			○ ⁴	○ ⁴	●
Electrically foldable door mirrors		○	○	○	○
Electrically operated rear windows		●	●	●	●
Rain-sensitive windscreen wipers			□	●	●
Dark-tinted rear windows			●	●	●
Front and rear parking distance sensors	○	●	●	●	●
Black roof rails	●	●			
Silver-effect roof rails			●	●	
Flex-Fix [®] integrated carrier system (includes two-bicycle carrier attachments) ⁵			○	○ ⁶	○

● = Standard equipment. ○ = Optional at extra cost. □ = Only available as part of an extra-cost option pack (see page 21 for details). ³ = Only available in conjunction with Electronic Climate Control (ECC). ⁴ = Deletes silver-effect roof rails. ⁵ = Not available in conjunction with space-saver spare wheel, Towing Pack or VXR Styling Pack. ⁶ = Not available on 2.0CDTi 16v (130PS) ecoFLEX Start/Stop models.

Mechanical

Standard features • Lightweight MacPherson strut front suspension • Semi-independent rear suspension with Watt's link and gas-pressure dampers • Power-assisted steering
• Six-speed manual gearbox

Additional features

	ES	Exclusiv	SRi	SE	Elite
FlexRide adaptive chassis control system with Continuous Damping Control (CDC)			○	○ ⁶	○
Lowered and uprated sports suspension			●		

Option packs

	ES	Exclusiv	SRi	SE	Elite
Seat Comfort Pack One • Driver's seat with six-way manual adjustment and four-way electrical lumbar adjustment	○	○	●	○	
Seat Comfort Pack Two ² • Driver's and front passenger's seat with six-way manual adjustment and four-way electrical lumbar adjustment	○	○		○ ⁷	
Sight and Light Pack • Automatic lighting control with tunnel detection • Rain-sensitive windscreen wipers • Electro-chromatic anti-dazzle rear-view mirror • Digital high beam assist			○	●	●
Leather Pack • Leather seat facings • Electrically heated front seats • Driver's ergonomic sports front seat • Front passenger's extendable seat cushion			○		●
Premium Forward Lighting Pack • Intelligent Adaptive Forward Lighting (AFL) • Dark-style bi-xenon headlights with dynamic beam levelling • LED daytime running lights • High-pressure headlight washers			○ ⁸	○	○
Front Camera System ⁹ • Solar Protect windscreen • Adaptive Cruise Control • Following Distance Indicator • Forward Collision Alert • Lane Departure Warning • Traffic Sign Recognition				○	○
Park and Go Technology Pack • Satellite navigation (Navi 600) • Rear view camera • Advanced Parking Assist (APA) • Side Blind Spot Alert • Electrically foldable door mirrors			○	○	○
VXR Styling Pack ¹⁰ • Body-colour front lower spoiler, side sills, rear lower skirt and rear roof spoiler		○	○	○	○
Towing Pack ² • Detachable tow bar • Trailer stability programme	○	○	○	○	○
FlexOrganiser Pack [®] • FlexOrganiser [®] rails • Restraint net with 2 bars • Small luggage restraint net • Adaptors	○	○	○	○	○

Audio, communication and navigation**Features**

	ES	Exclusiv	SRi	SE	Elite
CD/MP3 CD player/stereo radio (CD 400) • CD/MP3 CD player • AM/FM stereo radio with 36 station presets • Aux-in socket • RDS with Traffic Programme • Graphic display • 20 watts per channel output • 7 speakers • Roof mounted flexible aerial	●	●	●	●	●
Satellite navigation/CD/MP3 CD player/stereo radio (Navi 600) • Satellite navigation system • Street level mapping for UK and Ireland • CD/MP3 CD player • SD card slot and aux-in socket • AM/FM stereo radio with 36 station presets • RDS with Traffic Programme • Remote colour monitor • 20 watts per channel output • 7 speakers • Shark fin/integrated aerial		○	○	○	○
Satellite navigation/CD/MP3 CD player/stereo radio (Navi 900) • Satellite navigation system • Street level mapping for Europe • Major route mapping for more than 30 European countries • CD/MP3 CD player • SD card slot and aux-in socket • AM/FM stereo radio with 36 station presets • RDS with Traffic Programme • Remote colour monitor • 20 watts per channel output • 7 speakers • Shark fin/integrated aerial		○	○	○	○
DAB digital radio with integrated aerial	●	●	●	●	●
USB connection with iPod control	○	●	●	●	●
Steering wheel mounted audio controls	●	●	●	●	●
Bluetooth [®] mobile phone system (does not include phone)	○	○	○	○	○
Embedded Bluetooth [®] mobile phone system (does not include phone)		○	○	○	○

2 = Not available in conjunction with 1.8i 16v VVT (140PS) models. 7 = Deletes driver's and front passenger's underseat storage facility. 8 = Only available in conjunction with Sight and Light Pack. 9 = Only available on 2.0CDTi 16v (165PS) manual and automatic models, and 1.4i 16v VVT Turbo manual models. 10 = Not available in conjunction with Flex-Fix[®] integrated carrier system, 1.8i 16v VVT (140PS), 1.4i 16v VVT Turbo Start/Stop, 2.0CDTi 16v (130PS) ecoFLEX Start/Stop models or Royal Blue and Silky Shadow exterior colours.

Engines

	1.8i 16v VVT (140PS) ECOTEC-4	1.4i 16v VVT Turbo (140PS) ECOTEC-4 with and without Start/Stop	2.0CDTi 16v (110PS) ECOTEC-4 Turbo diesel	2.0CDTi 16v (130PS) ECOTEC-4 Turbo diesel with and without Start/Stop	2.0CDTi 16v (165PS) ECOTEC-4 Turbo diesel with Start/Stop
Fuel type	Petrol	Petrol	Diesel	Diesel	Diesel
Capacity	1796cc	1364cc	1956cc	1956cc	1956cc
Maximum power	140PS (103kW) @ 6300rpm	140PS (103kW) @ 4900-6000rpm	110PS (81kW) @ 4000rpm	130PS (96kW) @ 4000rpm	165PS (121kW) @ 4000rpm
Maximum torque	175Nm (129 lb.ft.) @ 3800rpm	200Nm (147 lb.ft.) @ 1850-4900rpm	260Nm (192 lb.ft.) @ 1750-2500rpm	300Nm (221 lb.ft.) @ 1750-2500rpm	350Nm (258 lb.ft.) @ 1750-2500rpm
Configuration	4 cylinders, 4 valves per cylinder, double overhead camshafts				
Fuel/induction system	Naturally aspirated Variable Valve Timing (VVT). Multi-point sequential fuel injection	Water-cooled turbocharger with intercooler. Variable Valve Timing (VVT). Multi-point sequential fuel injection		Variable geometry turbocharger with intercooler. Common rail fuel injection. Diesel Particulate Filter	
Emission compliance	Euro 5				
Service interval	20,000 miles or 1 year (whichever occurs sooner)				
Benefit in kind company car taxation – 2011/12 tax year (Provisional data)					
Manual	23%	19%/21%*	20%	13%/20%*	20%
Automatic	-	23%	-	-	24%

* = Non Start/Stop models.

Performance, fuel economy, emissions and VED rates (Provisional data)

	Wheel size (inches)	Performance (manufacturer's figures)		Fuel economy mpg (litres/100km)			CO ₂ emissions g/km	VED [†]	
		Maximum speed (mph)	Acceleration 0-60mph (sec)	Urban driving	Extra- urban driving	Combined figure		First year rate	Standard rate
Manual									
1.8i 16v VVT (140PS)	16/17	121	10.9	29.1 (9.7)	48.7 (5.8)	39.2 (7.2)	169	£265	£190
1.4i 16v VVT Turbo (140PS)	17/18/19	124	9.9	32.1 (8.8)	51.4 (5.5)	42.2 (6.7)	158	£165	£165
1.4i 16v VVT Turbo (140PS) Start/Stop	17/18/19	126	9.9	34.9 (8.1)	53.3 (5.3)	44.8 (6.3)	148	£130	£130
2.0CDTi 16v (110PS)	17/18/19	114	11.5	44.1 (6.4)	62.8 (4.5)	54.3 (5.2)	137	£115	£115
2.0CDTi 16v (130PS) ecoFLEX Start/Stop	17/18	120	10.6	53.3 (5.3)	70.6 (4.0)	62.8 (4.5)	119	£0	£30
2.0CDTi 16v (130PS)	17/18/19	119	10.6	44.1 (6.4)	62.8 (4.5)	54.3 (5.2)	137	£115	£115
2.0CDTi 16v (165PS) Start/Stop	17/18/19	129	9.1	45.6 (6.2)	61.4 (4.6)	54.3 (5.2)	137	£115	£115
Automatic									
1.4i 16v VVT Turbo (140PS)	17/18/19	122	10.2	29.1 (9.7)	48.7 (5.8)	39.2 (7.2)	169	£265	£190
2.0CDTi 16v (165PS)	17/18/19	127	9.3	35.3 (8.0)	57.6 (4.9)	47.1 (6.0)	159	£165	£165

[†]VED = Vehicle Excise Duty. Correct at time of publication (October 2011).

Fuel consumption and CO₂ emission data complies with the relevant EU testing regulations used by vehicle manufacturers to enable comparisons between different models. **Important:** Please note fuel consumption can be affected by many factors including driving style, road and traffic conditions, vehicle mileage and standard of maintenance. In addition these results relate to the particular vehicle tested, inevitably there will be differences between individual vehicles of the same model.

Exterior dimensions millimetres (inches)

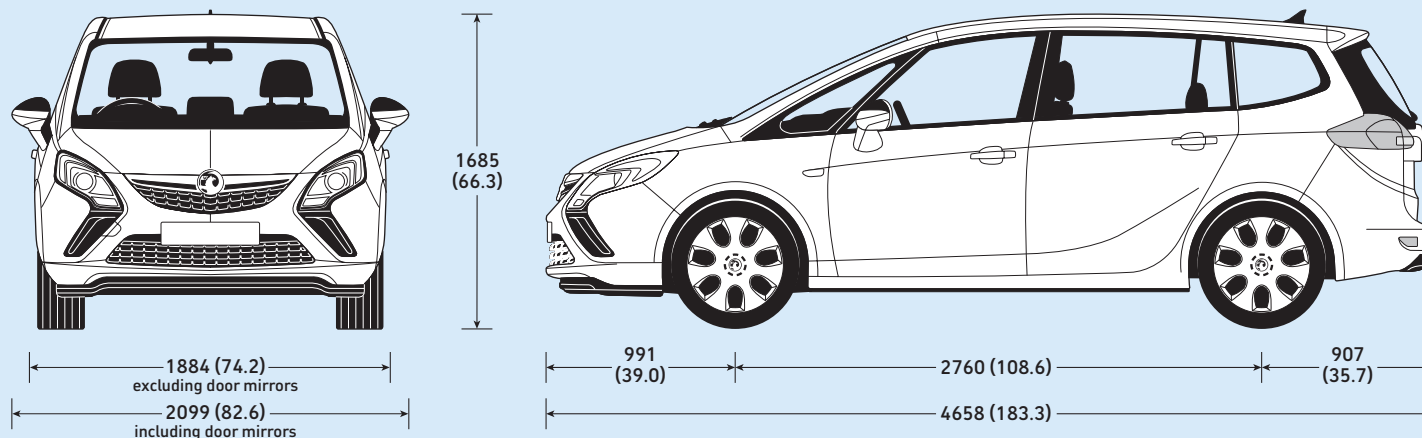

Luggage capacities (measured using the ECIE method)

	litres	cu.ft
Behind third-row, to glass line	152	5.4
Behind second-row, to glass line	710	25.1
Behind front seats, to roof	1860	65.6

Loadspace dimensions

	mm	inches
Maximum floor length – behind front seats, second-row and third-row seats folded	1832	72.1
Maximum floor length – behind second-row seat	1093	43.0
Width between wheel arches	1057	41.6
Tailgate aperture height	840	33.0
Tailgate aperture lower width	1050	41.3

Weights and towing data kg

	Gross vehicle weight	Max. towing weights Trailer with brakes (without brakes)
1.8i 16v VVT (140PS)	2150	1150 (750)
1.4i 16v VVT Turbo (140PS)	2310	1250 (750)
1.4i 16v VVT Turbo (140PS) Start/Stop	2320	1250 (750)
1.4i 16v VVT Turbo (140PS) automatic	2340	1250 (750)
2.0CDTi 16v (110PS)	2415	1300 (750)
2.0CDTi 16v (130PS) ecoFLEX Start/Stop	2340	1300 (750)
2.0CDTi 16v (130PS)	2410	1300 (750)
2.0CDTi 16v (165PS) Start/Stop	2430	1450 (750)
2.0CDTi 16v (165PS) automatic	2445	1400 (750)

Gross vehicle weight is the total permissible weight of the vehicle including passengers and their luggage. The **maximum roof rack loading** should not exceed 100kg. The **maximum towing weights** are based on the ability of the car, with two occupants of 75kg each, to restart on a 12% gradient, which is approximately 1 in 8.3, at sea level. At altitudes above 1500 metres, the engine output may drop with a corresponding reduction in towing capability. Any extra weight, such as luggage or additional passengers, should be deducted from the maximum towing weight. With a trailer fully loaded, **maximum noseweight** should not exceed 75kg. Always fit Vauxhall towing attachments and accessories available from your Vauxhall retailer. They are designed specifically for Vauxhall models and carry a 12-month guarantee.

Trust Vauxhall

Vauxhall Insurance

Available for new and used Vauxhalls, a Vauxhall Insurance policy offers a unique package designed specifically for Vauxhall drivers. For a highly competitive quotation, call **0844 463 2670**. Or just visit our website at www.vauxhall.co.uk

Fleet Customer Services

Our dedicated support services for fleet managers includes factory demonstrators, a three-day test drive programme and information on whole life costs, company car taxation and finance. For further information please call **0870 010 0651**.

Buying your car

GMAC offers one of the most comprehensive and competitive ranges of financing plans in the UK. Contact your local Vauxhall retailer for details or call the GMAC customer service centre on **0845 712 3444**.

Servicing and maintenance

The best way to maximise the performance and reliability of your Vauxhall is to have all routine servicing and maintenance carried out at one of around 400 Vauxhall retailers. To find your nearest retailer call **0845 600 1500**.

In the event of an accident...

Vauxhall Accident Support helps keep you mobile following an accident. Benefits include scene-of-accident advice, message service, assistance with claims and vehicle recovery. For further details call **0800 010 304**.

Proud Sponsor of Home Nations Football



For more information...

For a brochure on any Vauxhall model (up to a maximum of three per caller) or location of your nearest Vauxhall retailer please call **0845 600 1500**.

Alternatively, details can be found on our website at www.vauxhall.co.uk

Join us online:



Scan this QR code with your smartphone for more information. Don't forget to download a QR reader from your app store first.

Vauxhall Lifetime Warranty

We're so confident in Vauxhall quality and reliability that we are now able to offer a lifetime warranty. Available to the first owner of all new Vauxhall passenger cars, it's valid for the lifetime of the vehicle up to a maximum of 100,000 miles*. In addition, our warranty also includes Vauxhall Assistance for 12 months from first registration and six years body panel anti-perforation warranty. Full details of Vauxhall's warranties including terms, conditions and exclusions can be obtained through any authorised Vauxhall retailer or go to: www.vauxhall.co.uk/warranty

LIFETIME
WARRANTY 100,000 MILE



When you have finished with this brochure please recycle it

*Vauxhall Lifetime Warranty covers lifetime ownership of first car owner, 100,000 mile limit, annual check required. The warranty excludes wear and tear and serviceable items and the vehicle must be serviced in accordance with the manufacturer's servicing schedule to continue the lifetime warranty. Terms and conditions apply. Offer available to all Vauxhall passenger cars (this offer does not apply to car-derived vans) from 1st August 2010.

Every effort has been made to ensure that the contents of this publication were accurate and up-to-date at the time of publication (February 2012). Vauxhall vehicles are equipped with components manufactured by various General Motors operating units and outside suppliers. The Company reserves the right to alter specifications and withdraw products from sale without notice. Any such alterations will be notified to Vauxhall retailers at the earliest opportunity, please consult your local retailer for the latest information. The specifications detailed within this brochure are not necessarily applicable to alternative models such as Special Editions. Details of any such models will be contained in specific literature or found on the Vauxhall website. Please note that Vauxhall retailers are not the agents of General Motors UK Limited and are not authorised to bind the Company by any specific or implied undertaking or representation. It is advisable to ensure that your motor insurance policy provides adequate cover for additional fitted options and accessories. Please note accessories shown are for illustrative purposes only. As part of Vauxhall's policy of environmental care, this brochure is printed on paper manufactured using Elemental Chlorine Free pulps from specially farmed, sustainable timber resources. All rights reserved. No part of this publication may be reproduced in any form or by any means, without the prior written permission of General Motors UK Limited.



VAUXHALL